

# Gain energy insight and control with PowerLogic™

## PowerLogic ION8800

energy and power quality meter



# Features

## Easy installation

Rackmount design to DIN 43862 standard allows for easy retrofit into existing systems. Essailec connector with common measurement and energy pulsing pin-out greatly reduces installation costs.

## High accuracy measurements

IEC 62053-22 Class 0,2S compliant metering accuracy. One second loss calculation and error correction capabilities establish system losses and correct for measurement errors in real time.

## Power quality compliance monitoring

Measure compliance to the following international quality-of-supply standards:

- EN 50160, IEEE 1159, ITI (CBEMA), SARFI

Trust the quality of the results because compliance calculations are based on the following international measurement standards:

- IEC 61000-4-30 class A, IEC 61000-4-7, IEC 61000-4-15

## Power quality analysis

Digital fault-recording capabilities simultaneously capture voltage and current channels for sub-cycle disturbance transients as well as multi-cycle sags/dips, swells and outages.

## Transformer/line loss calculation functionality

Automatically measure, compensate and correct for transformer or line losses when meter is physically separated from billing point or change of ownership location.

## Complete communications: Fibre - Ethernet - Serial - Modem

Gateway functionality simplifies communications architecture and reduces leased line or connection costs. Concurrent, independent ports communicate with a variety of protocols such as ION, DNP 3.0, Modbus RTU, Modbus TCP, DLMS (IEC 62056), and IEC 60870-5-102\*.

## Multi-user, multi-level security

Control and customise access to sensitive data for up to 16 users. Password protection and anti-tamper seal protection enhance meter security.

## Extensive data logging

Non-volatile on-board logging of min/max values, energy and demand, maintenance data, alarms, and any measured parameters. Dial-out capability when memory is near full. Data push capability through SMTP (email).

## Patented ION™ technology

Provides a modular, flexible architecture that offers extensive user programmability. Uniquely addresses complex monitoring and control applications. Adapts to changing needs and new applications, thereby avoiding obsolescence.

Integrated network comprising corporate intranet, Internet, serial, dial-up or wireless connections

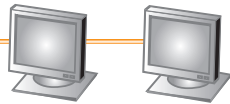

Financial management including accounting and billing

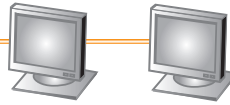

Facility and energy management

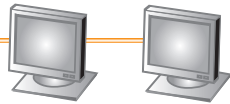

Operations management including engineering, planning and maintenance



Power generation, transmission and distribution



Service entrances and onsite generation



Power mitigation and main power distribution equipment

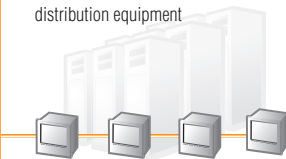

PDUs and data servers

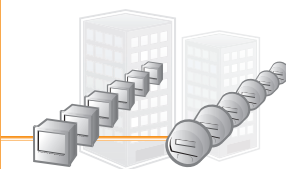

Tenants, departments or subcontractors

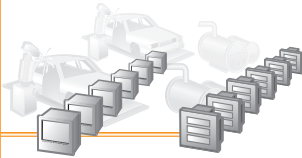

Processes, lines, machines or equipment

\* Contact factory for information.



## Intelligent transmission and distribution network meter

Providing high accuracy and compliance to the most stringent power quality measurement standards, the Schneider Electric PowerLogic ION8800 is the most advanced energy and power quality meter with the flexibility to change as your needs change.

The PowerLogic ION8800 is ideally suited to local and remote monitoring of generation, transmission and distribution inter-tie points in utility networks. The meter provides the information necessary to monitor power quality compliance, supply agreements and regulatory requirements and to perform network capacity planning and stability analysis.

Its impressive feature set boasts advanced power quality analysis features, such as waveform recording and transient detection, numerous communications options, web compatibility and control capabilities. Integrate with your existing wholesale settlement system, use ION Enterprise™ software, or share operations data with existing SCADA systems through multiple communication channels and protocols.

## Typical applications

For electric utilities

- Revenue metering and power quality
  - Install high-accuracy metering at all interchange points
  - Improve or verify metering accuracy at existing interchange points
  - Help customers manage costs using value-added billing data
  - Verify compliance with new power quality standards
  - Analyse and isolate the source of power quality problems
- Energy availability and reliability
  - Improve T&D network reliability
  - Enhance substation automation to reduce field service time
  - Maximise the use of existing infrastructure

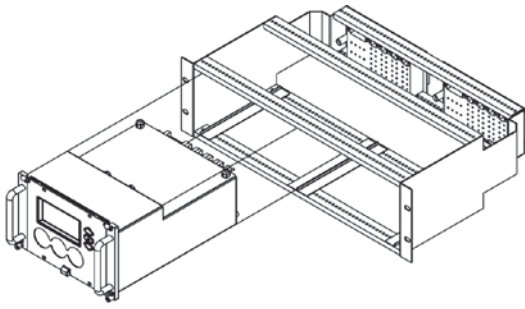

Mounting the ION8800 in a IEC/DIN 43862 rack

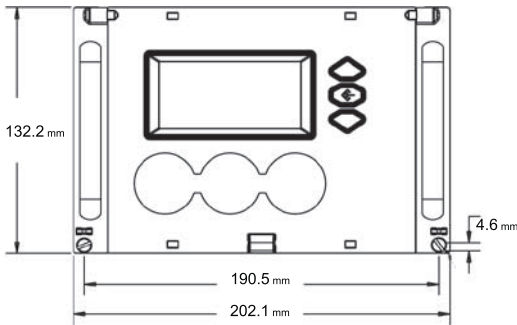

Meter dimension (front)

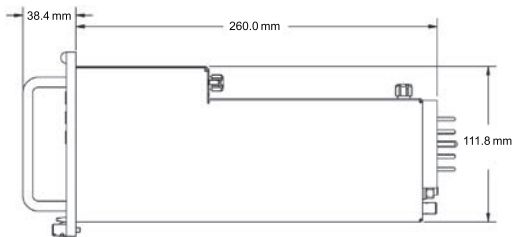

Meter dimension (side)

## Installation

### Mounting options

Easily installs into new or existing IEC/DIN 43862 racks, thereby reducing installation costs.

### Circuit and control power connections

Meter has 3 voltage inputs and 4 current inputs compatible with 4-wire Wye, 3-wire Wye, 3-wire Delta, and Single-phase systems. Direct connect inputs up to 288 V ac line-to-neutral or 500 V ac line-to-line or use voltage (potential) transformers for higher voltage systems. All models come standard with 5 A nominal current inputs; 1 A nominal current inputs are optional. The single phase power supply connections are located on the Essailec connector.

Input	Specifications
Voltage (U1, U2, U3, Uref)	Accuracy and rating range: 57 - 288 V ac L-N rms (99 - 500 V ac L-L rms); Fault capture: 1200 V peak (L-N); Overload: 1500 V ac rms continuous; Dielectric withstand: 3250 V ac rms @ 50 Hz for 60 s; Impedance: 5 MΩ/phase (phase - Uref/Ground); Rating: Measurement category III
Current: high-current option	Accuracy range: 0.05 A - 10 A autoranging; Rated nominal: 5 A; Starting current: 0.005 A rms; Maximum current: 10 A; Fault capture: 14 A peak; Maximum voltage: 288 V rms (Cat IV IEC 61010-1); Overload: 200 A rms for 0.5s, non-recurring; Dielectric withstand: 3250 V ac rms @ 50 Hz for 60 s; Burden: 0.25 VA/phase (@ 5 A); Impedance: 10 mΩ/phase; Rating: Measurement category III
Current: low-current option	Accuracy range: 0.01 A - 6 A autoranging; Rated nominal: 1 A and 2 A; Starting current: 0.001 A rms; Maximum current: 10 A; Fault capture: 14 A peak; Max voltage: 288 V rms (Cat IV IEC 61010-1); Overload: 200 A rms for 0.5s, non-recurring; Dielectric withstand: 3250 V ac rms @ 50 Hz for 60 s; Burden: 0.01 VA/phase (@ 1 A); Impedance: 10 mΩ/phase; Rating: Measurement category III
Control power: single-phase option	Operating range: 85 - 240 V ac (+/- 10%), 47-63 Hz or 110 - 270 V dc (+/- 10%); Rating: Installation category III; Dielectric Withstand: 2000 V ac @ 50 Hz for 60 s

### Sealing capabilities

Protect meter with anti-tamper mechanical sealing and hardware-lock security option.

### Real-time clock and backup battery

Real-time clock synchronises to an internal oscillator or external source. Display year, month, day, hours, minutes, seconds and milliseconds in universal coordinated time (UTC), or display local time based on time-zone settings. A field-replaceable 3.6 V lithium cell maintains the real-time clock if operating power is removed from the meter.

## Front panel

Use for both display and configuration. The FSTN, transreflective backlit LCD provides easy viewing in poor lighting conditions. Multiple programmable screens display numeric values, timestamped values, frequency spectrum (harmonics), phasor diagrams, and name plate data. Alphanumeric text displays support international labels such as OBIS and VDEW.

Navigation buttons move between display screens and aid basic setup procedures. Protected (sealable) buttons provide access for advanced meter configuration, such as meter resets. An IEC 1107 optical serial port facilitates infrared communication with the device. Energy pulser ports and LEDs assist with meter testing, and operational LEDs indicate meter conditions.



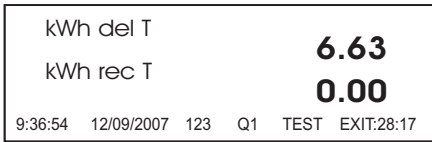

Example numeric display

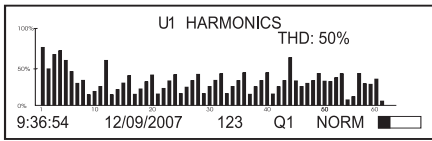

Example histogram display

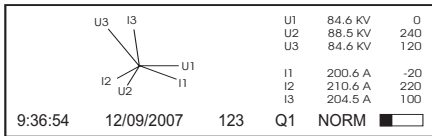

Example phasor display

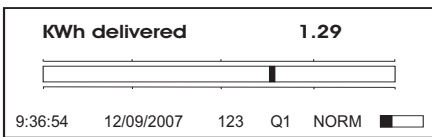

Example disk simulator display

## Power and energy measurements

High-accuracy 4-quadrant metering on any measured value for both 3- and 2-element systems with fully programmable integrating period (1, 5, 10, 15, 30, 60 minutes or other). High-accuracy (1-second) and high-speed (½-cycle) true RMS 3-phase operational measurements for each phase (per phase) and all phases (total).

Measurement	Accuracy <sup>1</sup>
Voltage (line-line) (line-neutral): per phase, total, min/max, unbalance, phase reversal	0,1 % Reading
Current (I1, I2, I3, I4): per phase, total, min/max, unbalance, phase reversal Current demand <sup>2</sup> : present, min/max, predicted	0,1 % Reading
Power: real (kW), reactive (kvar), apparent (kVA) Power demand <sup>2</sup> : present, min/max, predicted	0,2 % Reading
Energy: real (kWh), reactive (kvarh), apparent (kVAh), bidirectional, net, total	IEC 62053-22/23 (0,2S)
Power factor: per phase, total	0,5 %
Frequency U1,U2,U3 (42-69 Hz): per phase, total	0,005 Hz
Crest factor current channels	1 % <sup>3</sup>

1 - Independent compliance with IEC62053-22/23 1st.ed. 2003-01: Static meters for active energy 0,2S and 0,5S. Tested by KEMA.

2 - Selectable block (sliding) or thermal (exponential) demand calculations.

3 - Fundamental >= 5 % nominal, peak current limited to +/- 14 A.

## Power quality

Power quality compliance monitoring for international quality-of-supply standards plus specific data for localised and custom compliance agreements and network connection requirements.

Analyse problems and avoid interruptions. Detect, record and report the specifics of voltage or current imbalances and loss, frequency/power factor variations, over- and under-voltages.

- **Sags/swells (all models):** Voltage waveforms for sags and swells (i.e. ITI (CBEMA) Type 2 and Type 3 disturbances) at 10 ms intervals; report on each disturbance's magnitude and duration. Detect sub-disturbances during a sag/swell event.
- **Harmonics (all models):** Individual harmonics up to the 63rd, K factor and Total Harmonics Distortion (THD).
- **Harmonics (ION8800A and ION8800B):** Voltage and current magnitude, phase and inter-harmonics in accordance with IEC 61000-4-7 (up to the 50th).
- **Transient capture (ION8800A):** Waveforms for transient activity (i.e. ITI (CBEMA) Type 1 disturbances) to 20 µs (50 Hz).
- **Waveform capture (ION8800A):** Selectable waveform recording resolution from 16 samples/cycle to 1024 samples/cycle (800 Hz to 51 kHz). Back-to-back waveform recording allows for extended captures.
- **EN 50160 (ION8800A and ION8800B):** Monitor compliance with EN 50160 parameters.
- **IEC 61000-4-30 class A (ION8800A and ION8800B):** Monitor compliance of relevant IEC 61000-4-30 parameters such as power frequency, magnitude of supply voltage, flicker, supply voltage dips and swells, transients and voltage interruptions. Create compliance reports using PowerLogic ION Enterprise software.

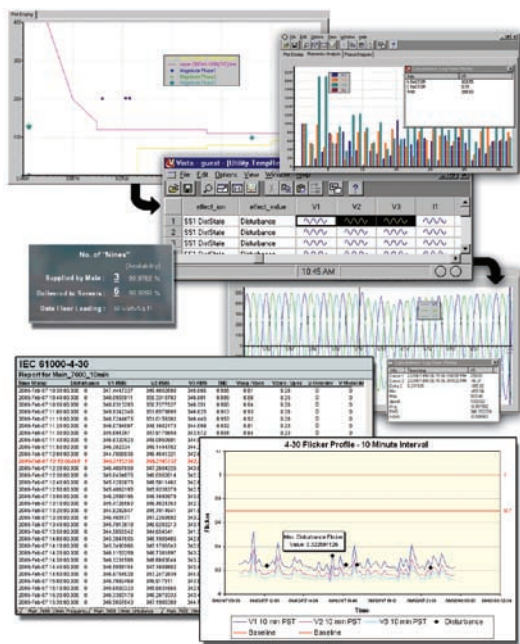

Example screen from PowerLogic ION Enterprise software showing continuous, wide area monitoring, data capture and reporting for power quality and reliability conditions.

## Alarm and control

Each meter has 65 setpoints configurable for 1-second or ½ -cycle operation. Setpoint on any parameter or condition. Use them to trigger audible and visible alarms, data logging, waveform recording, relays, clearing and reset functions, and relative setpoints.

### All ION8800 models

Events	500	500	500	500
Data (years) <sup>A</sup>	1.5	3.1	1.3	2.9
Waveforms	180 <sup>B</sup>	180 <sup>B</sup>	360 <sup>C</sup>	360 <sup>C</sup>

A 16 parameters recorded every 15 minutes

B 30 waveforms on 6 channels at the maximum sampling rate

C 30 waveforms on 12 channels with any selectable format (for example, 6 channels are 512 samples per cycle for 4 cycles, and 6 channels are 32 samples per cycle for 54 cycles)

#### EtherGate and ModemGate

The meters can provide gateway functionality depending on communication options.

**EtherGate:** provides access via ModbusTCP through the meter's Ethernet port to devices communicating via Modbus connected to the meter's serial ports.

**ModemGate:** provides access from the telephone network to devices connected to the meter's serial ports.

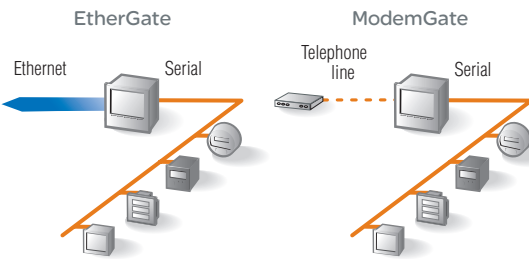

#### Internet connectivity

Exchange information using XML to integrate with custom reporting, spreadsheet, database, and other applications.

**WebMeter:** an on-board web server, provides access to real-time values and PQ data through any web-enabled device and even supports basic meter configuration tasks.

**MeterM@il™:** automatically emails user-configured, high-priority alarm notifications or scheduled system-status update messages to anyone, anywhere within the facility or around the world.

## Data and event logging

Ships with a comprehensive data-logging configuration. Data is prioritised and stored onboard in non-volatile memory to increase the reliability of critical information used for billing and troubleshooting by eliminating data gaps in the event of outages or server downtime. Retrieved data is stored in an ODBC-compliant database when using PowerLogic ION Enterprise software. Logging capacity is available in 5 MB or 10 MB configurations. Default depth and interval of logging is set at the factory, and depends upon onboard memory size.

Meter has data recorders for revenue, losses, historic data, harmonics, waveforms, power system data, sags/swells, transients, events, and EN50160 compliance parameters.

#### Multiple tariffs & time-of-use (TOU) calculations

20-year calendar with automatic leap-year and seasonal adjustments and clock synchronisation over communications channel or GPS supports active, reactive, and apparent energy and demand. TOU configured for 4 seasons, 5 daily profiles per season, and 4 rate periods per daily profile. Automatic mid-season rate change. Automatic recording of maximum (peak) demand during each tariff period. Time switch for tariff control per IEC 62056 and other international standards.

#### IRIG-B time synchronisation option

IRIG-B is the industry standard for GPS time synchronisation. IRIG-B applications include power quality monitoring and sequence of events recording, highly accurate time stamping for revenue billing (1 ms), and system stability monitoring.

## Digital inputs and outputs

Digital inputs are ideal for monitoring status or counting pulses from external dry contacts. Use Form A outputs for end of interval pulsing, load control and alarm annunciation. Use Form C solid-state outputs for load switching applications. Infrared/LED outputs are used for energy pulsing (watt hours and var hours).

Input/ output	Specifications
Digital inputs (DI1 - DI3)	Excitation: External only; Min pulse width: 1 ms; Max pulse rate: 20 Hz; Timing resolution: 1 ms; Updated: ½-cycle (after timing resolution); Isolation: optical; Rating: Installation category II; Frequency range for AC detection: 5 - 210 Hz Low-voltage inputs: Guaranteed OFF range -75 to 5 V dc / V ac (rms), Guaranteed ON range 15 to 75 V dc / V ac (rms), Impedance: 20 kΩ; High-voltage inputs: Guaranteed OFF range -280 to 25 V dc / V ac (rms), Guaranteed ON range 75 to 280 V dc / V ac (rms), Impedance: 100 kΩ;
Form A digital outputs (DO5 - DO12)	Excitation: External only; Maximum switching voltage: 250 V dc or 210 V ac (+/- 300 Vpeak); Maximum switching current: 100 mA ac/dc; Isolation: optical; Update rate: ½-cycle or 1 second (depends on the update rate of the source); Rating: Installation category II
Form C digital outputs (DO1 - DO4)	Excitation: External only; Contacts: common, NO, NC; Maximum switching voltage: 250 V dc or 210 V ac (internally limited to 350 V peak); Maximum switching current: 100 mA ac/dc; Isolation: optical; Update Rate: ½-cycle or 1 second (depends on the update rate of the source); Rating: Installation category II
Mechanical alarm relay / LED	Contacts: common, NO, NC; Maximum switching voltage: 250 V AC / 125 V DC (internally limited to 300 V peak); Maximum switching current: 1 A AC / 0.1 A DC; Operate time (max): 8 ms; Release time (max): 4 ms; Minimum operations: 5,000,000; Update rate: 0.5 cycle or 1 second; Rating: Installation category II

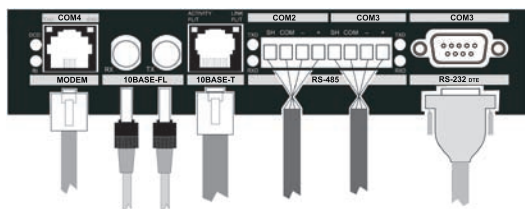

Ports on the Communications module.

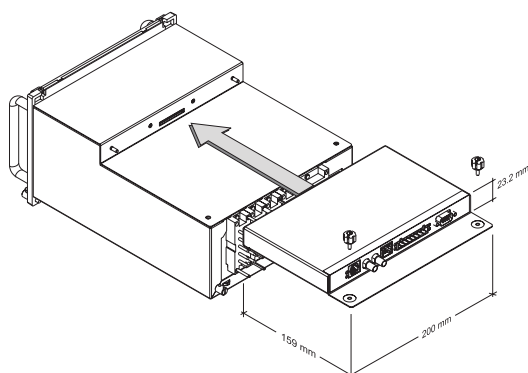

Installing the Communications Module.

## Communications

All meters have an IEC 1107 optical port located on the front of the meter, which is ideal for transferring data to any portable device. Additional concurrent communications ports available as options include RS-485, selectable RS-232/RS-485, internal modem, and Ethernet. The communications module is field replaceable should you desire to upgrade your communications options.

Port	Specifications
IEC 1107 optical (COM 1)	1200 - 19,200 bps; Isolation: Optical; Duplex: Half; Protocols: ION, DNP 3.0, Modbus RTU, DLMS
RS-485 port (COM 2)	300 – 57,600 bps, Connector: captured wire; Isolation: Optical; Duplex: Half Protocols: ION, Modbus RTU, Modbus Master, DNP 3.0, DLMS, GPS, EtherGate, ModemGate
RS-232/RS-485 (COM 3)	300 – 115,200 bps (RS-485 limited to 57,600 bps); Connector: male DB9 (RS-232 DTE) or captured wire (RS-485); Isolation: Optical; Duplex: Full (RS-232), Half (RS-485); Protocols: ION, Modbus RTU, Modbus Master, DNP 3.0, DLMS, GPS, EtherGate, ModemGate
Internal modem (COM 4) <sup>1</sup>	300 bps – 56 kbps; Connector: RJ11 (Tip & Ring); Error correction: V.44, V.42 LAPM, MNP 2-4 ; Data compression: V.42 bis/MNP Class 5
Ethernet (10BASE-T)	Interface: IEEE 802.3-1993, ISO/IEC 8802-3:1993 (Ethernet) 10BASE-T; Data rates: 10 Mbps, half duplex; Connectors: RJ45; Cabling: Unshielded twisted-pair cable, 0.5 mm (24 AWG). Max. length 100 metres; Isolation: Transformer isolated; min isolation voltage 1500 V ac /2250 V dc; Protocols: TCP/IP, Telnet, ION, Modbus TCP, Modbus Master
Ethernet (10BASE-FL)	Interface: IEEE 802.3-1993, ISO/IEC 8802-3:1993 (Ethernet) 10BASE-FL (optional); Data rates: 10 Mbps, half duplex; Connectors: ST; Cabling: Fibre optic cable, 62.5/125 um nominal, wavelength 820 nm Max. length 2000 metres; Isolation: Optical; Protocols: TCP/IP, Telnet, ION, Modbus TCP, Modbus Master

1 - Approved for use in: Argentina, Australia, Austria, Belgium, Brazil, Canada, Chile, China, Cyprus, Czech Republic, Denmark, Estonia, Finland, France, Germany, Greece, Hong Kong, Hungary, Iceland, India, Indonesia, Ireland, Israel, Italy, Japan, Korea, Latvia, Liechtenstein, Lithuania, Luxembourg, Malaysia, Malta, Mexico, Netherlands, New Zealand, Norway, Philippines, Poland, Portugal, Russia, Singapore, Slovak Republic, Slovenia, South Africa, Spain, Sweden, Switzerland, Taiwan, Thailand, Turkey, United Kingdom, United States.

## Software integration

Integrate within PowerLogic facility-level or enterprise-wide power and energy management systems. Real-time data and data logs stored onboard can be automatically retrieved on a scheduled basis for analysis at the system level. Compatible with PowerLogic ION Enterprise. Modbus compatibility and register-based logged data supports integration and data access by building automation, SCADA and other third-party systems.

## Special features

Downloadable firmware: update your meters with the latest features by simply downloading them from [www.powerlogic.com](http://www.powerlogic.com).

## General specifications

Description	Specification
Mounting location	Indoor use
Maximum altitude	2000 metres above sea level
Operating range	-25° C to +55° C (no ice formation)
Display operating range	-10° C to +60° C
Storage range	-25° C to +70° C
Relative humidity range	5 to 95 % non-condensing
Enclosure rating	IP51 (IEC60529)
Safety/construction	IEC 62052-11 1st.ed. 2003-02: Electricity metering equipment (AC) - part 11: General requirements, tests and conditions.
Utility approvals	MARIA, GOST, ESKOM
Immunity	ESD: IEC61000-4-2 (EN61000-4-2/IEC801-2); Radiated EM Field: IEC61000-4-3 (EN61000-4-3/IEC801-3); Electric Fast Transient: IEC61000-4-4 (EN61000-4-4/IEC801-4); Surge: IEC61000-4-5 (EN61000-4-5/IEC801-5); Conducted: IEC61000-4-6 (EN61000-4-6/IEC801-6); Damped oscillatory waves: IEC61000-4-12 (EN61000-4-12/IEC801-12);
Emissions	CISPR 22 Radiated/Conducted Emissions (Class B)

Feature	A <sup>1</sup>	B	C
<b>Revenue metering &amp; standards</b>			
IEC 62053-22 class 0,2S compliant	■	■	■
MV-90 on serial, modem & Ethernet ports (if present)	■	■	■
<b>Power quality</b>			
Sag/swell monitoring	■	■	■
Symmetrical components: zero, positive, negative	■	■	■
Harmonics: individual, even, odd, total (up to 63rd)	■	■	■
Harmonics: magnitude, phase and interharmonics	■	■	-
EN50160 compliance monitoring	■	■	-
IEC 61000-4-30 class A <sup>2</sup>	■	■	-
IEC 61000-4-15 (Flicker)	■	■	-
Configurable for IEEE519-1992, IEEE1159-1995	■	-	-
Transient detection, waveform capture	■	-	-
<b>Communications &amp; I/O</b>			
Modbus TCP Master / Slave (Ethernet port)	■/■	■/■	-/■
Modbus RTU Master (serial ports) / Slave (serial, modem & optical ports)	■/■	■/■	-/■
DLMS & DNP 3.0 via serial, modem & optical ports	■	■	■
IEC 1107 optical port standard on front of meter	1		
RS-485 port selectable on Essailec connector (A only) or communication module (A, B, C)	1		
RS-232/485 port / Internal modem / Ethernet port optional on communications module	1 / 1 / 1		
EtherGate, WebMeter, ModemGate, MeterM@il	■	■	■
Active/Reactive energy pulser, visible LED and IEC61107 style port	■	■	■
Digital pulse outputs (Form C) / Alarm relay output (Form C)	4 / 1		
Digital pulse outputs (Form A) (Optional) / Digital inputs (Optional)	8 / 3		
<b>Logging and recording</b>			
Historical logs, maximum # of channels	800	640	32
Waveform logs, maximum # of cycles per log	96	-	-
Consecutive waveform cycles captured per MB	900	-	-
Memory capacity, standard / optional	5 MB / 10 MB		
Max data points per MB (channels x depth per recorder)	165,000		
Timestamp resolution in seconds	0.001		
Min/max logging for any parameter	■	■	■
GPS time synch (standard on serial; optional on IRIG-B)	■	■	■
Power line time synchronisation	■	■	■
<b>Setpoints, alarming &amp; control</b>			
Setpoints, number / minimum response time	65 / ½ cycle		
Math, logic, trig, log, linearisation formulas	■	■	■
Call-out on single & multi-condition alarms	■	■	■

1 - The meter is available in three different base models: ION8800A, ION8800B and ION8800C.

2 - Independent compliance by Power Standards Laboratories

Schneider Electric  
 35 Rue Joseph Monier  
 CS 30323  
 92506 Rueil Malmaison Cedex  
 Tel : +33 (0)1 41 29 70 00  
 www.schneider-electric.com www.powerlogic.com

As standards, specifications and designs develop over time, always ask for confirmation of the information given in this publication. ION, ION Enterprise, Modbus, and PowerLogic are either trademarks or registered trademarks of Schneider Electric. All other trademarks are property of their respective owners.

PLSED106005EN 11-2008 ART 819800  
 ©2008 - Schneider Electric - All rights reserved

Publishing: Schneider Electric Production: Schneider Electric PMC  
 Printing: Imprimerie du Pont de Claix - made in France

 Printed on recycled paper



"The 2007 award recognizes Schneider Electric for its technological advancements and wide product range in the field of power quality (PQ) and energy management solutions. In total, this is the fourth award that Schneider Electric and [recently acquired] Power Measurement have received from Frost & Sullivan in recognition of achievements in this arena."  
 Prithvi Raj, Frost & Sullivan research analyst



Certificate No. 002188

Please contact your local sales representative for ordering information.

Visit [www.powerlogic.com](http://www.powerlogic.com) for more information on other PowerLogic products, applications and system solutions.