

PowerLogic™ ION8800

Energy & Power Quality Meter

Installation Guide



Danger



This symbol indicates the presence of dangerous voltage within and outside the product enclosure that may constitute a risk of electric shock, serious injury or death to persons if proper precautions are not followed.

Caution



This symbol alerts the user to the presence of hazards that may cause minor or moderate injury to persons, damage to property or damage to the device itself, if proper precautions are not followed. **Consult this document whenever this symbol is used on the meter, to determine the nature of the potential hazard and any actions which need to be taken.**

Note



This symbol directs the user's attention to important installation, operating and maintenance instructions.

Installation Considerations

Installation and maintenance of the ION8800 meter should only be performed by qualified, competent personnel that have appropriate training and experience with high voltage and current devices. The meter must be installed in accordance with all local and national electrical codes.

If this equipment is used in a manner not specified by the manufacturer, the protection from electric shock, fire, etc. provided by this equipment may be impaired.

DANGER

Failure to observe the following instructions may result in severe injury or death.

- ◆ During normal operation of the ION8800 meter, hazardous voltages are present on its connector pins, and throughout the connected potential transformer (PT), current transformer (CT), direct connect without PTs, digital (status) input, control power and external I/O circuits. PT and CT secondary circuits are capable of generating lethal voltages and currents with their primary circuit energized. Follow standard safety precautions while performing any installation or service work (i.e. removing PT fuses, shorting CT secondaries, etc).
- ◆ Do not use digital output devices for primary protection functions. These include applications where the devices perform energy limiting functions or provide protection of people from injury. Do not use the ION8800 in situations where failure of the devices can cause injury or death, or cause sufficient energy to be released that can start a fire. The meter can be used for secondary protection functions.
- ◆ The ION8800 meter's chassis ground must be properly connected to a good earth ground for safety, and for the noise and surge protection circuitry to function correctly. Failure to do so will void the warranty, and create a risk of electric shock, injury or death.
- ◆ When installing the meter, all voltage paths (measurement voltage and all auxiliary circuits such as the power supply and the tariff control voltage) must be fused according to applicable local safety standards.

CAUTION

Observe the following instructions, or permanent damage to the meter may occur.

- ◆ The ION8800 meter offers a range of hardware options that affect input ratings. The ION8800 meter's serial number label lists all equipped options. Applying current levels incompatible with the current inputs will permanently damage the meter. This document provides installation instructions applicable to each hardware option.
- ◆ Do not HIPOT/Dielectric test the digital (status) inputs, digital outputs, power supply terminals or communications terminals. Refer to the label on the ION8800 meter for the maximum voltage level the device can withstand.
- ◆ Replacing the meter battery with the wrong type or voltage rating could result in damage to the meter. Use only a lithium LiSOCl₂ battery with a rated voltage of 3.6 V, and the same construction as the original battery, as a replacement.

Network Compatibility Notice for the Internal Modem

The internal modem in meters equipped with this option is compatible with the telephone systems of most countries in the world. Use in some countries may require modification of the internal modem's initialization strings. If problems using the modem on your phone system occur, please contact Schneider Electric Technical Support.

Standards Compliance



Made by Power Measurement Ltd.

PowerLogic, ION, ION Enterprise, MeterM@il, WebMeter and Modbus are either trademarks or registered trademarks of Schneider Electric.

Covered by one or more of the following patents:

U.S. Patent No's 7010438, 7006934, 6990395, 6988182, 6988025, 6983211, 6961641, 6957158, 6944555, 6871150, 6853978, 6825776, 6813571, 6798191, 6798190, 6792364, 6792337, 6751562, 6745138, 6737855, 6694270, 6687627, 6671654, 6671635, 6615147, 6611922, 6611773, 6563697, 6493644, 6397155, 6236949, 6186842, 6185508, 6000034, 5995911, 5828576, 5736847, 5650936, D505087, D459259, D458863, D443541, D439535, D435471, D432934, D429655, D427533.

ION8800 Models

Feature Set	Description
C	Basic Tariff/Energy revenue meter
B	Feature Set C + EN50160 and IEC 61000-4-30 Class A compliant power quality monitoring
A	Feature Set B + power quality analysis (waveforms and transient capture with 1024 samples/cycle resolution)

Available Options

Logging and Recording	Current Inputs	Communications	Security
<ul style="list-style-type: none"> ◆ 5 MB memory ◆ 10 MB memory 	<ul style="list-style-type: none"> ◆ Low Current (In=1A, 2A) ◆ High Current (In=5A) 	<ul style="list-style-type: none"> ◆ Optical IEC 1107 ◆ RS-485 and optical IEC 1107 ◆ Communications Module (RS-485, RS-232, modem, 10-Base-T Ethernet, 10-Base-FL Fiber Ethernet) 	<ul style="list-style-type: none"> ◆ Standard ◆ Hardware locked

I/O Options

Ordering Code	Outputs	Digital Inputs	Com
A	<ul style="list-style-type: none"> ◆ 8 digital Form A solid-state outputs ◆ 1 Form C mechanical relay ◆ 4 Form C solid-state outputs 	None	One RS-485 port on Essailec connector
B	<ul style="list-style-type: none"> ◆ 8 digital Form A solid-state outputs ◆ 1 Form C mechanical relay ◆ 4 Form C solid-state outputs 	3 Low voltage	None
C	<ul style="list-style-type: none"> ◆ 8 digital Form A solid-state outputs ◆ 1 Form C mechanical relay ◆ 4 Form C solid-state outputs 	3 High voltage	None
D	<ul style="list-style-type: none"> ◆ 1 Form C mechanical relay ◆ 4 Form C solid-state outputs ◆ IRIG-B 	3 Low voltage	One RS-485 port on Essailec connector
E	<ul style="list-style-type: none"> ◆ 1 Form C mechanical relay ◆ 4 Form C solid-state outputs ◆ IRIG-B 	3 High voltage	One RS-485 port on Essailec connector

Before You Begin

Before installing the meter, familiarize yourself with the steps in this guide and read the safety precautions presented on the "Installation Considerations" page.

Meter Overview

Meter Front (Cover Closed)

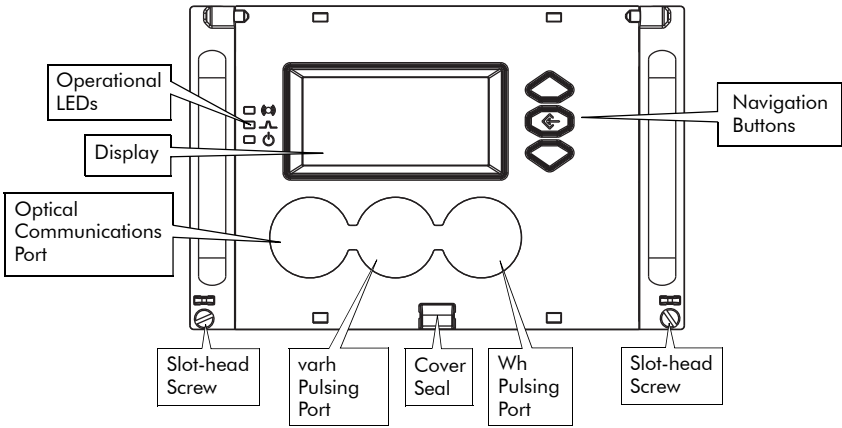

Meter Front (Cover Open)

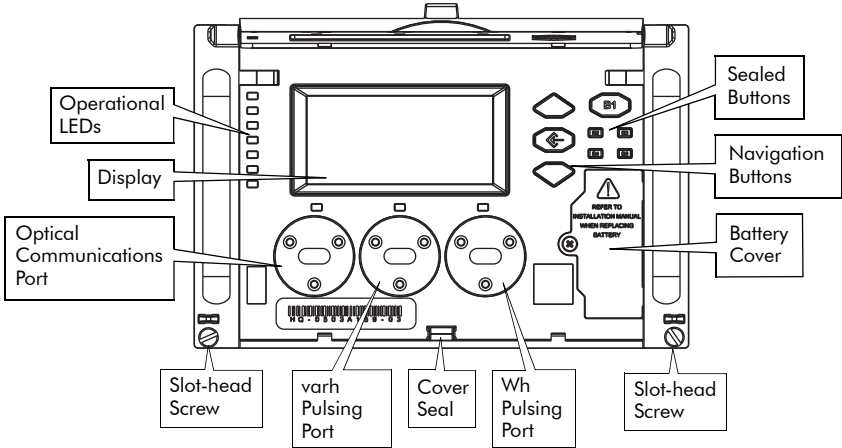

Meter Back

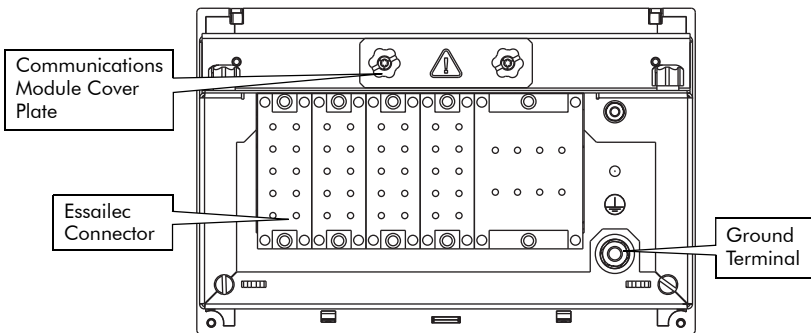

Front Panel Button Functions



ALT/ENTER: Press this button once to enter ALT mode. Press and hold to enter Setup mode. In Setup mode, press this button to accept changes.



NAVIGATION: Press the UP / DOWN arrow buttons to highlight menu items, or increment / decrement numbers. Press and hold to shift cursor left and right.



DEMAND RESET: Press this button to reset all maximum demand registers. Not accessible when cover is sealed.



TEST MODE: Press this button to enter Test Mode. Billable quantities do not accumulate when meter is in Test Mode. Not accessible when cover is sealed.



ALT CONFIG: Press this button to enter the Alternate Configuration menu. Not accessible when cover is sealed.



MASTER RESET: Press this button to reset meter quantities. Not accessible when cover is sealed.



SPARE: This button is not currently implemented. Not accessible when cover is sealed.

Meter Labels

Front of Meter (Cover Closed)

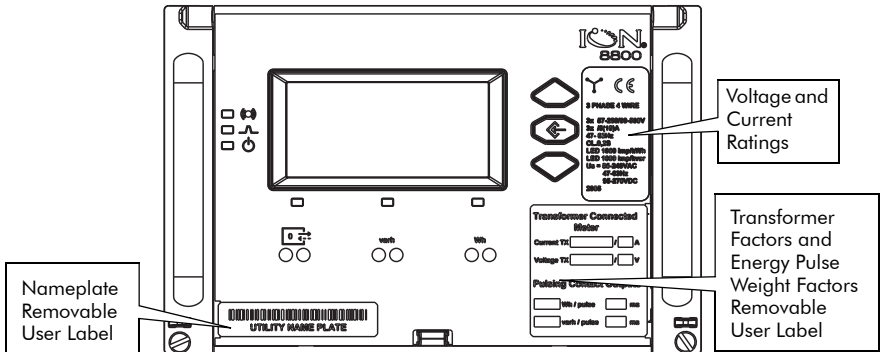

Removable User Labels

Insert user labels between bezel label and plastic lid while cover is open.

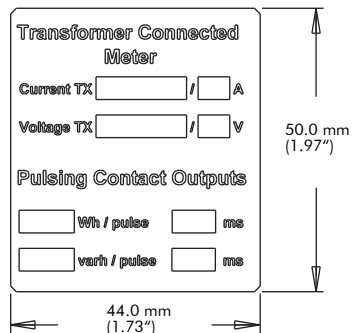
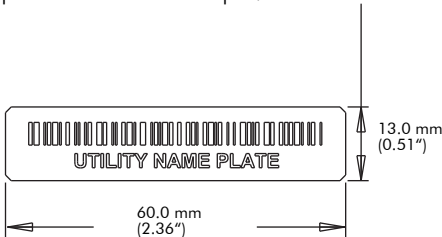

Unit Dimensions

Meter dimensions conform to DIN standard 43862.

Front View of Meter

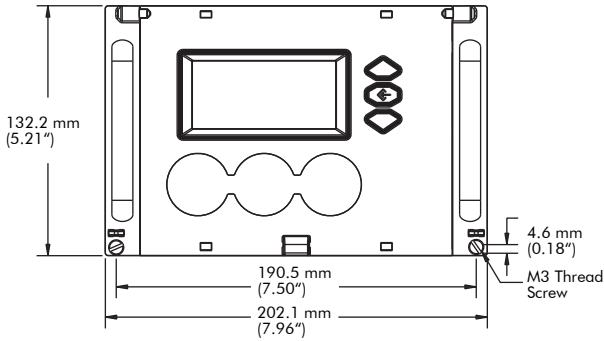

Side View of Meter

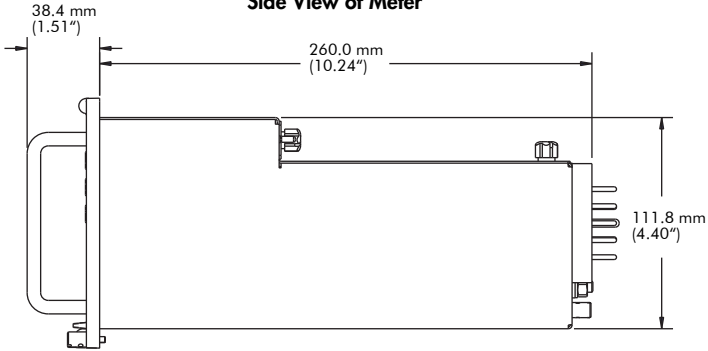

Front of Rack View

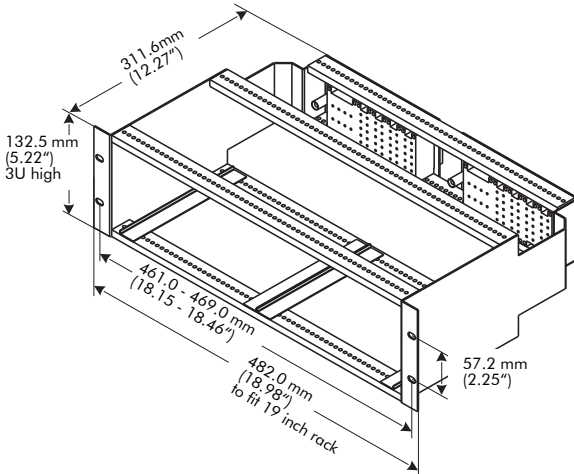

Essailec Connections



Voltage, current, power supply, I/O and communication connections are made via the Essailec connector on the rear of the meter. Meters can be ordered with multiple connector configurations.

Order Options B/C Circuit & Pinout Diagrams





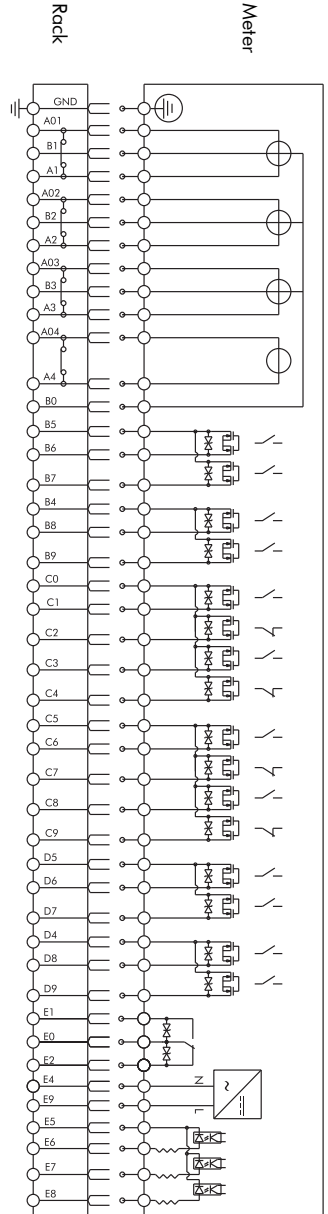



This pinout drawing details the various pins on the meter side of the connector. The table below maps the pins to their corresponding inputs and outputs in the meter.

Code 13	Code 17	Code 15	Code 13	
● 5	● 5	● 5	● 5	● 04
● 6	● 6	● 6	● 6	● 03
● 7	● 7	○ 2	● 7	● 02
● 8	○ 3	● 8	● 8	● 01
● 9	● 9	● 9	● 9	● 00



Order Option A Circuit & Pinout Diagrams

This pinout drawing details the various pins on the meter side of the connector. The table below maps the pins to their corresponding inputs and outputs in the meter.

 Code 15	 Code 17	 Code 15	 Code 13	 Code 07	 Code 05	 Code 03	 Code 01
5 ● 6 ● 7 ● 8 ○ 9 ●	5 ● 6 ● 7 ● 8 ● 9 ●	5 ● 6 ● 7 ● 8 ● 9 ●	5 ● 6 ● 7 ● 8 ● 9 ●	5 ● 6 ● 7 ● 8 ● 9 ●	5 ● 6 ● 7 ● 8 ● 9 ●	5 ● 6 ● 7 ● 8 ● 9 ●	01 ● 02 ● 03 ● 04 ●

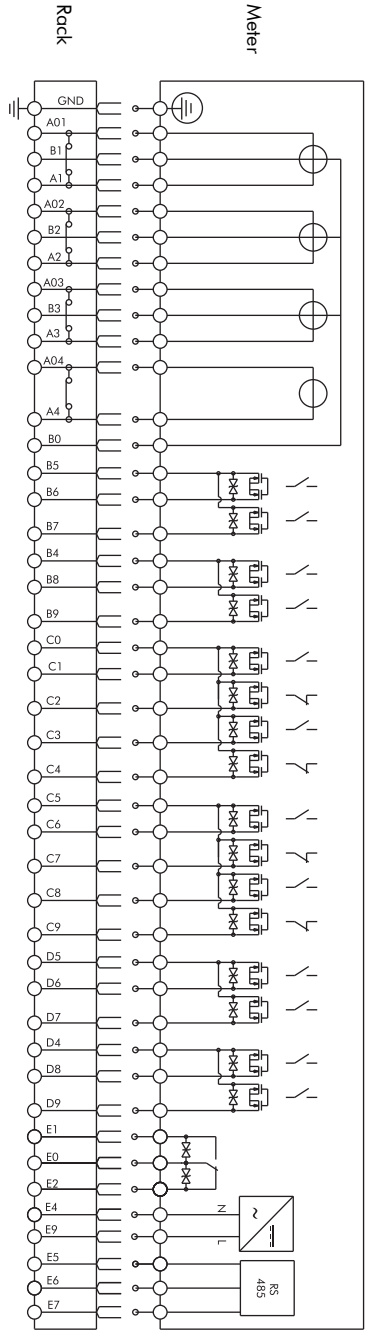

E D C B A

Order Options A/B/C Essailec Connector Arrangement

	Meter Port	Essailec Connector Pin	Description
Current Measurement Inputs	I11	A01	standard
	I12	A1	standard
	I21	A02	standard
	I22	A2	standard
	I31	A03	standard
	I32	A3	standard
	I41	A04	optional
	I42	A4	optional
Voltage Measurement Inputs	Uref	B0	standard
	U1	B1	standard
	U2	B2	standard
	U3	B3	standard
Form A Outputs	DO7 & DO8 K	B4	standard; Common
	DO5 & DO6 K	B5	standard; Common
	DO5	B6	standard; NO
	DO6	B7	standard; NO
	DO7	B8	standard; NO
	DO8	B9	standard; NO
Form C Solid-state Relays	DO1 & DO2 K	C0	standard; Common
	DO1	C1	standard; NO
	DO1	C2	standard; NC
	DO2	C3	standard; NO
	DO2	C4	standard; NC
	DO3 & DO4 K	C5	standard; Common
	DO3	C6	standard; NO
	DO3	C7	standard; NC
	DO4	C8	standard; NO
	DO4	C9	standard; NC
Unused	-	D0	Unused
	-	D1	Unused
	-	D2	Unused
	-	D3	Unused
Form A Outputs	DO11 & DO12 K	D4	standard; Common
	DO9 & DO10 K	D5	standard; Common
	DO9	D6	standard; NO
	DO10	D7	standard; NO
	DO11	D8	standard; NO
	DO12	D9	standard; NO
Form C Mechanical Relay	Alarm K	E0	standard; Common
	Alarm	E1	standard; NO
	Alarm	E2	standard; NC

	Meter Port	Essailec Connector Pin	Description
Digital Inputs or RS-485 Com	DI-SCOM (or RS-485 Shield)	E5	standard; Common
	DI1 (or RS-485 +)	E6	RS-485 +
	DI2 (or RS-485 -)	E7	RS-485 -
	DI3 (or unused)	E8	standard
	-	E3	Unused
Power Supply Inputs (AC/DC)	Power Supply N/-	E4	Power Supply neutral (-)
	Power Supply L/+	E9	Power Supply line (+)

Order Options D/E Circuit & Pinout Diagrams

This pinout drawing details the various pins on the meter side of the connector. The table below maps the pins to their corresponding inputs and outputs in the meter.

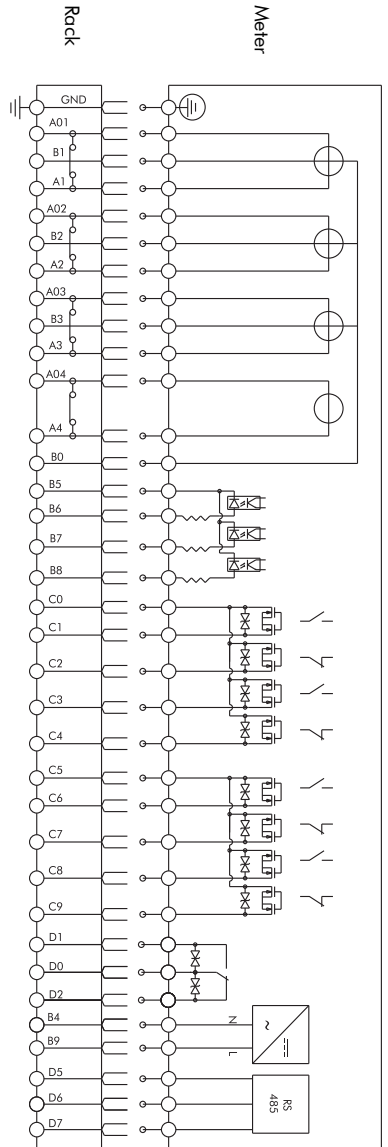

D C B A

Code 15	Code 15	Code 15	04 03 02 01 4 3 2 1
5 ●	5 ●	5 ●	
6 ●	6 ●	6 ●	
7 ●	7 ●	7 ●	
8 ○	8 ○	8 ○	
9 ●	9 ●	9 ●	
Code 07	Code 03	Code 05	

Order Options D/E Essailec Connector Arrangement

	Meter Port	Essailec Connector Pin	Description
Current Measurement Inputs	I11	A01	standard
	I12	A1	standard
	I21	A02	standard
	I22	A2	standard
	I31	A03	standard
	I32	A3	standard
	I41	A04	optional
	I42	A4	optional
Voltage Measurement Inputs	Uref	B0	standard
	U1	B1	standard
	U2	B2	standard
	U3	B3	standard
Digital Inputs	DI-SCOM	B5	standard; Common
	DI1	B6	standard
	DI2	B7	standard
	DI3	B8	standard
Power Supply Inputs (AC/DC)	Power Supply N/-	B4	Power Supply neutral (-)
	Power Supply L/+	B9	Power Supply line (+)
Form C Solid-state Relays	DO1 & DO2 K	C0	standard; Common
	DO1	C1	standard; NO
	DO1	C2	standard; NC
	DO2	C3	standard; NO
	DO2	C4	standard; NC
	DO3 & DO4 K	C5	standard; Common
	DO3	C6	standard; NO
	DO3	C7	standard; NC
	DO4	C8	standard; NO
DO4	C9	standard; NC	
Form C Mechanical Relay	Alarm K	D0	standard; Common
	Alarm	D1	standard; NO
	Alarm	D2	standard; NC
	-	D3	Unused
RS-485 Com	RS-485 Shield	D5	RS-485 Shield
	RS-485 +	D6	RS-485 +
	RS-485 -	D7	RS-485 -
	-	D8	Unused
IRIG-B Clock Synchronization Input	IRIG-B input common	D4	optional; clock synch input Common
	IRIG-B input	D9	optional; clock synch input

Step 1: Mount the Meter

Meter Battery Considerations

The meter's battery life expectancy depends on both temperature and the amount of time the meter is without power. For typical installations, the battery should last 10 years minimum at 25°C meter ambient operating temperature. The battery is field replaceable (see "Replacing the Battery" on page 37).

Environmental Specifications (IEC62052-11)

Mounting Location	Indoor use
Metrological	-10 to +45°C (14 to +113°F)
Operating Range	-25 to +55°C (-13 to +131°F) No formation of ice
Max. Altitude	2000 metres (6562 feet) above sea level
Display Operating Range	-10 to +60°C (14 to +140°F)
Storage Range	-25 to +70°C (-13 to +158°F)
Relative Humidity Range	5 to 95% non-condensing
Enclosure Rating	IP51 (IEC60529)

Installation

DANGER

Do not power up the meter until the ground terminal is connected -- risk of electric shock.



Meter Ground Terminal

1. Connect the ground terminal on the rear of the meter to a good earth ground on the rack, using a 3.3 mm² (12 AWG) wire. Ensure that the terminal nut is tightened down securely onto the ground wire. The wire must be a minimum of 30 cm long (11.8") to allow racking and unranking.
2. Slide the meter into the DIN standard 43862 rack (half-width 19 inch/ 482.6 mm rack with plug-in Essailec connector).

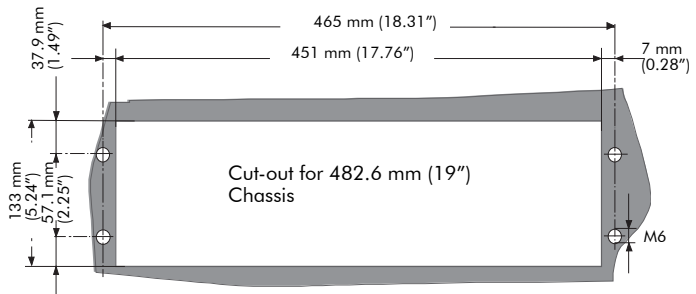

3. Ensure the rear connector fits tightly.
4. Tighten the two slot-head screws (M3 thread) into the front of the meter rack, to hold the meter firmly in place.

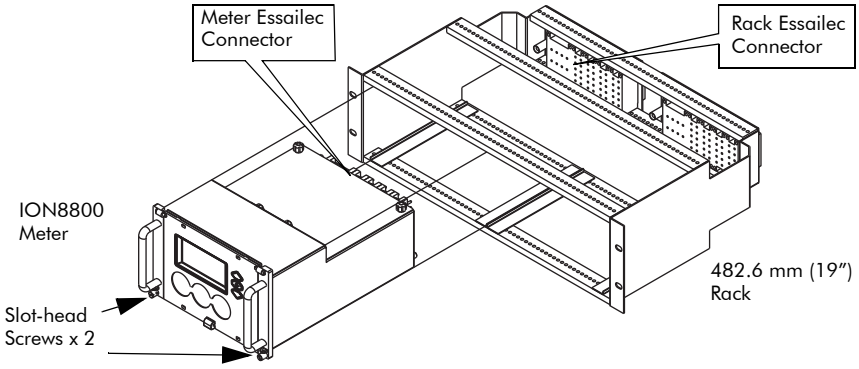

Step 2: Wire the Digital I/O

Form C Digital Output: Mechanical Alarm Relay

Contacts	common, NO, NC
Max. Switching Voltage	250 VAC/125 VDC (internally limited to 300 V peak)
Max. Switching Current	1 A AC/0.1 A DC
Operate Time (max.)	8 ms
Release Time (max.)	4 ms
Isolation to Ground	2,000 VAC for 60 s (50 Hz)
Rating	Installation category II (local), Pollution degree 2
Minimum Operations	5,000,000

Form C Digital Output: Solid State Relay Outputs DO1 - DO4

Excitation	External only
Contacts	common, NO, NC
Max. Switching Voltage	250 VDC/ 210 VAC (internally limited to 350 V peak)
Max. Switching Current	100 mA AC/DC
Isolation to Ground	2,000 VAC for 60 s (50 Hz)
Rating	Installation category II (local), Pollution degree 2

Form A Digital Outputs: Solid State Relay Outputs DO5 - DO12

Excitation	External only
Max. Switching Voltage	250 VDC/ 210 VAC (internally limited to 350 V peak)
Max. Switching Current	100 mA AC/DC
Isolation to Ground	2,000 VAC for 60 sec. (50 Hz)
Rating	Installation category II (local), Pollution degree 2

Digital Inputs: Solid State DI1 - DI3

Excitation	External only
Minimum Pulse Width	1 ms
Maximum Pulse Rate	20 Hz
Timing Resolution	1 ms
Updated	½ cycle (does not affect timing resolution)
Isolation to Ground and to Contacts	2,000 VAC for 60 sec. (50 Hz)

Rating	Installation category II (local), Pollution degree 2
Hi-Voltage Range	75 - 280 VDC or VAC (RMS)
Lo-Voltage Range	15 - 75 VDC or VAC (RMS)
Hi-Voltage Input Impedance	100 k Ω
Lo-Voltage Input Impedance	20 k Ω

 **CAUTION**

Field Hi-Pot testing to the above isolation levels is not recommended -- risk of meter damage.

Step 3: Wire the Voltage and Current Inputs

Voltage Inputs

Inputs	U1, U2, U3, Uref
Accuracy and Rating Range	57 - 288 L-N VAC RMS 99 - 500 L-L VAC RMS
Fault Capture	1200 V peak (L-N)
Overload	1500 VAC RMS continuous
Dielectric Withstand	3320 VAC RMS at 50 Hz for 60 s
Input Impedance	5 M Ω /phase (phase - Vref)
Rating	Measurement category IV

CAUTION

Applications where the system voltages exceed 230 L-N VAC RMS must have wired power supply only.

Current Inputs: High Current Option

Accuracy Range	0.05 - 10 A autoranging
Rated Nominal	5 A
Starting Current	0.001 A RMS
Max. Current	10 A
Fault Capture	14 A peak
Max. Voltage	288 V RMS (Cat IV IEC 61010-1)
Overload	200 A RMS for 0.5 s, non-recurring
Dielectric Withstand	3320 VAC RMS at 50 Hz for 60 s
Burden	0.25 VA per phase (at 5 A)
Impedance	10 mΩ per phase
Rating	Measurement category IV

Current Inputs: Low Current Option

Accuracy Range	0.01 - 6 A autoranging
Rated Nominal	1 A and 2 A
Starting Current	0.001 A RMS
Max Current	10 A
Fault Capture	14 A peak
Max. Voltage	288 V RMS (Cat IV IEC 61010-1)
Overload	200 A RMS for 0.5 s, non-recurring
Dielectric Withstand	3320 VAC RMS at 50 Hz for 60 s
Burden	0.01 VA per phase (at 1 A)
Impedance	10 mΩ per phase
Rating	Measurement category IV

NOTE

The appropriate Volts Mode setting is included with each wiring diagram. Refer to Step 7 to learn how to configure Volts Mode on the meter.

CT & PT Selection

Consult your local instrument transformer expert, either at the local utility or through a vendor or supplier, to obtain CT and PT selection standards for high accuracy revenue metering applications in your regions.

4-Wire Wye, 3-Element, Direct Connection Diagram

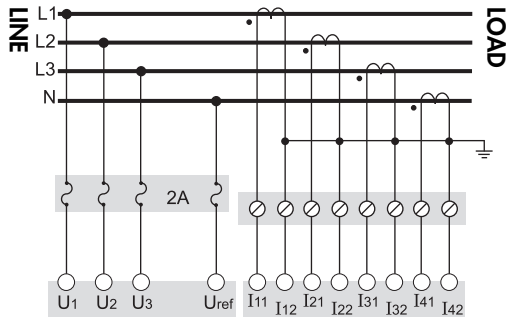

288 V L-N / 500 V L-L max.

VOLTS MODE = 4W-Wye

4-Wire Wye, 3-Element, 3 PTs Connection Diagram

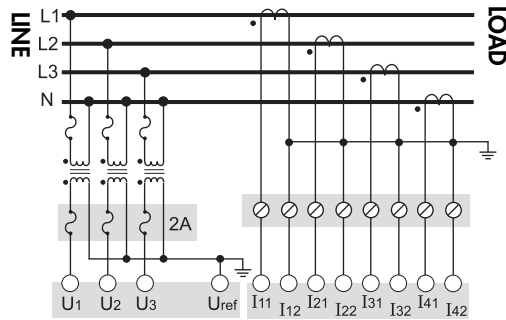

Use PTs for voltages over 288 V L-N / 500 V L-L.

Wye (Star) wiring for PT primaries and secondaries.

VOLTS MODE = 4W-Wye

4-Wire Wye, 2½-Element, 2 PTs Connection

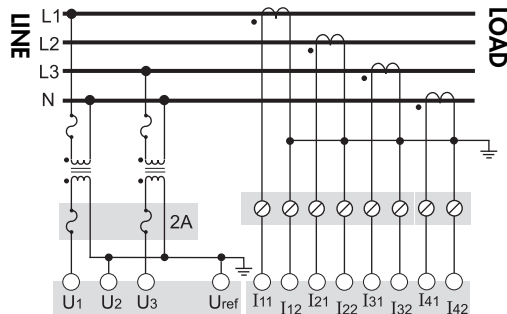

Phase 2 voltage (U2) displayed by meter is derived from phase 1 and phase 3, not measured. U2 will display a value even if no voltage is present on Phase 2. U2 values are only accurate for balanced loads.

VOLTS MODE = 3W-Wye

3-Wire Solid-Grounded Wye, 3-Element, Direct Connection

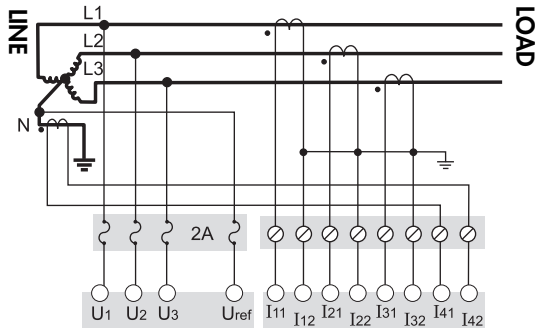

When the common or star point of a 3-wire Wye system is grounded, the meter may be connected directly without using PTs, provided that the phase voltages are within the meter's range.

VOLTS MODE = 4W-Wye

3-Wire Delta, 2½-Element, Direct Connection

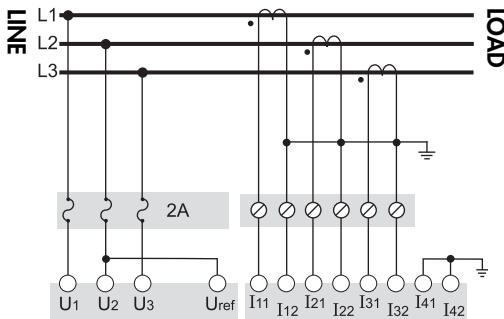

500 V L-L max.

VOLTS MODE = Delta

3-Wire Delta, 2-Element 2 PTs & 2 CTs

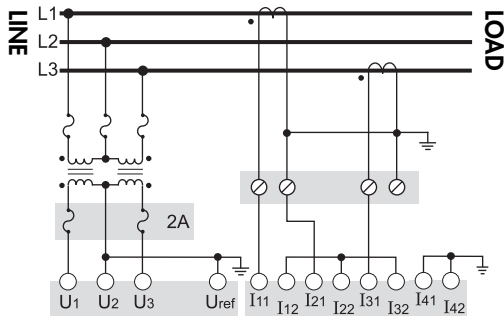

Use PTs for voltages over 500 V L-L.

VOLTS MODE = Delta

3-Wire Delta, 2½-Element, 2 PTs & 3 CTs

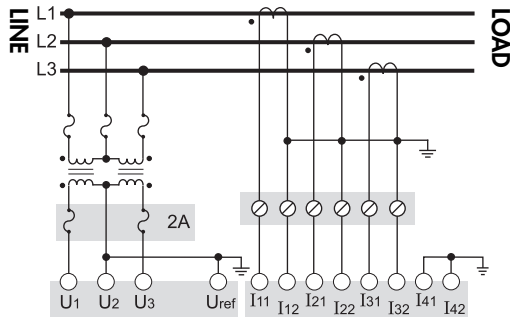

Use PTs for voltages over 500 V L-L

VOLTS MODE = Delta

Single Phase Connection Diagram

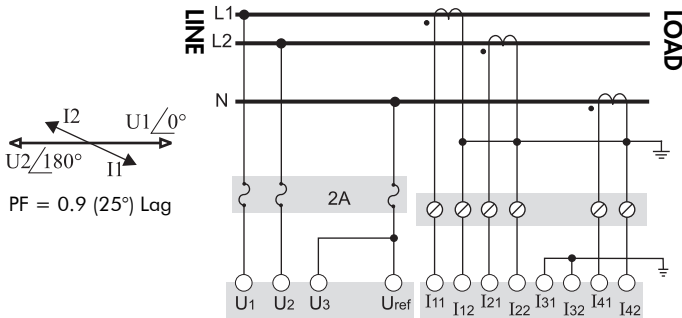

288 V L-N / 500 V L-L max. Use PTs for higher voltages.

VOLTS MODE = Single

Using Potential Transformers

System Mode	Voltage Range	Requires PTs
Wye/ Single Phase	up to 288 V L-N or 500 V L-L	no
	over 288 V L-N or 500 V L-L	yes
Delta	up to 480 V L-L	no
	over 480 V L-L	yes

Step 4: Wire the Communications

ION8800 meters are equipped with one standard optical port. Other communications ports are available as options.



The Communications module cover plate (found on the back of the meter) should never be removed unless a communications module is installed in its place.

Infrared Connections (COM1)

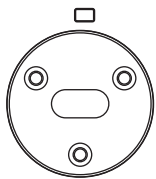

Connect an optical probe cable (not included) to communicate between the meter optical port and a PC serial port.

Interface	IEC 1107 optical port
Location	Front of meter
Data Rate	1,200 – 19,200 bps
Isolation	Optical
Duplex	Half

RS-485 Connections (COM2 and COM3)

Ports Available	COM2: optional module or Essaielc COM3: optional module only
Connectors	Captured-wire (+, -, Common*, Shield)
Wire	Shielded 2 or 3-conductor RS-485 cable
Maximum Cable Length	1219 m (4,000 ft) total for entire bus
Data Rate	300 – 57,600 bps
Maximum Devices (per bus)	32
Isolation	Optical
Duplex	Half

* Use optional Common wire for improved communications performance.

RS-232 Connections (COM3 optional module)

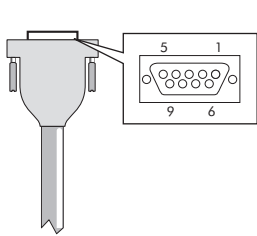

DB9 Null Modem Wiring Diagram

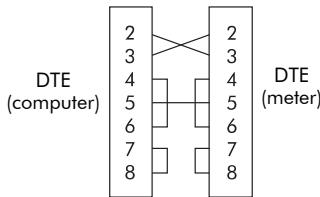

Null modem cable pinout

- Pin 3 - Transmit Data - Pin 2
- Pin 2 - Receive Data - Pin 3
- Pin 7 - Request to Send- Pin 8
- Pin 8 - Clear to Send- Pin 7
- Pin 5 - Signal Ground- Pin 5
- Pin 6 - Data Set Ready- Pin 4
- Pin 4 - Data Terminal Ready- Pin 6

Specification	Meter Connected to Computer	Meter Connected to External Modem
Connector Type	DB9 female end for mating with male connector on the meter	
Wire	Null modem RS-232 cable	Straight-through RS-232 cable
Maximum Cable Length	15.2 m (50 ft)	

Specification	Meter Connected to Computer	Meter Connected to External Modem
Connector Type	DB9 female end for mating with male connector on the meter	
Data Rate	300 – 115,200 bps	
Isolation	Optical	
Duplex	Full	

Ethernet Connections (optional module)

10Base-T

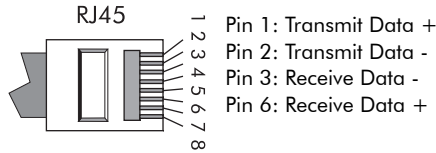

Wire Type	High quality Category 3 or 5 unshielded twisted pair cable
Connector Type	RJ45 modular
Maximum Length	100 m (328 ft)
Type	IEEE 802.3 10Base-T for 10 Mbps base band CSMA/CD LANs
Data Rate	10 Mbps
Isolation	Transformer isolated to 1500 VAC/2250 VDC RMS
Max. Connections Allowed	4 simultaneous

10Base-FL (Fiber)

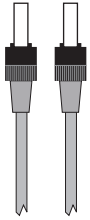

ST type fiber cables

Wire Type	62.5/125 micrometer multimode fiber optic cable
Connector Type	ST
Maximum Length	2000 m (6562 ft)
Data Rate	10 Mbps
Isolation	Optical

 **NOTE**

Ethernet connection should be made to either the Fiber port or RJ45 port, not both, or communications conflicts may result.

Only one EtherGate connection per port is allowed at a time

Ethernet TCP/IP Service Ports

Protocol	Port
ION	7700
Modbus RTU	7701
Modbus TCP	502
EtherGate (COM2)	7802
EtherGate (COM3)	7803
DNP TCP	20,000

Internal Modem Connection (COM4 optional module)

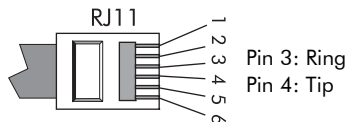

Connector Type	RJ11
Wire Type	Part 68 compliant telephone cord
Data Rate	300 bps – 56 kbps
Error Correction	V.42 LAPM, MNP 2-4, V.44
Data Compression	V.42 bis/MNP 5

Step 5: Wire the Power Supply

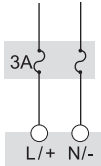

Fuse for N/- terminal required if neutral is ungrounded.

ION8800 power supply connections are found on the Essailec connector.

Single Phase Power Supply

Rated Inputs	85 - 240 VAC \pm 10% (47 - 63 Hz) 110 - 270 VDC \pm 10%
Rating	Installation category II (local), Pollution degree 2
Dielectric Withstand	2,000 VAC RMS for 60s (50Hz)
Max. Burden	9 W (20 VA) for base unit without comm module
Ride-through	Min: 120 ms (6 cycles @ 50 Hz) Typical: 0.5 - 5 s (depending on input voltage and configuration)

Step 6: Power Up the Meter

DANGER

Before you apply power to the meter, ensure that ground is securely connected and that the supply voltage is within the allowed range of the meter's power supply.

Step 7: Set Up the Meter Using the Front Panel

The following Setup screens are available for meter configuration via the front panel:

BASIC SETUP
DEMAND SETUP
COM1 SETUP
COM2 SETUP
COM3 SETUP
COM4 SETUP
NETWORK SETUP
FORMAT SETUP
DISPLAY SETUP
SECURITY SETUP

The following example shows Volts Mode setup using the meter front panel.

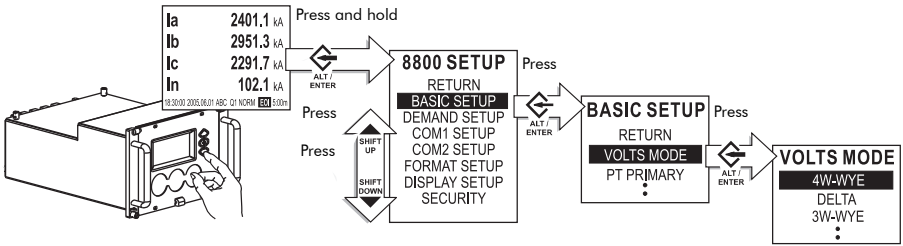

Press ALT/ENTER and hold for 3 seconds to enter Setup Mode from Display Mode.

Use arrow buttons to move up and down in list. Press ALT/ENTER to select Basic Setup.

Use arrow buttons to move up and down in list. Press ALT/ENTER to select Volts Mode.

Use arrow buttons to move up and down in list. Press ALT/ENTER to select 4W-WYE.

The following table lists all settings that can be configured via the front panel, with the meter cover seal in place.

Menu	Setting	Description	Range (Values)	Default
Basic Setup	Volts Mode	The power system's configuration – WYE, DELTA, etc.	4W-WYE DELTA 3W-WYE SINGLE DEMO	4W-WYE
	PT Primary	The Potential Transformer's primary winding voltage rating	1 to 999 999 999	120,00
	PT Secondary	The Potential Transformer's secondary winding voltage rating	1 to 999 999 999	120,00
	CT Primary	The Current Transformer's primary winding current rating	1 to 999 999 999	5
	CT Secondary	The Current Transformer's secondary winding current rating	1 to 999 999 999	5
	I4 Primary	Primary rating for the I4 current transformer	1,0 - 999 999,00	5
	I4 Secondary	Secondary rating for the I4 current transformer	1,0 - 999 999,00	5
	U1 Polarity	The polarity of the Potential Transformer on U1	Normal or Inverted	Normal
	U2 Polarity	The polarity of the Potential Transformer on U2	Normal or Inverted	Normal
	U3 Polarity	The polarity of the Potential Transformer on U3	Normal or Inverted	Normal
	I1 Polarity	The polarity of the Current Transformer on I1	Normal or Inverted	Normal
	I2 Polarity	The polarity of the Current Transformer on I2	Normal or Inverted	Normal
	I3 Polarity	The polarity of the Current Transformer on I3	Normal or Inverted	Normal
	I4 Polarity	The polarity of the Current Transformer on I4	Normal or Inverted	Normal
	Phase Rotation	Power system's phase rotation	123, 132	123

Menu	Setting	Description	Range (Values)	Default
Demand	SWD Subinterval	Intervals used to compute your Sliding Window Demand values	1 to 5 940	600
	SWD # Subintervals	The number of SWD periods in use	1 to 15	3
	SWD Pred Resp		0,00 to 99,00	70
COM1	Protocol	Specifies which protocol is active	ION, Modbus RTU, DNP, DLMS, Factory	ION
	Baud Rate	Specifies COM port baud rate during serial communications	1 200 to 19 200	9 600
	Transmit Delay	Specifies the meter's transmit delay setting (in seconds)	0 to 1,0	0,010
	Unit ID	Identifies the meter during serial communications	1 to 9 999	From serial number ²
	Serial Port	Parity and stop bits for the port	8N1,8N2,8E1,8E2,8O1,8O2	8N1
COM2	Protocol	Specifies which protocol is active	ION, Modbus RTU, Modbus Master ³ , DNP, DLMS, EtherGate, ModemGate, GPS: Truetime/Datum GPS: Arbiter, Factory	ION
	Baud Rate ¹	Specifies COM port baud rate during serial communications	300 to 57 600	9 600
	Transmit Delay	Specifies the meter's transmit delay setting (in seconds)	0 to 1,0	0,010
	Unit ID	Identifies the meter during serial communications	1 to 9 999	From serial number ²
	Serial Port	Parity and stop bits for the port	8N1,8N2,8E1,8E2,8O1,8O2	8N1
	Port Location	Specifies physical connection point for COM2	Essailec or Comm Module	Essailec
COM3	Protocol	Specifies which protocol is active	Same as COM2	ION
	Baud Rate ¹	Specifies COM port baud rate during serial communications	300 to 115 200 (RS-485 limited to 57 600 bps)	9 600
	Transmit Delay	Specifies the meter's transmit delay setting (in seconds)	0 to 1,0	0,010
	Unit ID	Identifies the meter during serial communications	1 to 9999	From serial number ²
	Serial Port	Parity and stop bits for the port	8N1,8N2,8E1,8E2,8O1,8O2	8N1
	RS-232 or RS-485	Specifies RS-232 or RS-485	RS-232, RS-485	RS-232
	RTS/CTS Handshake	Specifies if hardware flow control is used during RS-232 communication	RTS with delay RTS/CTS	RTS + delay
COM4	Protocol	Specifies which protocol is active	ION, Modbus RTU, DNP, DLMS, GPS: Truetime/Datum GPS: Arbiter, Factory	ION
	Baud Rate ¹	Specifies COM port baud rate during serial communications	300 to 115 200	9 600
	Transmit Delay	Specifies the meter's transmit delay setting (in seconds)	0 to 1,0	0,010
	Unit ID	Identifies the meter during serial communications	1 to 9 999	From serial number ²

Menu	Setting	Description	Range (Values)	Default
Network Setup	IP Address	Specifies TCP/IP Ethernet address	000.000.000.000 to 255.255.255.255	None
	Mask	Specifies Subnet Mask	0.0.0.0 to 255.255.255.0	None
	Gateway	Specifies Ethernet gateway (if used)	000.000.000.000 to 255.255.255.255	None
	SMTP Address	Specifies location of SMTP Server	000.000.000.000 to 255.255.255.255	None
Format	Phase Labels	Specifies how phases are labelled	ABC, RST, XYZ, RYB, 123	123
	PF Symbol	LD (leading)/LG (lagging)	LD/LG, +/-, CAP/IND	LD/LG
	Digit Group	Specifies symbols used to delimit thousands and decimal place holder	1000.0 or 1,000.0 or 1000,0	1000,0
	Date Format	Specifies how dates are displayed	MM/DD/YYYY, DD/MM/YYYY, YYYY/MM/DD	MM/DD/YYYY
	Show DST	Determines if DST is shown or not	Yes or No	Yes
	Volts Decimal	Number of decimal places displayed for voltages	1. to 123 456 789,XXX	1,XX
	Current Decimal	Number of decimal places displayed for currents	1. to 123 456 789,XXX	1,XXX
Display	Power Decimal	Number of decimal places displayed for power measurements	1. to 123 456 789,XXX	1,XXX
	Update Rate	Sets when the display updates (in seconds)	1 to 6	1
	Contrast	Higher numbers are sharper	0 to 9	7
	Backlight Timeout	Specifies the time it takes (in seconds) for the backlight to turn off (0 = the display stays lit indefinitely)	0 to 7 200 (two hours)	300 (five minutes)
	DMD Lock	Controls the minimum allowable time between consecutive demand resets (in seconds)	0 (disabled) to 5 184 000 (60 days)	216 000 (25 days)
	TEST Mode TO	Defines how long the meter remains in TEST mode before switching back to NORM mode		30 minutes
	Display Scale	Determines the scale applied to displayed parameters	1 to 999 999	1000
	Scaling Mode	Specifies whether parameters are divided or multiplied by the scale before being displayed	Multiply or Divide	Divide
Security	Delta Vectors	Specifies how vector diagrams are displayed when in Delta mode	System or Instrument	System
	Modify Passwd	Modifies standard password	0 to 999 999 999	0
	Disable Security	Disables meter security	Disabled or Enabled	Enabled
	Web Config	Allow configuration via web server	Disabled or Enabled	Enabled
	Ack Alarms	Sends a pulse to acknowledge alarms when selected	-	-

¹ A baud rate of 300 bps is only intended for paging applications.

² Serial number = PA-0302B**222**-01, Unit ID = **222**

³ Available on ION8800A and B meters only.

The following table lists all settings that can be configured using the ALT CONFIG menu (not available when meter cover is sealed).

Setting	Description	Range (Values)	Default
IR Config	Allows meter configuration via the front optical port	Disabled or Enabled	Enabled
Meter Lock ¹	When meter is locked, most meter configuration is prevented, as are meter resets	Locked or Unlocked	Locked ²
Clear Alarms	Sends a pulse to clear alarms when pushed	-	-

¹ After a meter is unlocked, it automatically relocks if you do not perform any configuration for 30 minutes. This function is not available on non-hardware lockable meters.

² Default = 'Locked' on meters ordered with Hardware Lock option. Default = 'Unlocked' on all other meters (setting is non-functioning).

Step 8: Verify Meter Operation

Three LEDs on the left-hand side of the Front Panel indicate the following:



Alarm (red) Top LED is user programmable; by default, it flashes to indicate serious meter faults. Contact Technical Support if this occurs.



Indicator (green) Middle LED is user programmable.



Power (green) Bottom LED indicates the meter is powered. The light should always remain on when the meter is in service.

Phasor Diagrams

You can also view the meter's phasor diagram in real time. Use the Phasor Viewer available in ION Setup v2.1 and later (free to download from the website) to verify your meter's wiring. See the ION Setup online help for details.

NOTE

The following DELTA phasor diagrams are represented in system mode.

DELTA phasors for UNITY Power Factor (resistive load)

Applicable Volts Mode = DELTA

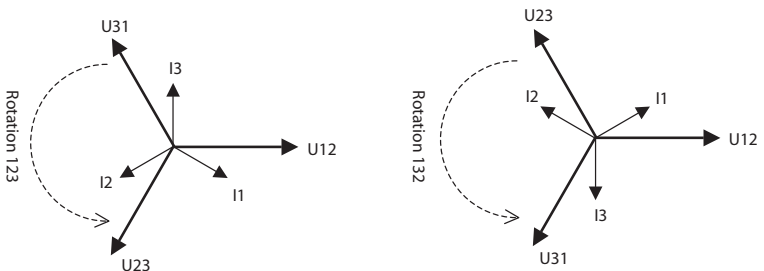

WYE - 123 Rotation

Applicable Volts Mode = 4W-WYE and 3W-WYE

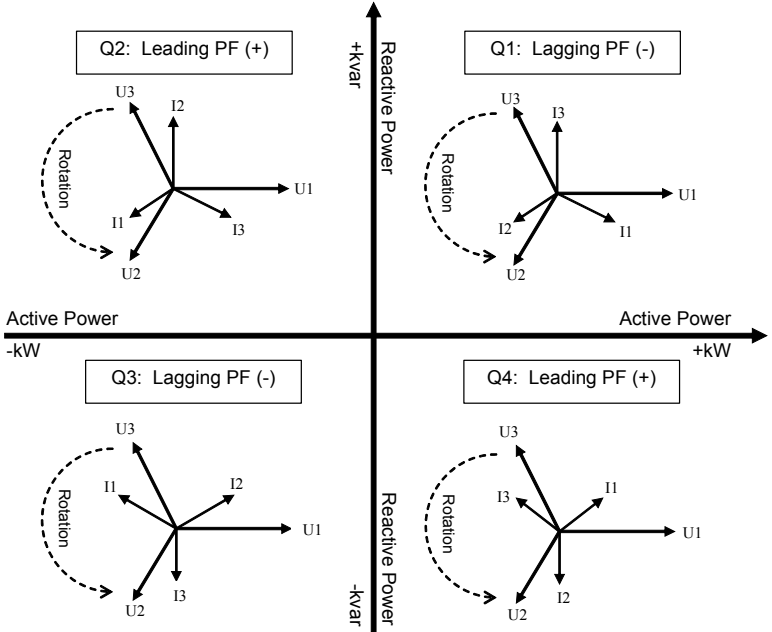

WYE - 132 Rotation

Applicable Volts Mode = 4W-WYE and 3W-WYE

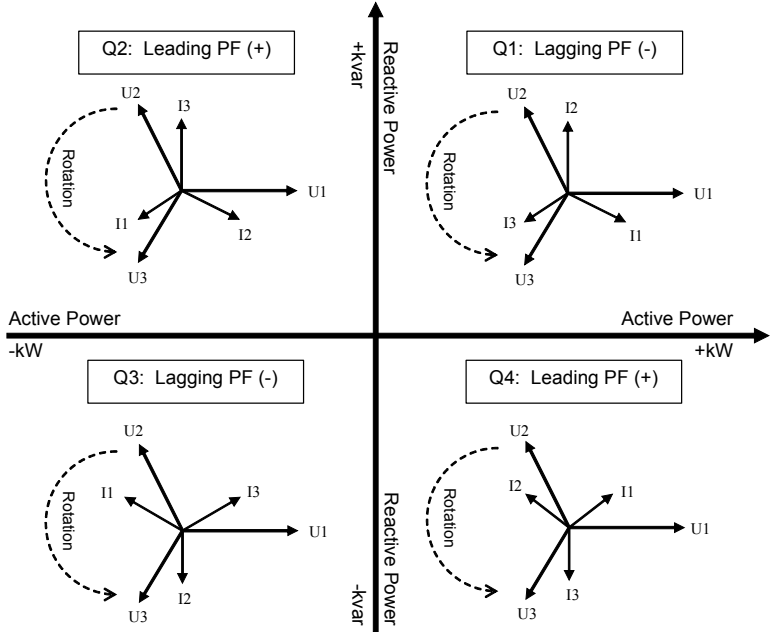

2 Element (3Wire) DELTA - 123 Rotation

Applicable Volts Mode = DELTA

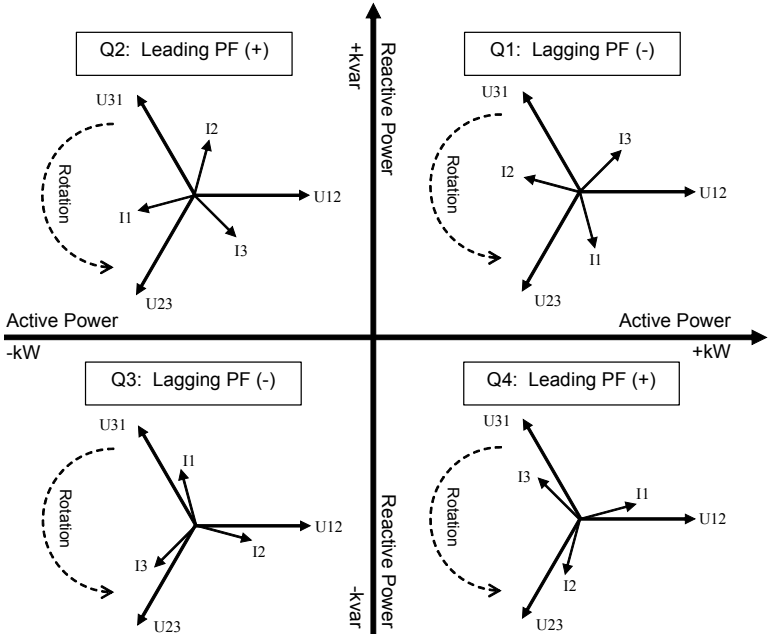

2 Element (3Wire) DELTA - 132 Rotation

Applicable Volts Mode = DELTA

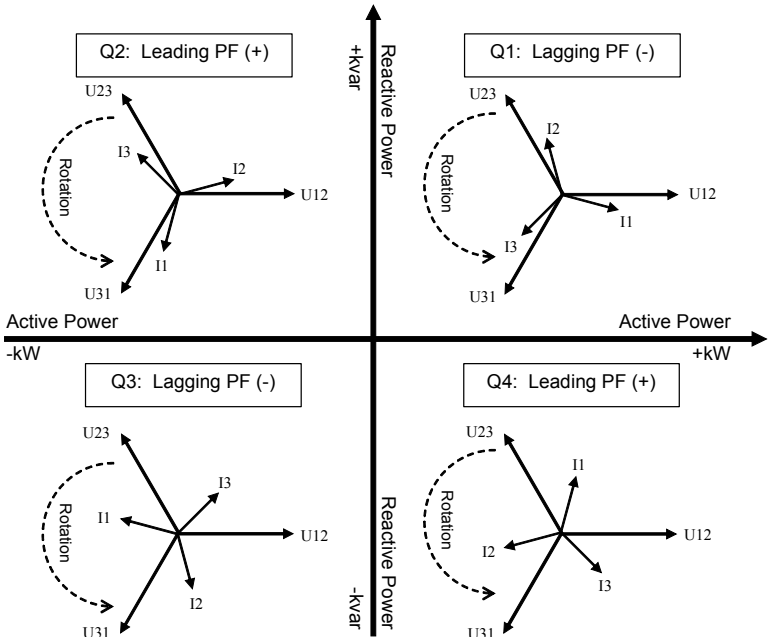

Step 9: View Meter Data

NORM mode

Use the **Up** and **Down** buttons to scroll through **NORM** mode display screens.

NORM Screen	Contents
kWh	kWh delivered/received
kvarh	kvarh delivered/received
kVAh	kVAh delivered/received
Peak Demand Delivered	Maximum delivered kW value (timestamped)
Peak Demand Received	Maximum received kW value (timestamped)
Peak Demand Reset	Number of Demand Resets (timestamped)
Q Metering	Approximated varh measurements
Disk Simulator	Simulates mechanical watt-hour meter disk
All Segments	Black screen to indicate functioning display

ALT mode

Press the **Alt/Enter** button once for **ALT** display modes. Press the **Up** or **Down** buttons to scroll through displays.

ALT Screen	Contents
Name Plate 1	Owner, firmware version, TAG 1 & 2, meter serial number
Name Plate 2	Sliding window settings
Event Log	Most recent high priority (255) events
Vector Diagram	Phasors and values for phase current/voltage
Instantaneous Voltage	Average voltage, L-N or L-L
Instantaneous Current	Phase current, average current
Instantaneous Power	kW total, kvar total, kVA total, power factor
Instantaneous Demand	kW delivered/received
Voltage Harmonics (3 screens)	Per-phase voltage harmonic histograms
Current Harmonics (3 screens)	Per-phase current harmonic histograms
Availability	Number of nines measurement
Instantaneous Demand	kW delivered/received

TOU Display Screen	Contents
TOU Energy by Rate	kWh delivered values for each TOU rate
kW Peak Demand	Maximum kW delivered for each TOU rate
Previous Billing Energy	kWh delivered in PB
Prev Billing Peak Demand	Maximum kW delivered in PB
Previous Season Energy	kWh delivered for each TOU rate in PB
Prev Season Peak Demand	Max kW delivered for each TOU rate in PB
Prev Billing/Season Energy	kWh delivered/received in PB & billing season
Prev Bill/Season Pk Dem	Max kW sd received from PB & billing season
Prev Billing/Season Energy	kvarh del/rec in PB & billing season
Prev Bill/Season Pk Demand	kvar del/rec in PB & billing season
Prev Billing/Season Energy	kVAh del/rec from PB & billing season
Pre Bill/Season Pk Demand	kVA del/rec in PB & billing season
Active TOU Rate	Active TOU billing rate
Active TOU Season	Active TOU billing season
Flicker	Flicker measurements from U1, U2 & U3
Frequency	Frequency information

 **NOTE**

PB = Previous Billing period.

TEST Mode

TEST Screen	Contents
kWh Test	TEST mode kWh delivered/received
kvarh/KVAh Test	TEST mode kvarh/KVAh delivered/received
Instantaneous Demand Test	TEST mode kW delivered/received

To Enter TEST Mode

Meter Type	Method
Standard Meter (no hardware lock)	Use ION software
	Open cover and press TEST mode button (see "Front Panel Button Functions" on page 7)
Hardware Locked Meter	Open cover and press TEST mode button (see "Front Panel Button Functions" on page 7)

 **NOTE**

The meter always returns to NORM mode after exiting TEST mode.

Replacing the Battery



The battery in the ION8800 meter keeps the real time clock running when supply power is lost. Replace the battery if the meter has been stored for an extended period of time without power (longer than two years). If the meter will be without power for an extended length of time, disconnect the battery cable so that the battery maintains its 10-year shelf life.

Battery Specifications

Type	Lithium LiSOCl ₂
Nominal Capacity	1.0 Ah
Rated Voltage	3.6 V
Connector	Gold-plated

Battery Dimensions

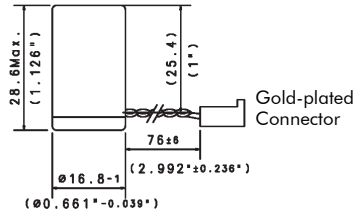

The battery can be changed when the meter is either powered or unpowered.

NOTE

Replacing the battery on an unpowered meter resets the internal clock and may affect revenue parameters.

To replace the battery

1. To prevent electrostatic damage to the unit, make sure you are grounded or wear an anti-static wrist strap during this procedure.
2. Open the front cover of the meter.
3. Remove the Phillips screw that holds the battery cover in place and remove the battery cover.
4. Remove the battery from the housing and disconnect the battery connector from the meter.

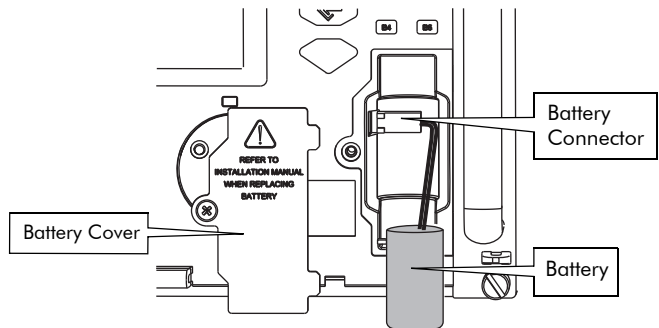

5. Connect the new battery's wire to the meter, and place the battery in the housing.
6. Replace the battery cover and the Phillips screw.
7. Close the cover of the meter.

Meter Security

Security features depend on the meter ordering options. See below.

All ION8800 meters

Standard security includes traditional anti-tamper mechanical sealing points on the meter case and cover.

ION8800 meters with Hardware Locked Security Option

Standard security plus a hardware-locked security system that prevents modification of revenue quantities after the meter is sealed.

Hardware Locked Security Option

To make configuration changes to billing parameters on a hardware-locked meter, you must first unlock the meter. The Meter Lock setting is located in the ALT Config menu, which is reached by pressing the ALT Config button under the anti-tamper sealed cover (see “ALT Config Button” on page 7). This button cannot be activated remotely with a Hardware Lock meter.

Typical values that are protected include:

- ◆ kWh, kvarh, kVAh delivered, received, del-rec, del+rec.
- ◆ kW, kvar, kVA and Sliding Window demand min and max values.
- ◆ Digital Outputs controlling the energy pulsing applications.
- ◆ All Power system settings, including PT and CT ratios.

For a complete list of locked values specific to your meter and its firmware, contact Technical Support.

Anti-Tamper Sealing Methods

The ION8800 meter uses the following anti-tamper sealing methods.

Meter Seals

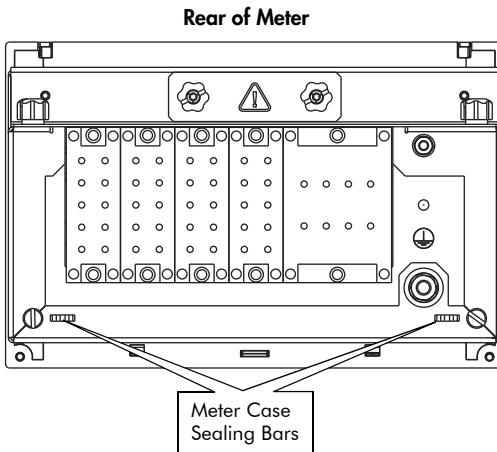

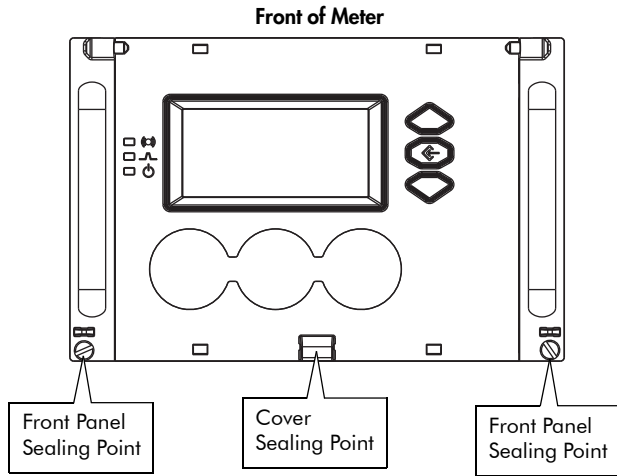

The meter incorporates sealing bars and chassis screws with through-holes, through which traditional lead/wire seals can be inserted. When utilized, these lead/wire seals effectively prevent unauthorized personnel from gaining access to meter internals or to buttons under the cover.

These seals are installed as follows:

1. Insert the sealing wire through **both** the screw hole and sealing bar.

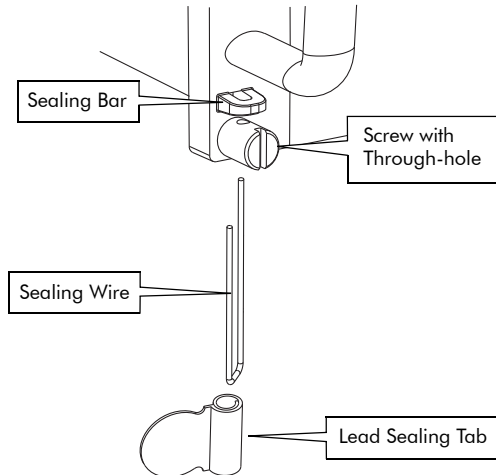

2. Twist the wire and crimp the lead-sealing tab on to the wire.

PowerLogic™ ION8800

with WebMeter™ and MeterM@ii™

Installation Guide

For further assistance
please contact us at:

Schneider Electric

Power Monitoring and Control
2195 Keating Cross Road
Saanichton, BC
Canada V8M 2A5
Tel: 1-250-652-7100

295 Tech Park Drive, Suite 100
Lavergne, TN 37086
USA
Tel: 1-615-287-3400

Electropole (38 EQI)
31, rue Pierre Mendès France
F - 38050 Grenoble Cédex 9
Tel : + 33 (0) 4 76 57 60 60

Getting technical support:
Contact your local Schneider Electric sales
representative for assistance or go to the
www.global.powerlogic.com website.

ION, ION Enterprise, MeterM@ii, Modbus, Power
Measurement, PowerLogic, Schneider Electric, Square D
and WebMeter are either trademarks or registered
trademarks of Schneider Electric in France, the USA and
other countries. All other trademarks are property of their
respective owners.

Electrical equipment should be installed, operated,
serviced, and maintained only by qualified personnel.
No responsibility is assumed by Schneider Electric for any
consequences arising out of the use of this material.

70002-0291-00

© 2008 Schneider Electric. All rights reserved.
05/2008