

# PowerLogic™ ION8600

Energy and power quality meter

Installation guide





## Important Information

Read these instructions carefully and examine the equipment to become familiar with the device before trying to install, operate, or maintain it. The following special messages may appear throughout this documentation or on the equipment to warn of potential hazards or to call attention to information that clarifies or simplifies a procedure.

### Danger



This symbol indicates the presence of dangerous voltage within and outside the product enclosure that may constitute a risk of electric shock, serious injury or death to persons if proper precautions are not followed.

### Caution



This symbol alerts the user to the presence of hazards that may cause minor or moderate injury to persons, damage to property or damage to the device itself, if proper precautions are not followed.

### Note



This symbol directs the user's attention to important installation, operating and maintenance instructions.

## Installation Considerations

Installation and maintenance of the ION8600 meter should only be performed by qualified, competent personnel that have appropriate training and experience with these types of devices and their associated equipment. A qualified person is one who has skills and knowledge related to the construction and operation of this type of electrical equipment installations and has received safety training to recognize and avoid the associated hazards. The meter must be installed in accordance with all local and national electrical codes.

No responsibility is assumed by Schneider Electric for any consequences arising out of the use of this material.



### **DANGER**

Failure to follow these instructions will result in death or serious injury.

- ◆ During normal operation of the ION8600 meter, hazardous voltages are present on its terminal strips, and throughout the connected potential transformer (PT), current transformer (CT), digital (status) input, control power and external I/O circuits. PT and CT secondary circuits are capable of generating lethal voltages and currents with their primary circuit energized. Follow appropriate safety precautions while performing any installation or service work (i.e. removing PT fuses, shorting CT secondaries, etc).
- ◆ The ION8600 meter must be installed with chassis ground. Ground the device before power is applied. Proper grounding of the meter is necessary for the following reasons:
  - Safety of personnel working with the meter.
  - Protection of the electronic circuitry in the meter.
  - Proper operation of noise filtering within the meter.
  - Proper operation of communication ports.
  - Compliance with all local and national regulations on grounding electrical devices.
 The meter's grounding tab, ground terminal or ground wire (in case of meters powered from auxiliary power source) must be connected to the protective earth ground before the meter is powered up.
- ◆ The ION8600 is designed to be used as a permanently installed device. All electrical connections to the meter must be installed with a permanent connection method.
- ◆ Install fuses (customer supplied) in all voltage measurement inputs and auxiliary (control) power circuits.
- ◆ All electrical connections on the meter terminals should not be user-accessible after installation.
- ◆ Do not use the ION8600 outputs for primary protection functions. These include applications where the devices perform energy limiting functions or provide protection of people from injury. Do not use the ION8600 in situations where failure of the device can cause injury or death, or cause sufficient energy to be released that can start a fire.

 **CAUTION**

Failure to follow these instructions can result in equipment damage and void the warranty.

---

- ◆ Do not HIPOT/Dielectric test the digital (status) inputs, digital outputs, or communications terminals. Refer to the applicable section in this manual for the maximum voltage level the terminal can withstand.
- ◆ The ION8600 meter offers a range of hardware options that affect input ratings. The ION8600 meter's serial number label lists all equipped options. Applying current levels incompatible with the current inputs will permanently damage the meter. This document provides installation instructions applicable to each hardware option.
- ◆ Recommended terminal screw torque for voltage and current inputs (switchboard meters only) is 2.82 Nm (25 in-lbs) max. Recommended terminal screw torque for auxiliary power supply inputs (switchboard meters only) is 1.01 Nm (9 in-lbs) max.

## FCC Notice

This equipment has been tested and found to comply with the limits for a Class B digital device, pursuant to part 15 of the FCC Rules. These limits are designed to provide reasonable protection against harmful interference in a residential installation. This equipment generates, uses, and can radiate radio frequency energy and, if not installed and used in accordance with the instructions, may cause harmful interference to radio communications. However, there is no guarantee that interference will not occur in a particular installation. If this equipment does cause harmful interference to radio or television reception, which can be determined by turning the equipment off and on, the user is encouraged to try to correct the interference by one or more of the following measures.

- ◆ Reorient or relocate the receiving antenna
- ◆ Increase the separation between the equipment and receiver.
- ◆ Connect the equipment to an outlet on a circuit different from that to which the receiver is connected.
- ◆ Consult the dealer or an experienced radio/TV technician for help.

This Class B digital apparatus complies with Canadian ICES-003.

The Ringer Equivalence Number (REN) for the ION8600 optional internal modem is 0.6. Connection to the ION8600 internal modem should be made via an FCC Part 68 compliant telephone cord (not supplied). The ION8600 cannot be used on a public coin phone service or party line services.

## Network Compatibility Notice for the Internal Modem

The internal modem in meters equipped with this option is compatible with the telephone systems of most countries in the world, with the exception of Australia and New Zealand. Use in some countries may require modification of the internal modem's initialization strings. If problems using the modem on your phone system occur, please contact Schneider Electric Technical Support

Made by Power Measurement Ltd.

Covered by one or more of the following patents:

U.S. Patent No's 7010438, 7006934, 6990395, 6988182, 6988025, 6983211, 6961641, 6957158, 6944555, 6871150, 6853978, 6825776, 6813571, 6798191, 6798190, 6792364, 6792337, 6751562, 6745138, 6737855, 6694270, 6687627, 6671654, 6671635, 6615147, 6611922, 6611773, 6563697, 6493644, 6397155, 6236949, 6186842, 6185508, 6000034, 5995911, 5828576, 5736847, 5650936, D505087, D459259, D458863, D443541, D439535, D435471, D432934, D429655, D427533.

# ION8600 Models

The PowerLogic™ ION8600 meter is available in socket or switchboard form factors.

## Socket Meter

The socket meter is designed to fit into S-Base meter sockets and A-to-S Base adapters. Form factors supported include: 9S, 35S, 36S, 39S, and 76S.

## Switchboard Meter

The switchboard meter eliminates the need for shorting blocks by providing shorting blocks within the drawout case. All voltage and current connections are made via terminals located on the rear of the switchboard case. When the meter is removed from the draw-out case, current inputs are short-circuited by the test switches on the shorting blocks.

Switchboard meters can be ordered with an optional breakout panel that provides easy onboard I/O and communications connections.

## RMICAN Model

A socket or switchboard meter that is Industry Canada certified for revenue metering in Canada. Different security options are available, including a factory-sealed version.

## Feature Sets

ION8600 meters are available with three different feature sets:

- ◆ **ION8600A** includes 10 MB memory, 50 data recorders (800 channels), waveform recorders, transient detection, flicker, interharmonics, Modbus Mastering and an additional serial port.
- ◆ **ION8600B** includes 4 MB memory, 20 data recorders (320 channels), Modbus Mastering and an additional serial port.
- ◆ **ION8600C** includes 2 MB memory, 2 data recorders (32 channels) and sag/swell detection.

# In this Guide

This guide contains the following sections. Your workflow may not specifically align with the steps outlined below:

- ◆ "Meter Overview" on page 6
- ◆ "Meter Labels" on page 7
- ◆ "Step 1: Mount the Meter" on page 9
- ◆ "Step 2: Wire the Ground Terminal" on page 12
- ◆ "Step 3: Wire the Onboard I/O (optional)" on page 13
- ◆ "Step 4: Wire the Voltage and Current Inputs" on page 17
- ◆ "Step 5: Wire the Communications" on page 27
- ◆ "Step 6: Wire the Power Supply" on page 31
- ◆ "Step 7: Power Up the Meter" on page 32
- ◆ "Step 8: Set Up Meter Using the Front Panel" on page 33
- ◆ "Step 9: Verify Meter Operation" on page 37
- ◆ "Step 10: View Meter Data" on page 40

# Meter Overview

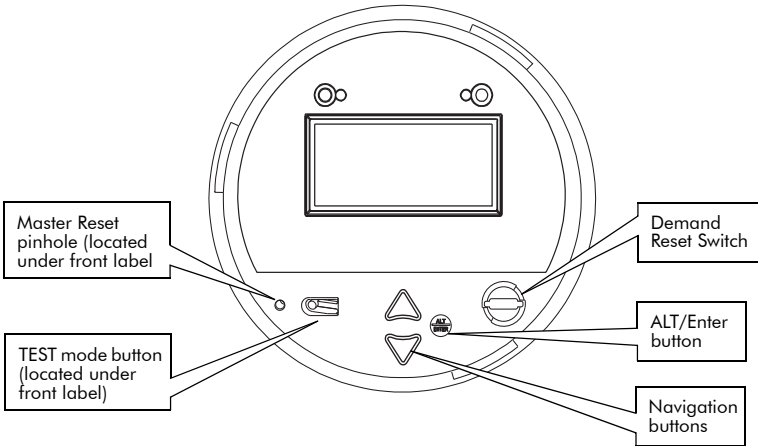

**DEMAND RESET SWITCH:** Resets the peak demand values logged in the meter. Can be activated with the cover on or off.



**ALT/ENTER BUTTON:** Toggles between NORM and ALT display modes. Hold for 3 seconds to access Setup menu.



**MASTER RESET BUTTON:** Recessed to prevent accidental activation. You must remove the meter cover and its label to access.



**TEST MODE BUTTON:** Places the meter into TEST mode, ceasing accumulation of billable quantities.



**NAVIGATION BUTTONS:** Press the UP/DOWN buttons to highlight menu items, or increment/decrement numbers.

# Meter Labels

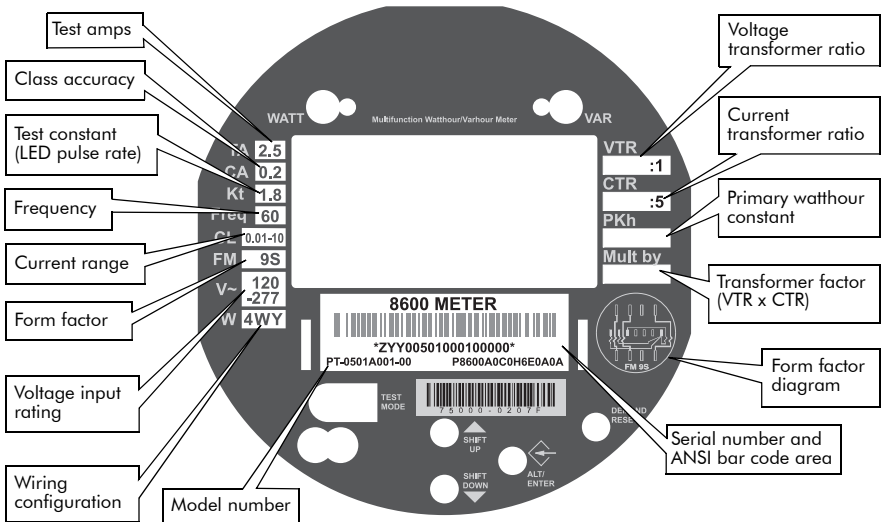

## Model Number Verification

Check the model number on your meter's label and make sure it matches the model number on your purchase order or sales order slip.

# Before You Begin

Familiarize yourself with the steps in this guide and read the safety precautions presented in "Installation Considerations" on page 3.

## Recommended Tools

- ◆ #1 and #2 Phillips screwdrivers
- ◆ Precision flat-head screwdriver
- ◆ Wire cutters / stripper

## Socket Meter Dimensions

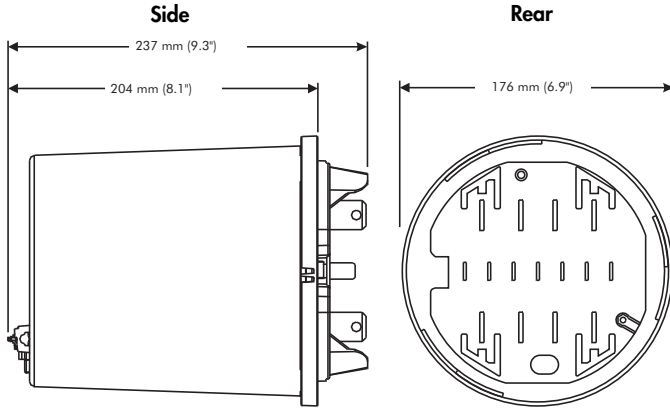

## Switchboard Meter Dimensions

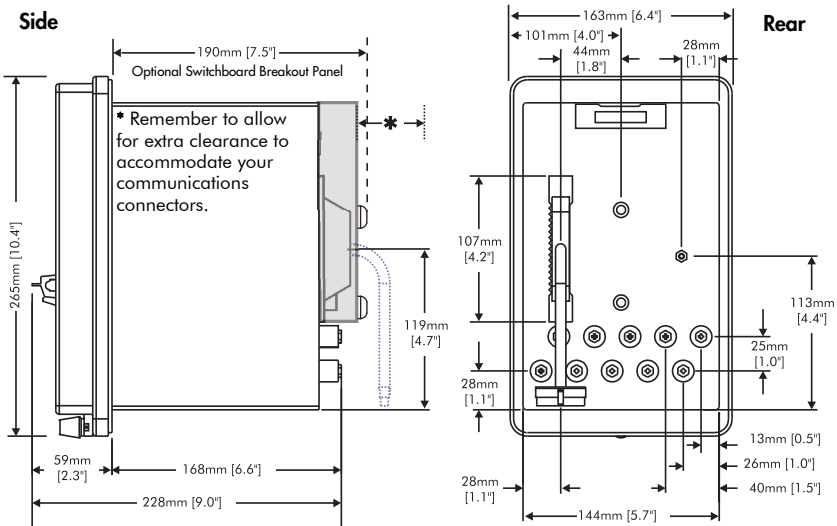

# Step 1: Mount the Meter

Review the steps in this section before installing the meter and determine the types of revenue sealing devices that you want to use before installing the meter. Examine the meter's label to verify its service type matches your intended application.

## DANGER

The meter chassis ground must have an adequate low impedance connection to the protective earth ground before the device is powered and must have fuses (customer supplied) in all voltage input and auxiliary (control) power circuits.

Failure to follow these instructions will result in death or serious injury.

## NOTE

Include a switch or circuit breaker (customer supplied) in the installation in close proximity to the unit and within easy reach of the operator. Mark it as the disconnecting device for the unit.

### Environmental Considerations

<b>Mounting Location</b>	Indoor use
<b>Pollution Degree</b>	2
<b>Altitude</b>	Less than 2000 m (6561 feet) above sea level
<b>Operating Range</b>	-40 to 85°C (-40 to 185°F)
<b>Display Operating Temperature</b>	-20 to 60°C (-4 to 140°F)
<b>Humidity</b>	5% to 95% non-condensing humidity

## Socket Meter Mounting

1. For **pre-installed sockets**: inspect and clean the ground contacts. Remove any paint, rust or other contamination preventing proper electrical connection of the meter ground tab (terminal); verify that the socket base ground contacts (terminals) are connected to the protective earth ground. For **new installations**: use only sockets with ground contacts. Ensure proper connection of the socket ground contacts to the protective earth ground.  
See "Step 2: Wire the Ground Terminal" on page 12 for details.

2. If required, attach an anti-tamper seal through the outer cover of the meter to seal the outer casing to the backplate.

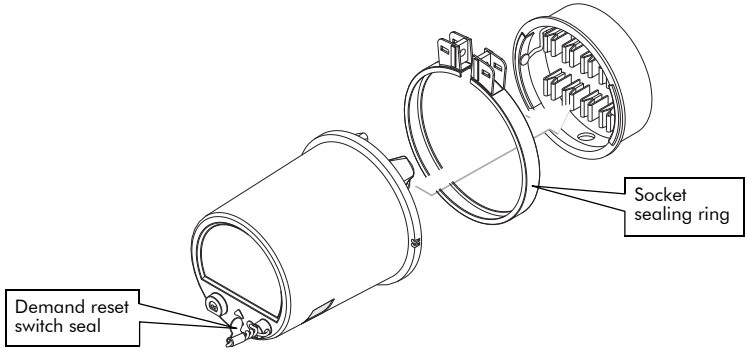

3. Align the meter so that the meter ground tab (terminal) will contact the socket base ground contacts.
  4. Feed any I/O and communications wiring through the socket’s opening from the back of the unit. If your socket is the “OPEN” type, hold the wiring to the side of the meter before pushing it firmly into the socket.
  5. Verify the protective earth ground connection.
  6. If required, attach the socket sealing ring and seal the Demand Reset switch.
- For more information on meter sealing features, see the meter’s User Guide.

## Switchboard Meter Mounting

1. Prepare a mounting hole for the switchboard case.

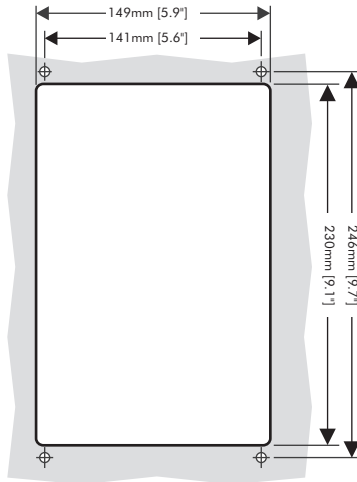

2. Place the switchboard case into the prepared mounting hole. Attach the case using the four mounting screws, washers and nuts. Insert the meter into the switchboard case and move levers into the locked position.

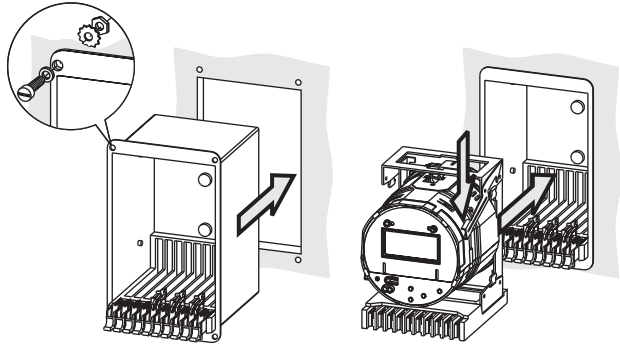

3. Verify the protective earth ground connection.
4. Place the case cover into position and tighten the thumbscrew.

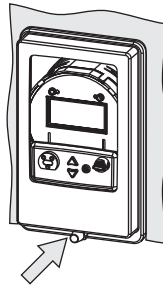

5. Apply anti-tamper sealing if required.  
For more information on meter sealing features, see the meter's User Guide.

# Step 2: Wire the Ground Terminal

**⚠ DANGER**

The meter chassis ground must have an adequate low impedance connection to the protective earth ground before the device is powered and must have fuses (customer supplied) in all voltage input and auxiliary (control) power circuits.

Failure to follow these instructions will result in death or serious injury.

Meter Type	Chassis Ground Connection	Wire Size
Socket	Contact to a clean, unpainted earth grounded surface on the socket front flange.	AWG 12 (3.31 mm <sup>2</sup> )
Switchboard	Ground terminal on the rear of the meter.	AWG 14 (2.5 mm <sup>2</sup> )

### Socket Meter Ground Connection

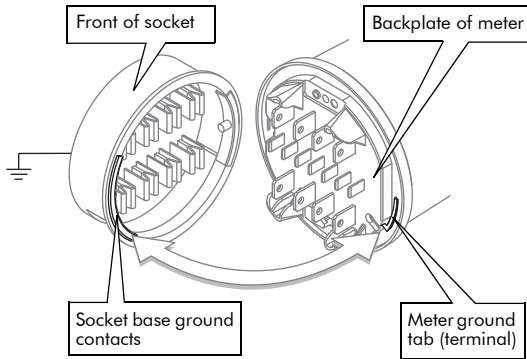

### Switchboard Meter Ground Connection

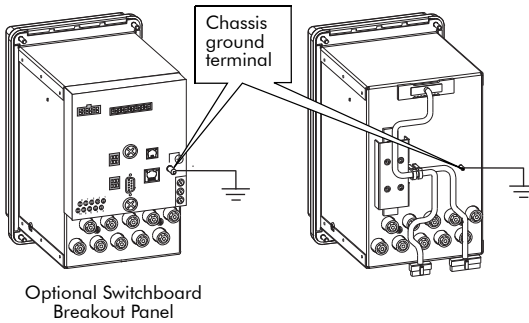

## Verify the ground connection

### Socket Meters

Verify that the meter ground tab (terminal) is properly connected (bonded) to the protective earth ground.

### Switchboard Meters

Verify that the meter metal frame is properly connected (bonded) to the protective earth ground.

## Step 3: Wire the Onboard I/O (optional)

### DANGER

Do not use the meter outputs for primary protection functions. These include applications where the devices perform energy limiting functions or provide protection of people from injury. Failure to follow these instructions will result in death or serious injury.

Meters ordered with onboard I/O include a cable with a female connector that attaches to the 16 pin male connector on the meter cable, and 16 bare-ended wires that connect to the digital input and output devices.

Additional I/O functionality for ION8600 meters is provided by the PowerLogic I/O Expander device (ordered separately). For more information, see the *I/O Expander Installation Guide*.

### I/O Cable Pin Assignments (all meters)

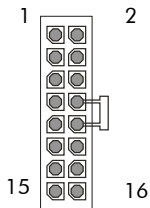

Pin	Wire Colors	Function
1	Black	Output C1 K (Common)
2	White	C1 Z (NC)
3	Red	C2 Z (NC)
4	Green	C1 Y (NO)
5	Orange	C2 Y (NO)
6	Blue	C2 K (Common)
7	White wire / Black marking	C3 K (Common)
8	Red wire / Black marking	C3 Z (NC)
9	Green wire / Black marking	C4 Z (NC)
10	Orange wire / Black marking	C3 Y (NO)
11	Blue wire / Black marking	C4 Y (NO)
12	Black wire / White marking	C4 K (Common)
13	Red wire / White marking	Input S2
14	Green wire / White marking	S1
15	Blue wire / White marking	SCOM
16	Black wire / Red marking	S3

The transient suppression device shown in the following connection diagrams must meet the following specifications:

Polarization	Bidirectional
Breakdown Voltage	300 V maximum
Peak Power Dissipation	<ul style="list-style-type: none"> <li>◆ 10 kW for 10 microseconds (minimum)</li> <li>◆ 1.5 kW for 1 millisecond (minimum)</li> </ul>

# Form C Digital Outputs

## Digital Output Specifications

Type	Form C solid state outputs (4) C1, C2, C3, C4 supported through meter
Wire	1.3 to 0.1 mm <sup>2</sup> (16 to 28 AWG)
Max Load Voltage	130 VAC / 200 VDC
Max Load Current	100 mA
ON Resistance	30 Ω typical, 50 Ω maximum
OFF Resistance	400 MΩ minimum
Isolation	2000 V rms, 60 Hz for 1 minute (to ground) 1000 V rms, 60 Hz for 1 minute (between outputs)
Rated Impulse Voltage	2500 V peak (to ground) 1500 V peak (between inputs or outputs) (CAT II)
Update Rate	20 ms (accuracy = +/- 7 ms), not including communication lag time. State changes occur within 20 ms. 1/2 cycle for internal I/O
Signal Type	Continuous or pulse
Fusing	Protect with 100 mA slow-blow fuse such as Littlefuse 201 Series 100 mA fuse.
Max Output Transition	50 per second
Lifetime	No load = 10,000,000 operations Rated voltage and load = 100,000 operations
Minimum Pulse Width	1 ms
Timing resolution	1/2 cycle or 1 s

## Typical Form C Digital Output Connections

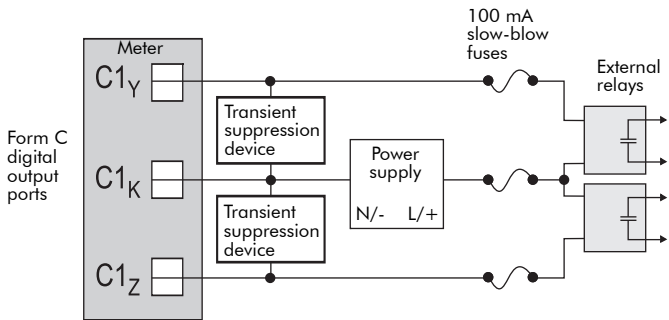

## Form A Digital Inputs

The meter's digital inputs can be self-excited or externally excited (using a customer-supplied power supply). External excitation requires disabling the meter's internal excitation (default setting) by removing the meter's cover and moving jumpers on connector pins. See "Setting Jumper for External Digital Input Excitation" on page 16 for details.

### Digital Input Specifications

Type	Form A input (1) Self-excited (internal 30 VDC supply) (external 24 to 130 VDC)
Wire	Use wiring appropriate for the application
Max Load Voltage	30 VDC internal (supplied) 130 VDC external
Max. Load Current	100 mA
Isolation	2000 V rms, 60 Hz for 1 minute (to ground) 1000 V rms, 60 Hz for 1 minute (between outputs)
Rated Impulse Voltage	2500 V peak (to ground) 1500 V peak (between inputs or outputs) (CAT II)
Min. Pulse Width	20 ms
Max. Input Transition Rate	50 per second
Scan Time	20 ms
Timing Resolution	1 ms, with 2 ms accuracy
Inputs	ON for external resistance of 2 k $\Omega$ or less OFF for external resistance of 4 M $\Omega$ or greater

### Typical Form A Digital Input Connections - Internal Excitation

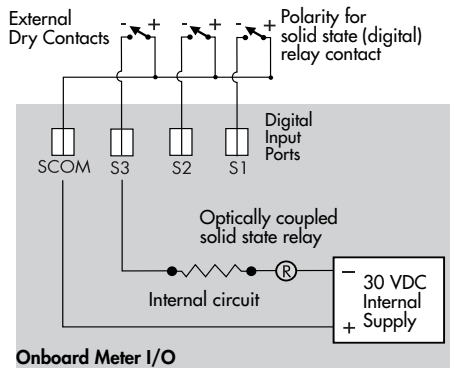

### Typical Form A Digital Input Connections - External Excitation

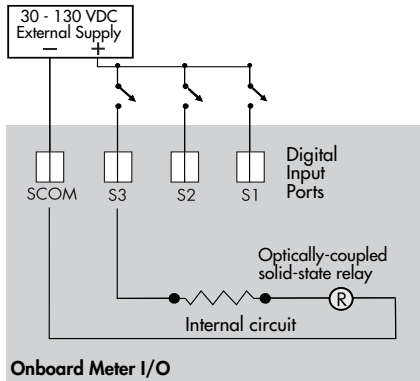

### Setting Jumper for External Digital Input Excitation

#### CAUTION

Components inside the meter are extremely sensitive to electrostatic discharge. Use anti-static precautions when working inside the unit. Failure to follow these instructions can result in damage to the meter and will void the meter's warranty.

1. Ensure power supply to meter is not connected.
2. Remove any anti-tamper sealing devices located at meter's base.
3. Rotate plastic cover 1/4 turn counter-clockwise and pull cover off.

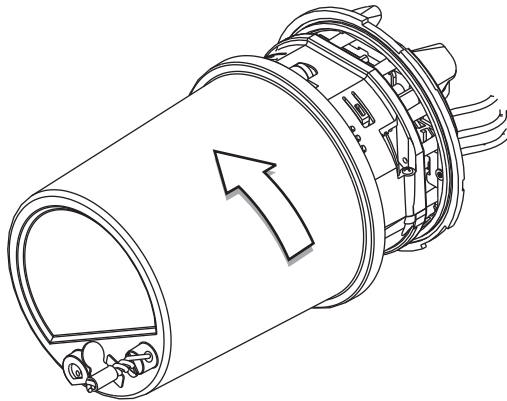

4. Use a #1 Phillips screwdriver to remove the two screws and washers on the top of the meter that hold on the silver EMI shield.
5. Carefully remove the EMI shield by pulling it towards the meter front.
6. The excitation pins and jumpers are in a recessed cavity on the bottom left of the meter.

Remove both jumpers and place one jumper on pins 2 and 3 of the four-pin header (as shown below). Keep the second jumper for future use.

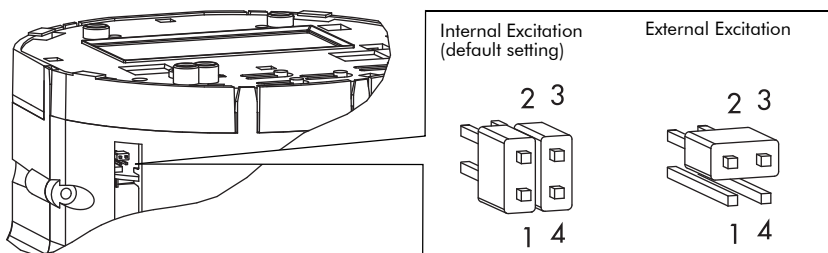

7. Replace the EMI shield and re-attach with the two screws and washers. Do not overtighten.
8. Replace the plastic cover and any anti-tamper sealing.  
Onboard digital input internal excitation is now disabled; an external supply can be used for external contacts.

#### Onboard I/O Precautions

State change latency .....20 ms (digital output)

40 ms (digital input modules)

Control schemes .....Use intermediate mechanisms so relay control can be disabled for servicing.

## Step 4: Wire the Voltage and Current Inputs

### DANGER

The meter chassis ground must have an adequate low impedance connection to the protective earth ground before the device is powered and must have fuses (customer supplied) in all voltage input and auxiliary (control) power circuits.

Failure to follow these instructions will result in death or serious injury.

### Voltage Inputs Fusing

Install 2 A slow-blow fuses (customer supplied) in the voltage measurement input circuits as shown in the following installation wiring diagrams. Power supply connections (auxiliary only) must also be fused. See "Step 6: Wire the Power Supply" on page 31 for details.

### NOTE

All fuses in the following wiring diagrams are **customer supplied**; they are not provided with the meter.

**The maximum rated voltage for meter voltage measurement terminals is 277 VLN/480 VLL.**

# Form 9 and 9S (3 element)

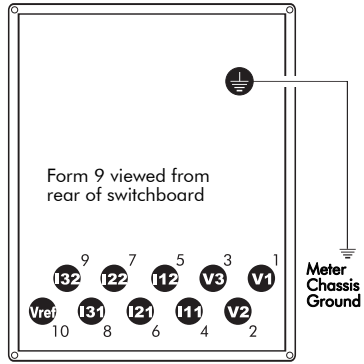
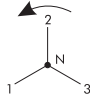
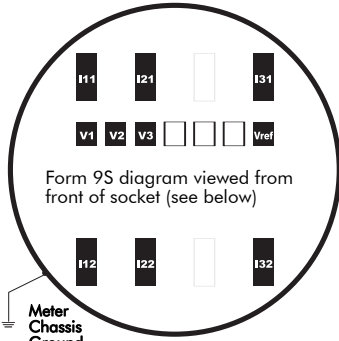

Front of socket (wiring view)

Back of meter

VOLTS MODE = 9S-4 Wire Wye/Delta  
120 V L-N

See "Phasor Diagrams" on page 37 to verify meter operation.

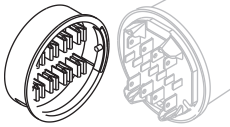

## Form 9 and 9S, 4-Wire Wye, no PTs, 3 CTs

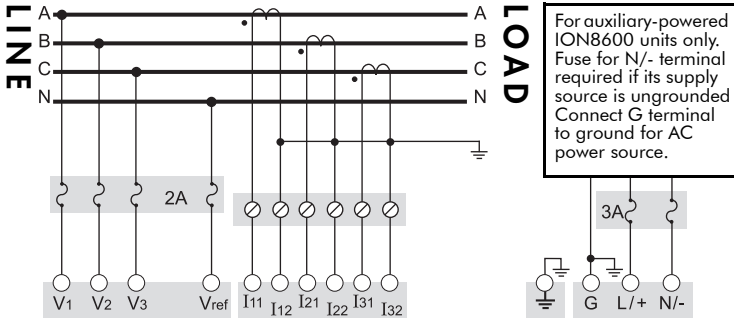

## Form 9 and 9S 4-Wire Wye, 3 PTs, 3 CTs

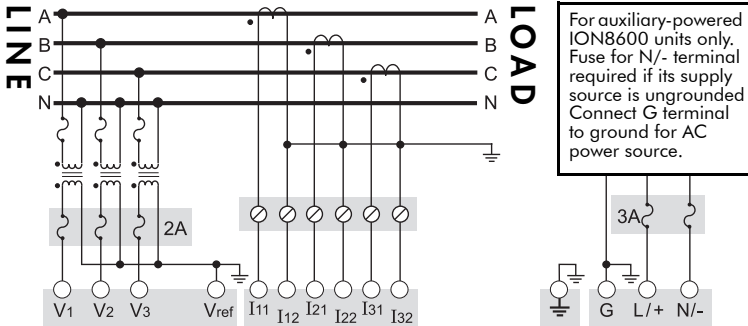

### Form 9 and 9S, 3-Wire Wye, 3 PTs, 3 CTs

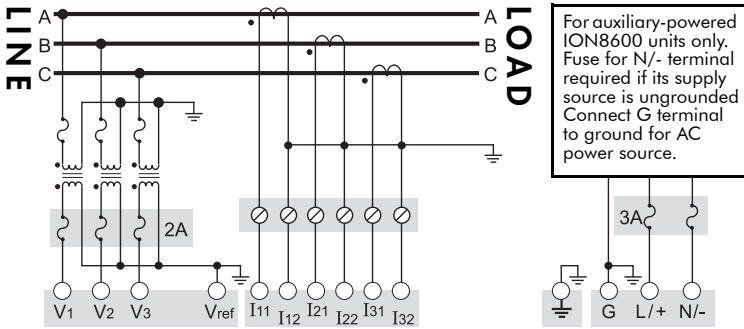

### Form 9 and 9S, 3-Wire Wye, 3 PTs, 2 CTs

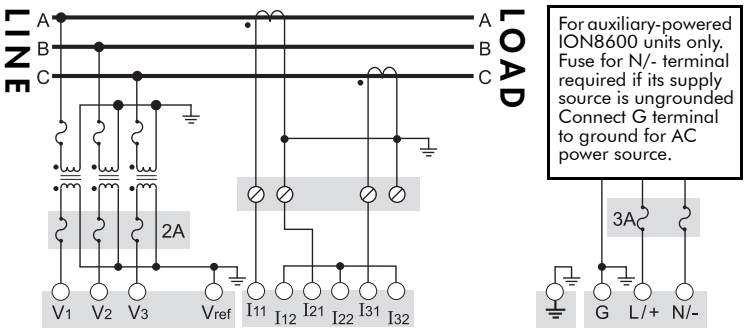

### Form 9 and 9S 4-Wire Delta, no PTs, 3 CTs (Red/High Leg Delta)

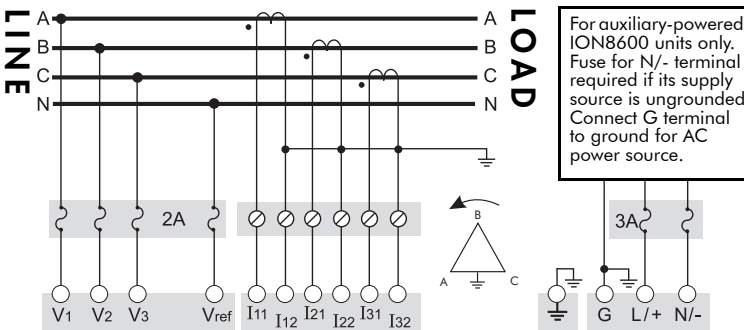

### ⚠ CAUTION

**BEFORE** performing an installation using the above Form 9 or 9S, 4-Wire Delta wiring configuration, see the *Red/High Leg Delta* technical note (available for download from the PowerLogic website) for important details.

# Form 35 and 35S (2-element)

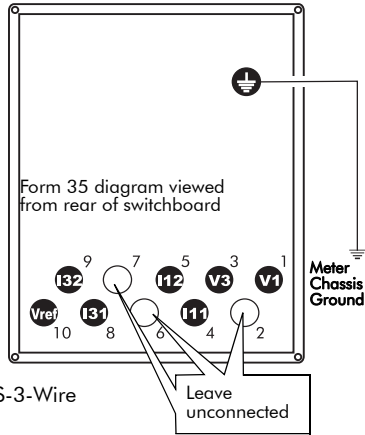
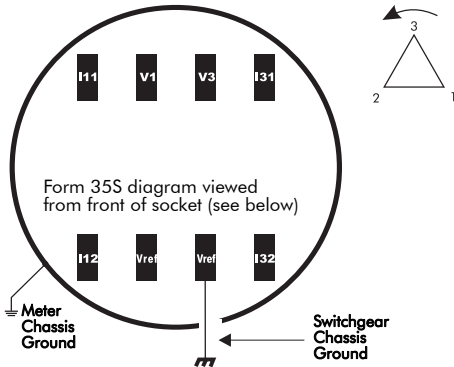

Front of socket (wiring view)

Back of meter

VOLTS MODE = 35S-3-Wire  
120 - 480 V L-L

See "Phasor Diagrams" on page 37 to verify meter operation.

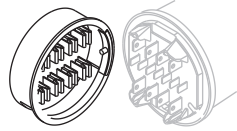

## Form 35 and 35S 3-Wire Delta, 2 PTs, 2 CTs

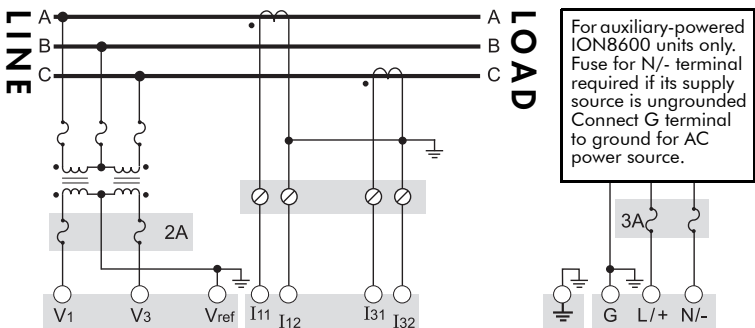

## Form 35 and 35S, 4-Wire Wye, 2 PTs, 3 CTs\*

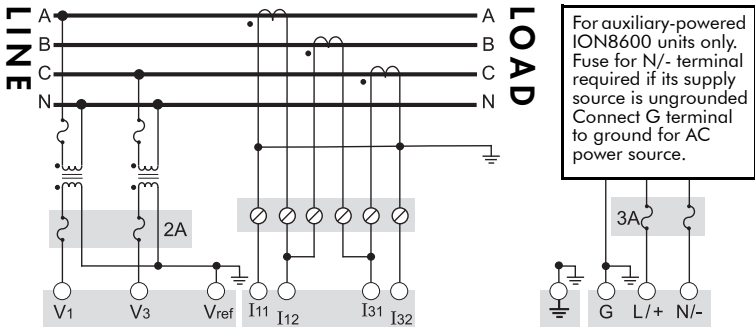

\* This configuration can affect some of the meter's parameter calculations. Contact Schneider Electric for details.

## Form 35 and 35S, 3-Wire Delta, No PTs, 2 CTs

### CAUTION

The pinout silhouette below is specific to **Form 35 and 35S, 3-Wire Delta, No PTs, 2 CTs**. Ensure Vref is **not** connected to ground.

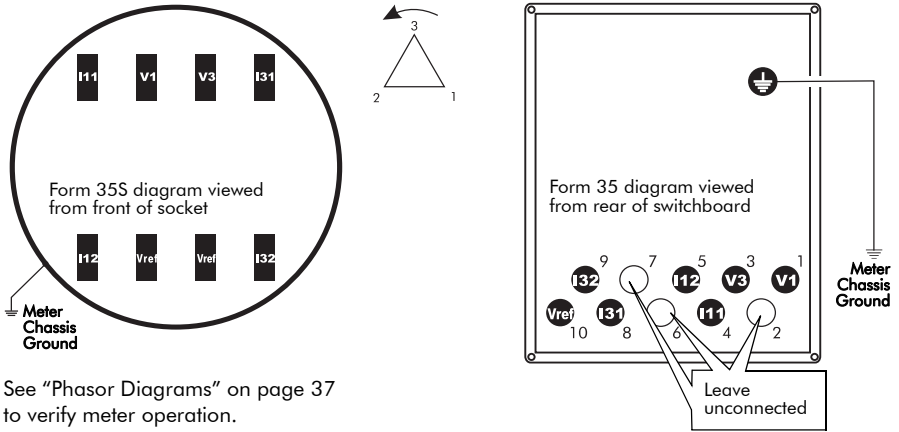

See "Phasor Diagrams" on page 37 to verify meter operation.

VOLTS MODE = 35S-3-Wire  
120 - 480 V L-L

### NOTE

This configuration can be used without PTs **provided voltage specifications are within the acceptable range**. Acceptable values differ for blade powered and auxiliary powered meters. See "Step 6: Wire the Power Supply" on page 31 for these values.

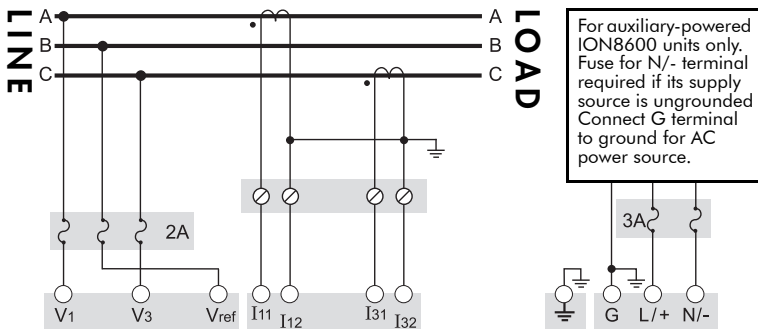

# Form 36 and 36S (2½-element)

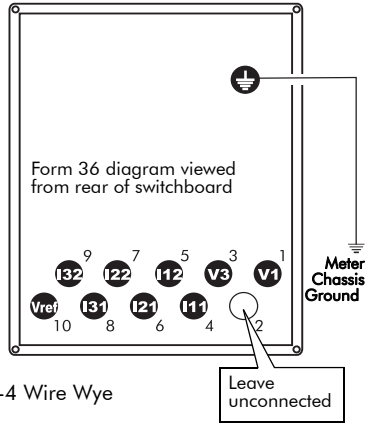
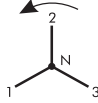
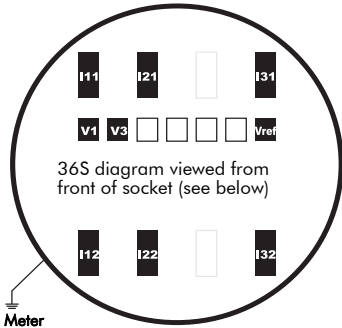

Front of socket (wiring view)

Back of meter

VOLTS MODE = 36S-4 Wire Wye  
57 - 277 V L-N

See "Phasor Diagrams" on page 37 to verify meter operation.

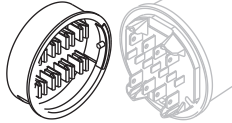

## Form 36 and 36S, 4-Wire Wye, no PTs, 3 CTs

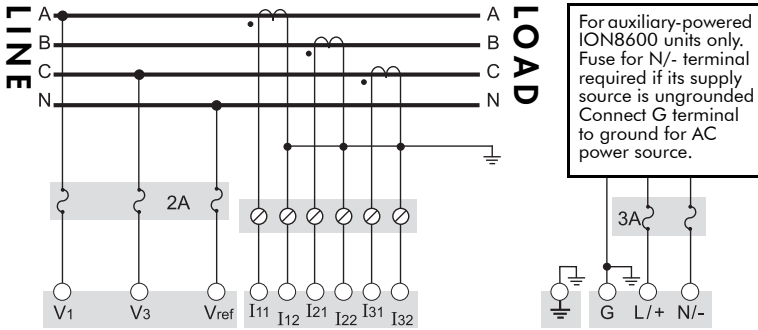

## Form 36 and 36S 4-Wire Wye, 2 PTs, 3 CTs

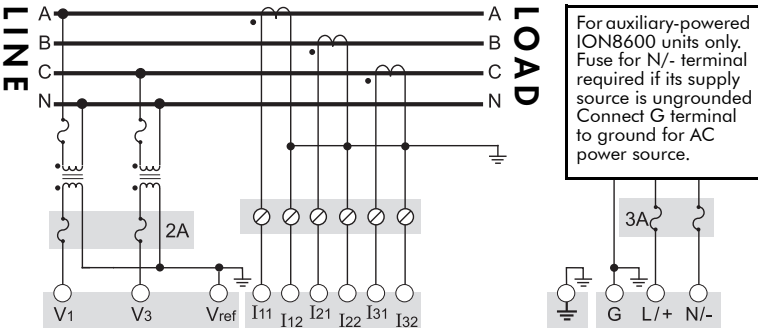

# Form 39S (3 element; I4 optional)

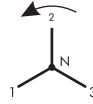
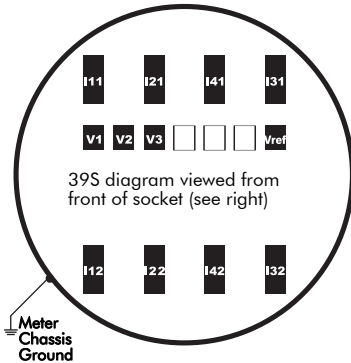

See "Phasor Diagrams" on page 37 to verify meter operation.

Front of socket (wiring view)      Back of meter

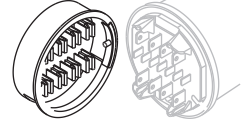

VOLTS MODE = 9S 4 Wire Wye/Delta  
57 - 277 V L-N

I4 optional input for ION8600A / ION8600B meters only

## Form 39S 4-Wire Wye, no PTs, 4 CTs

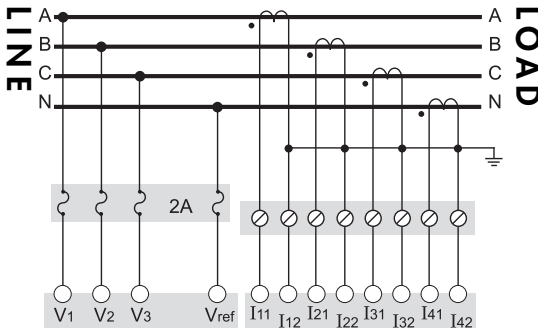

For auxiliary-powered ION8600 units only. Fuse for N/- terminal required if its supply source is ungrounded. Connect G terminal to ground for AC power source.

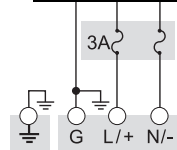

## Form 39S 4-Wire Wye, 3 PTs, 4 CTs

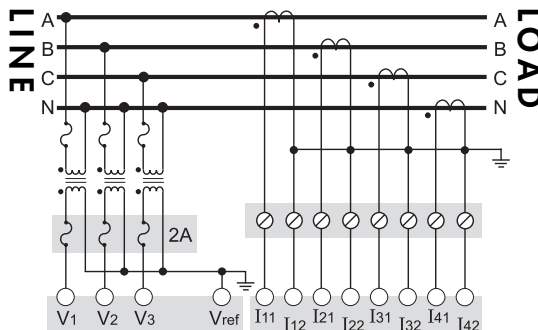

For auxiliary-powered ION8600 units only. Fuse for N/- terminal required if its supply source is ungrounded. Connect G terminal to ground for AC power source.

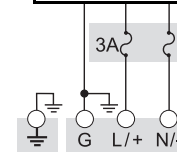

VOLTS MODE = 9S 4 Wire Wye/Delta

I4 optional input for ION8600A / ION8600B meters only.

# Form 76S

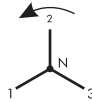
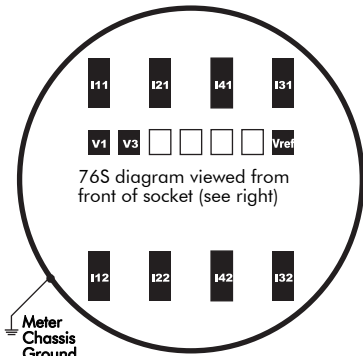

See "Phasor Diagrams" on page 37 to verify meter operation.

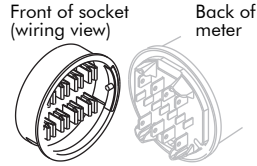

VOLTS MODE = 36S 4 Wire Wye

57 - 277 V L-N

14 optional input for ION8600A / ION8600B meters only

## Form 76S 4-Wire Wye, 2 PTs, 4 CTs

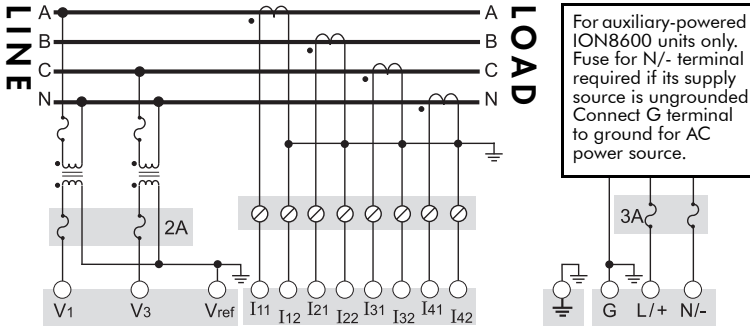

### NOTE

Set up for Volts Mode is included with each wiring diagram. Refer to "Step 8: Set Up Meter Using the Front Panel" on page 33 to learn how to set up Volts Mode on the meter.

## Voltage Inputs

Inputs (9S/39S)	Va, Vb, Vc, Vref
(35S)	Vab, Vcb, Vref
(36S/76S)	Va, Vc, Vref
Connector type (switchboard only)	Ring or split ring connector
Terminal screw torque rating (switchboard only)	2.82 Nm (25 in-lbs) max.
Recommended wire gauge	2.1 to 3.3 mm <sup>2</sup> (14 to 12 AWG)
Steady state (9S/36S/39S/76S)	Standard 57-277 (+/-15%) VLN rms <sup>1</sup>
Overload (9S/36S/39S/76S)	120 - 277 (+/-20%) VLN rms (standard) for 6 hours max <sup>1</sup> 57.7 - 69.3 (+/- 20%) VLN rms (low voltage) for 6 hours max <sup>1</sup>
Steady state (35S)	120 - 480 (+/-15%) VLL rms <sup>1</sup>
Overload (35S)	120 - 480 (+/- 20%) VLL rms for 6 hours max <sup>1</sup>
Dielectric withstand	2500 Vrms, 60 Hz for 60 s
Rated impulse voltage	6 kV peak (1.2/50 $\mu$ s) voltage surge L-L and L-GND (CAT III)
Input impedance	5M $\Omega$ per phase (phase-Vref)

<sup>1</sup> Specifications are limited by the operating range of the power supply if a non-auxiliary power supply is used.

## Current Inputs: Low Current (1A) Option

Inputs	Ia, Ib, Ic, (I neutral - 39S/76S only)
Connector type (switchboard only)	Ring or split ring connector
Terminal screw torque rating (switchboard only)	2.82 Nm (25 in-lbs) max.
Recommended wire gauge	2.1 to 3.3 mm <sup>2</sup> (14 to 12 AWG)
Starting current	0.001 A RMS
Input rating	1/10 A RMS (In= 1 A or 2 A, I <sub>max</sub> =10 A)
Overload	200 A RMS for 1 s, non-recurring
Dielectric withstand	2500 Vrms, 60 Hz for 60 s
Max. voltage	600 V RMS
Rated impulse voltage	6 kV peak (1.2/50 $\mu$ s) voltage surge L-L and L-GND Common and Transverse modes (CAT III)
Burden	0.05 VA per phase at 1 A (switchboard)

**Current Inputs: Standard (5A)**

Inputs	Ia, Ib, Ic, I neutral (39S/76S only)
Connector type (switchboard only)	Ring or split ring connector
Terminal screw torque rating (switchboard only)	2.82 Nm (25 in-lbs) max.
Recommended wire gauge	2.1 to 3.3 mm <sup>2</sup> (14 to 12 AWG)
Starting current	0.005 A RMS (In=1 A; I <sub>max</sub> =20 A)
Overrange	to 50A RMS
Input rating	0.05/20A RMS
Overload	500 A RMS for 1 s, non-recurring
Dielectric withstand	2500 Vrms, 60 Hz for 60 s
Max. voltage	600 V RMS
Rated impulse voltage	6 kV peak (1.2/50 $\mu$ s) voltage surge L-L and L-GND Common and Transverse modes (CAT III)
Burden	0.20 VA per phase at 5 A (switchboard) 0.05 VA per phase at 5 A (socket)

**Using Potential Transformers**

System Mode	Voltage Range	Requires PTs
<b>Wye</b>	120 VAC L-N or 208 VAC L-L	no
	277 VAC L-N or 480 VAC L-L	no
	347 VAC L-N or 600 VAC L-L	yes
	over 347 VAC L-N or 600 VAC L-L	yes
<b>Single Phase</b>	120 VAC L-N or 240 VAC L-L	no
	277 VAC L-N or 554 VAC L-L	no
	over 277 VAC L-N or 554 VAC L-L	yes
<b>Delta</b>	up to 480 VAC L-L	no <sup>1</sup>
	over 480 VAC L-L	yes

<sup>1</sup> See "Form 35 and 35S, 3-Wire Delta, No PTs, 2 CTs" on page 21 for details.

# Step 5: Wire the Communications

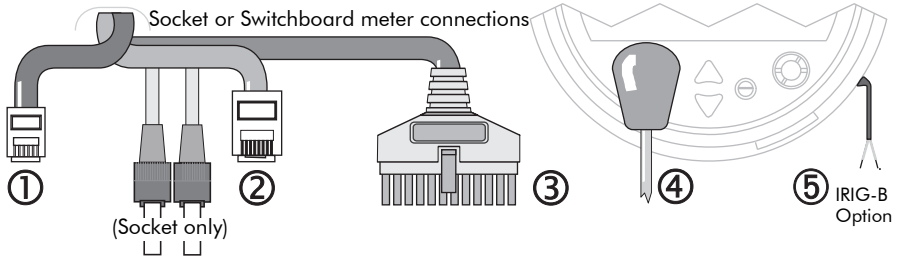

## ① Modem (optional)

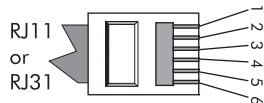

Modem RJ11 or RJ31 on COM2  
FCC part 68 telephone cord

### RJ11 (6 pin)

Pin 3 = Ring (RJ11)  
Pin 4 = Tip (RJ11)

### RJ31 (8 pin)

Pin 1 = Ring (out): connect to other device  
Pin 4 = Ring (in): from telephone co.  
Pin 5 = Tip (in): from telephone co.  
Pin 8 = Tip (out): connect to other device

## ② Ethernet-BaseT (optional)

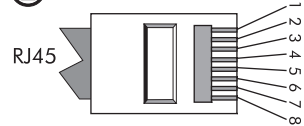

10Base-T (RJ45) Category 3 UTP (min.)

Pin 1 = Transmit Data +  
Pin 2 = Transmit Data -  
Pin 3 = Receive Data +  
Pin 6 = Receive Data -

### IP Service Ports:

ION = 7700  
Modbus RTU = 7701  
Modbus TCP = 502  
EtherGate COM1 = 7801  
EtherGate COM4 = 7802  
DNP/TCP = 20,000

## ③ Breakout Cable (optional)

### DB9 Serial Assignments

PIN	DCE	Description
1	--	Not connected
2	TXD	Transmit (out)
3	RXD	Receive (in)
4	--	Not connected
5	GND	Ground
6	DTR	Terminal Ready
7	CTS	Clear to send
8	RTS	Request to send
9	--	Not connected

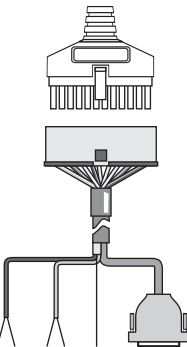

COM1: RS-232 or RS-485  
COM4: RS-485

### Pair 1 (COM1)

White = RS-485 COM1 Data +  
Black = RS-485 COM1 Data -

### Pair 2 (COM4)

Red = RS-485 COM4 Data +  
Black = RS-485 COM4 Data -  
Both pairs share shield

## ④

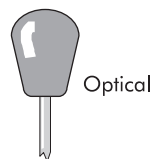

COM3: Optical Port, ANSI Type II  
Unit ID = 102  
BAUD default = 9600 bps  
RTS delay = 0.010 (interval)  
Default protocol = ION

## ② Ethernet-Fiber (optional)

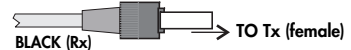
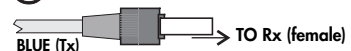

Wire = 62.5/125 multimode fiber optic  
Length = 68.6 mm (27 in)  
Connector type = ST (male)  
Max Length = 2000 m (6562 ft)  
Data Rate = 10 Mbps  
Isolation = Optical

**Attach male blue (Tx) to receive (Rx)**  
**Attach male black (Rx) to transmit (Tx)**

## ⑤ IRIG-B (optional)

Red = +      Black = -  
Wire = twisted pair  
22 AWG (0.33 mm<sup>2</sup>)  
Nom Voltage = 5 Vdc  
±10%  
Max Voltage = 8 Vdc

## Communications Cable Wire Cluster (switchboard meter)

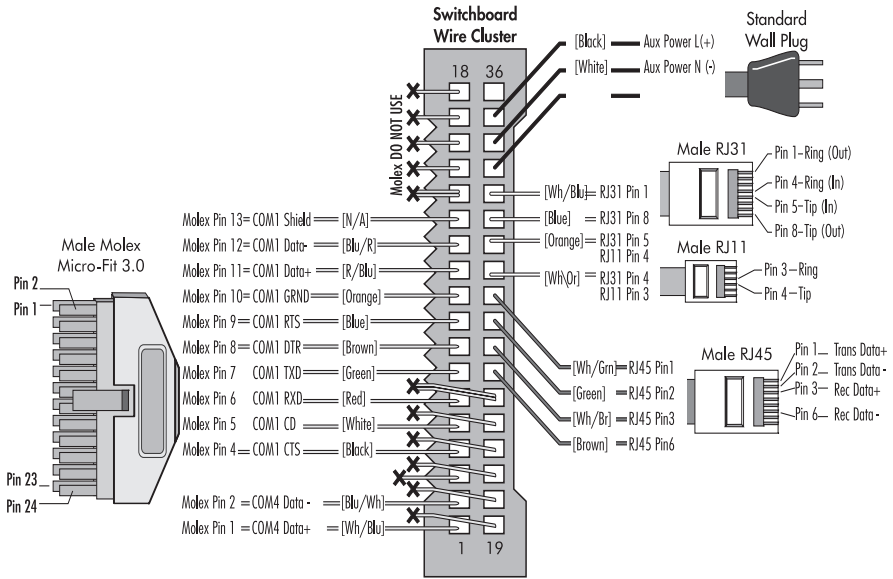

## Communications Cable Pin Assignments (all meters)

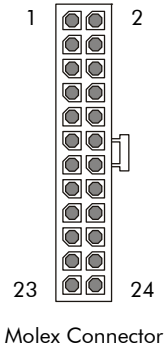

Pin	Wire Colors	Function
1	White/Blue	COM 4 Data+ or inactive
2	Blue/White	COM 4 Data- or inactive
3	Black/Blue	For I/O Expander—Do not Use
4	Black	COM 1 RS-232 CTS
5	White	COM 1 RS-232 CD
6	Red	COM 1 RS-232 RXD
7	Green	COM 1 RS-232 TXD
8	Brown	COM 1 RS-232 DTR
9	Blue	COM 1 RS-232 RTS
10	Orange	COM 1 RS-232 Ground (isolated)
11	Red/Blue	COM 1 RS-485 Data+
12	Blue/Red	COM 1 RS-485 Data -
13	N/A	Common RS-485 Shield
14	Two wires: Black/Orange, Black/Green	N/A - Do not Use
15	White/Orange	
16	Orange/White	
17	White/Green	
18	Green/White	
19	White/Brown	
20	Brown/White	
21	White/Grey	
22	Grey/White	
23	Red/Blue	
24	Two wires: Red/Orange, Red/Green	

## Communications Options

The ION8600 meter can also be ordered with the IRIG-B communication option. For more information, see the *IRIG-B GPS Time Synchronization* technical note.

### NOTE

Not all communication options are available on all meter models. Your meter may not support all the options listed below.

Port	Available Options	Notes
COM1	RS-232 / RS-485	User selectable RS-232 or RS-485
COM2	Internal Modem RJ11 or	
	Internal Modem RJ31	
COM3	Optical Port	ANSI Type II optical port located at front of meter
COM4	RS-485	
Network	Ethernet RJ45 (10Base-T)	Ethernet Fiber is only available on socket meters, not switchboard.
	Ethernet Fiber <sup>1</sup> (10Base-FL)	

<sup>1</sup> Onboard I/O is not available with the Ethernet Fiber option.

## Optional Switchboard Breakout Panel

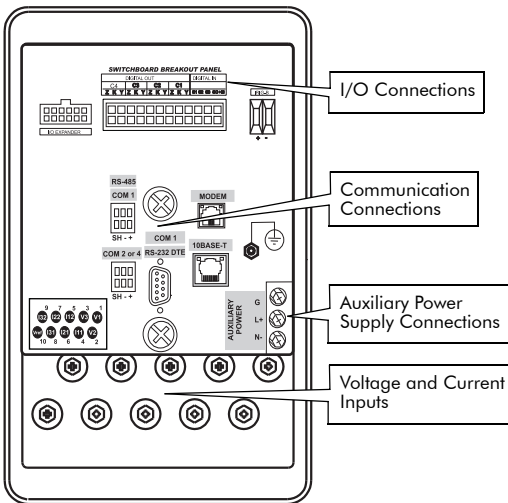

### Captured-Wire Connections

Use a small (0.4 x 2.5 mm or 0.02 x 0.1 inch) slot/flat-head screwdriver to open and close (release) the spring-loaded captured-wire connectors on the breakout panel.

Insert the screwdriver into the smaller hole of the terminal and push up to create access for the incoming wire. Insert the wire into the corresponding hole below and remove the screwdriver to clamp the spring on the wire.

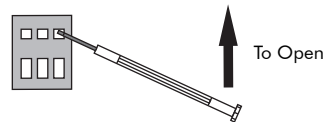

Connection	Available	Comments
RS-485	Yes	Captured wire connector
RS-232	Yes	DB9 connector
Internal Modem RJ11	Yes	RJ11 connector
Internal Modem RJ31	Yes	RJ31 connector
Ethernet RJ45	Yes	RJ45 connector
Ethernet Fiber	No	This option available only on socket meters
Onboard I/O	Yes	Captured wire connector (requires onboard I/O option)
IRIG-B	Yes	Captured wire connector (requires IRIG-B option)
Auxiliary Power	Yes	Terminal connectors (requires one of the Auxiliary Power options)
I/O Expander	Yes	Molex 14-pin female (requires separate I/O Expander device)

 **NOTE**

The COMs on an I/O Expander are not enabled when connected to a breakout panel. Use the RS-485 and RS-232 provided on the breakout panel.

**IRIG-B GPS Time Synchronization**

IRIG-B cannot be configured via the meter’s front panel. See the *IRIG-B GPS Time Synchronization* technical note for configuration procedures.

**RS-232 Connections**

The following graphic shows the connection options using the RS-232 cables.

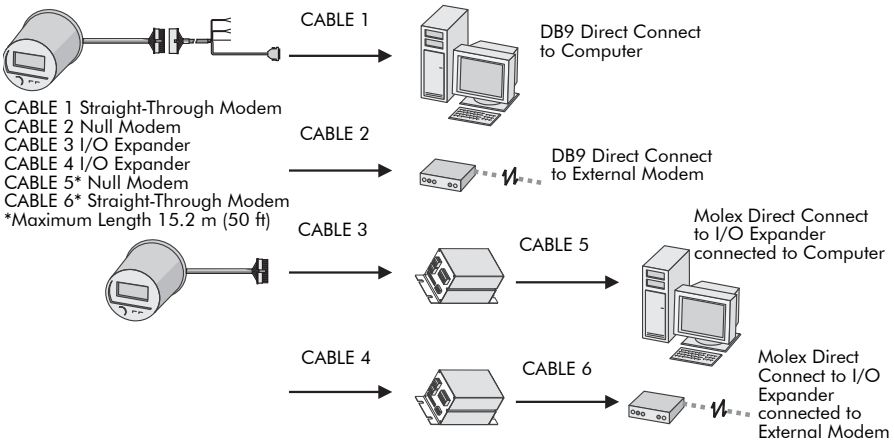

Use an RS-232 to RS-485 converter to connect multiple meter COM1 ports (selected as RS-485) to remote modem.

## Step 6: Wire the Power Supply

- ◆ For meters powered from voltage input connections, power is applied when the voltage inputs are energized.
- ◆ For externally-powered meters (power cord with grounded U-plug), plug in the connector to the appropriately-rated single-phase AC or DC power source.
- ◆ For switchboard breakout panel meters with auxiliary power supply, wire the terminal connectors to appropriately-rated single-phase AC or DC power source using a wire type and gauge appropriate for supply voltage.

### DANGER

The meter chassis ground must have an adequate low impedance connection to the protective earth ground before the device is powered and must have fuses (customer supplied) in all voltage input and auxiliary (control) power circuits.

Failure to follow these instructions will result in death or serious injury.

### Power supply fusing (auxiliary power supplies only)

Install 3 A slow-blow fuses (customer supplied) in the auxiliary (control) power circuits as shown in the wiring diagrams in "Step 4: Wire the Voltage and Current Inputs".

## Power Supply Specifications

Specification	Meter Powered from Voltage Inputs		Externally-powered Meter	
	Standard Power Supply	Standard Low Voltage Power Supply	Auxiliary Low Voltage Power Supply	Auxiliary High Voltage Power Supply
Rated inputs	<b>9S/39S, 36S/76S</b> 120-277 VLN RMS (-15/+20%) @ 47-63 Hz	57-70 VLN RMS (-15/+20%) @ 47-63 Hz	65-120 VLN RMS (±15%) @ 47-63 Hz 80-160 VDC (±20%)	160-277 VLN RMS (±20%) @ 47-63 Hz 200-350 VDC (±20%)
	<b>35S</b> 120-480 VLL RMS (-15/+20%) @ 47-63 Hz			
Rated impulse voltage	6 kV peak (1.2/50 uS) voltage surge L-L and L-GND Common and Transverse modes (CAT III)		4 kV peak (1.2/50 uS) voltage surge L-L and L-GND Common and Transverse modes (CAT II)	
Burden	6.8 VA/phase max. (5 VA/phase typical)		18.1 VA max. (12.5 VA typical)	20.3 VA max. (16.9 VA typical)
Minimum ride-through	100 ms 6 cycles @ 60 Hz at 96 VAC	100 ms 6 cycles @ 60 Hz at 46 VAC	100 ms 6 cycles @ 60 Hz at 46 VAC	100 ms 6 cycles @ 60 Hz at 96 VAC

# Step 7: Power Up the Meter

 **DANGER**

---

Before you apply power to the meter, ensure that the protective earth ground is securely connected and that the supply voltage is within the allowed range of the meter's power supply.

Failure to follow these instructions will result in death or serious injury.

---

1. Close the PT fuses (or direct voltage input fuses).
2. Open the CT shorting blocks.
3. Apply power to the meter.

# Step 8: Set Up Meter Using the Front Panel

Press and hold the **Alt/Enter** button for three (3) seconds to access Basic Setup. This example shows volts mode setup using the meter front panel.

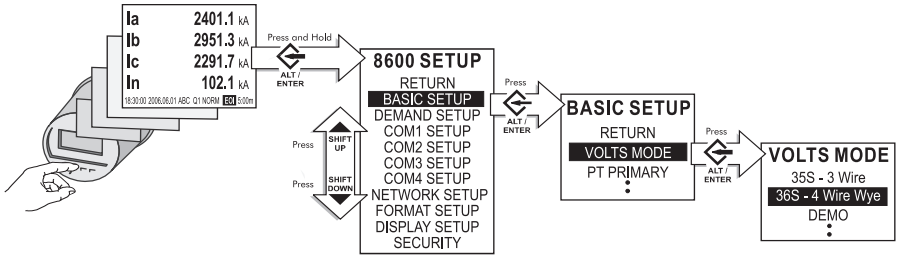

Set up the following:

Menu	Setting	Description	Range (Values)	Default
Basic Setup	Volts Mode	The power system's configuration – WYE, DELTA, etc.	9S- 4 Wire Wye/Delta 35S- 3 Wire 36S- 4 Wire Wye DEMO	9S- 4 Wire Wye/Delta
	PT Primary	The Potential Transformer's primary winding voltage rating	1.0 to 999,999.00	120
	PT Secondary	The Potential Transformer's secondary winding voltage rating	1.0 to 999,999.00	120
	CT Primary	The Current Transformer's primary winding current rating	1.0 to 999,999.00	5
	CT Secondary	The Current Transformer's secondary winding current rating	1.0 to 999,999.00	5
	I4 Primary	Primary rating for the I4 current transformer (if available)	1.0 to 999,999.00	5
	I4 Secondary	Secondary rating for the I4 current transformer (if available)	1.0 to 999,999.00	5
	VA Polarity	The polarity of the Potential Transformer on VA	Normal or Inverted	Normal
	VB Polarity	The polarity of the Potential Transformer on VB	Normal or Inverted	Normal
	VC Polarity	The polarity of the Potential Transformer on VC	Normal or Inverted	Normal
	IA Polarity	The polarity of the Current Transformer on IA	Normal or Inverted	Normal
	IB Polarity	The polarity of the Current Transformer on IB	Normal or Inverted	Normal
	IC Polarity	The polarity of the Current Transformer on IC	Normal or Inverted	Normal
	I4 Polarity	The polarity of the Current Transformer on I4	Normal or Inverted	Normal
Phase Rotation	Power system's phase rotation	ABC, ACB	ABC	

Menu	Setting	Description	Range (Values)	Default
<b>Demand Setup</b>	SWD Subinterval	Intervals used to compute your Sliding Window Demand values	1 to 5940	900
	SWD # Subintervals	The number of SWD periods in use	1 to 15	3
	SWD Pred Resp		0.00 to 99.00	70
	TD Interval <sup>1</sup>	Thermal demand period (seconds)	60 to 5940	N/A
	TD time const <sup>1</sup>	Thermal demand response rate	1.00 to 99.00	N/A
<b>COM1 Setup</b>	Protocol	Specifies which protocol is active	ION, Modbus RTU, Modbus Master, DNP v3.00, ModemGate, GPS: Truetime/Datum GPS: Arbiter GPS: Arbiter/Vorne Factory, EtherGate	ION
	Baud Rate	Specifies COM port baud rate during serial communications	300 to 115200	9600
	Transmit Delay	Specifies the meter's transmit delay setting	0 to 1.0	0.01
	Unit ID	Identifies the meter during serial communications	1 to 9999	From serial number <sup>2</sup>
	Serial Port	Parity and stop bits for the port	8O1, 8O2, 8N1, 8N2, 8E1, 8E2	8N1
	RS232 or RS485	Specifies RS-232 or RS-485	RS232, RS485	RS232
	RTS/CTS Handshake	Specifies if hardware flow control is used during RS-232 communication	RTS with delay, RTS/CTS	RTS with delay
<b>COM2 Setup</b>	Protocol	Specifies which protocol is active	ION, Modbus RTU, DNP v3.00, GPS: Truetime/Datum, GPS: Arbiter, GPS: Arbiter/Vorne, Factory	ION
	Baud Rate	Specifies COM port baud rate during serial communications	300 to 57600	9600
	Transmit Delay	Specifies the meter's transmit delay setting	0 to 1.0	0.01
	Unit ID	Identifies the meter during serial communications	1 to 9999	101
	Serial Port	Parity and stop bits for the port	8O1, 8O2, 8N1, 8N2, 8E1, 8E2	8N1
<b>COM3 Setup</b>	Protocol	Specifies the active communications protocol	ION, Modbus RTU, DNP v3.00, GPS: Truetime/Datum GPS: Arbiter GPS: Arbiter/Vorne Factory	ION
	Baud Rate	Specifies baud rate during serial communications	300 to 115200 <sup>3</sup>	9600
	Transmit Delay	Specifies the meter's transmit delay setting	0 to 1.0	0.01
	Unit ID	Identifies the meter during communications	1 to 9999	102
	Serial Port	Parity and stop bits for the port	8O1, 8O2, 8N1, 8N2, 8E1, 8E2	8N1

Menu	Setting	Description	Range (Values)	Default
COM4 Setup	Protocol	Specifies the active communications protocol	Same as COM1	ION
	Baud Rate	Specifies baud rate during serial communications	300 to 115200	9600
	Transmit Delay	Specifies the meter's transmit delay setting	0 to 1.0	0.01
	Unit ID	Identifies the meter during communications	1 to 9999	103
	Serial Port	Parity and stop bits for the port	8O1, 8O2, 8N1, 8N2, 8E1, 8E2	8N1
Network Setup	IP Address	Specifies TCP/IP Ethernet address	000.000.000.000 to 255.255.255.255	None
	Mask	Specifies Subnet Mask	000.000.000.000 to 255.255.255.255	None
	Gateway	Specifies Ethernet gateway (if used)	000.000.000.000 to 255.255.255.255	None
	SMTP Address	Specifies location of SMTP Server	000.000.000.000 to 255.255.255.255	None
	MAC Address	Machine Access Control address	hexadecimal	N/A <sup>4</sup>
Format Setup	Phase Labels	Specifies how phases are labelled	123, ABC, RST, XYZ, RYB, RWB	ABC
	PF Symbol	LD (leading)/LG (lagging)	CAP/IND, LD/LG, +/-	LD/LG
	Digit Group	Specifies symbols used to delimit thousands & decimal place holder	1000.0, 1 000.0, 1,000.0	1000.0
	Date Format	Specifies how dates are displayed	YYYY/MM/DD, MM/DD/YYYY, DD/MM/YYYY	MM/DD/YYYY
	Show DST	Specifies whether or not DST is displayed	Do not display DST, Display DST	Display DST
	Volts Decimal	Number of decimal places displayed for voltages	1.X to 123456789.XXX	1.XX
	Current Decimal	Number of decimal places displayed for currents	1.X to 123456789.XXX	1.XX
Display Setup	Power Decimal	Number of decimal places displayed for power values	1.X to 123456789.XXX	1.XX
	Update Rate	Sets when the display updates	1 to 6s (seconds)	1s
	Contrast	Higher numbers are sharper	0 to 9	6
	Backlight TO	How long the front panel display backlight stays on after the last button is pressed	0 to 7200 (seconds)	300
	DMD Lock TO	Minimum time allowed between consecutive demand resets	0 to 5184000 (seconds)	2160000
	Test Mode TO	How long the device remains in test mode before reverting to norm	60 to 21600 (seconds)	1800
	Display Scale	Scale applied to values before they are displayed	1.00 to 999999.0	1000
	Scaling Mode	Specifies if values are divided or multiplied by the Display Scale before being displayed	Multiply or Divide	Divide
Delta Vectors	Specifies how vector diagrams are displayed when in Delta mode	System or Instrument	Instrument	

Menu	Setting	Description	Range (Values)	Default
Security	Modify Passwd	Modifies standard password	0 - 999,999,999	0
	Disable Security	Disables meter security	Proceed	Enabled
	Web Config	Allows configuration through web server interface	Disabled, Enabled	Enabled

- <sup>1</sup> These settings are for legacy framework support only.
- <sup>2</sup> The factory set Unit ID for this port is based on the serial number of the meter. For example: Serial number: PABC-0009A263-10; Unit ID: 9263.
- <sup>3</sup> Optical port performance at baud rates higher than 19200 may not be supported by some optical probe models.
- <sup>4</sup> MAC address is factory set and is for reference only.

## Step 9: Verify Meter Operation

The LEDs on the side of the meter flash during communications.

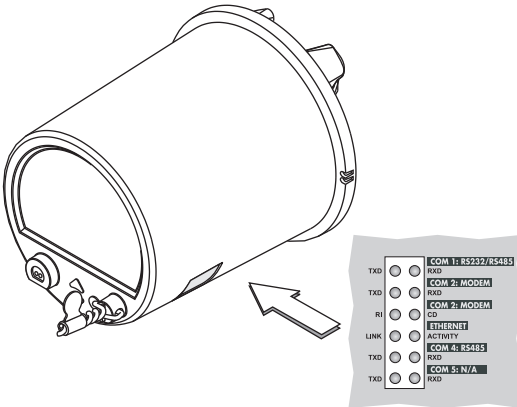

LED	Function
TXD / RXD	Flash = signals are being transmitted and received for serial ports
RI	Ring Indicator (flash = modem rings)
CD	Carrier Detect (on = active connection to modem)
LINK	On = active connection to 10 Base-T Ethernet port
ACTIVITY	Flash = signals are being transmitted and received for Ethernet 10 Base-T

## Phasor Diagrams

You can also view the ION8600's phasor diagram in real time. Use the Phasor Viewer available in ION Setup (free download from the website) to verify your meter's wiring. See the ION Setup online help for details.

### WYE - ABC Rotation

Applicable Volts Mode: 9S, 4W Wye/Delta and 36S, 4W Delta

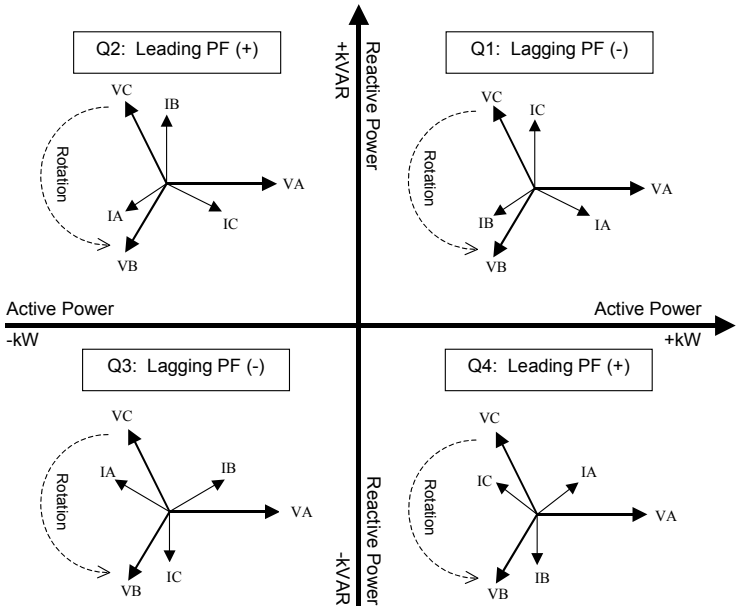

### WYE - ACB Rotation

Applicable Volts Mode = 9S 4W Wye/Delta and 36S 4W WYE

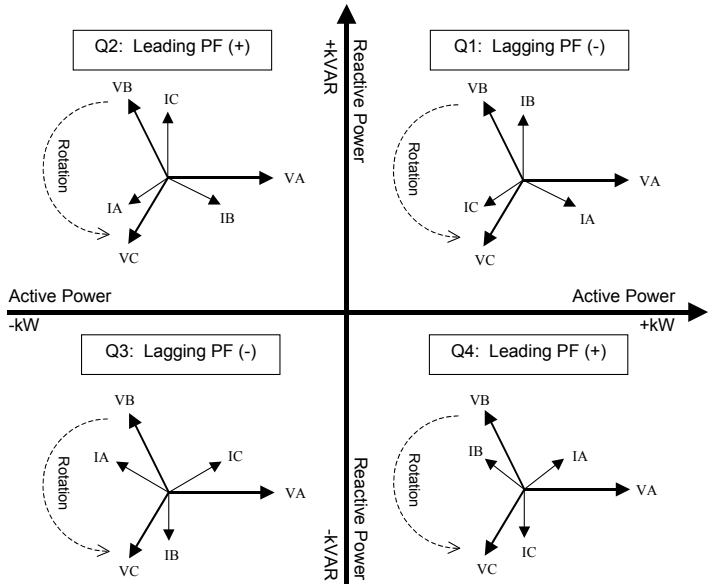

 **NOTE**

The following DELTA phasor diagrams are shown in Instrument mode.

### 3 Wire Delta - ABC Rotation

Applicable Volts Mode = 35S 3Wire

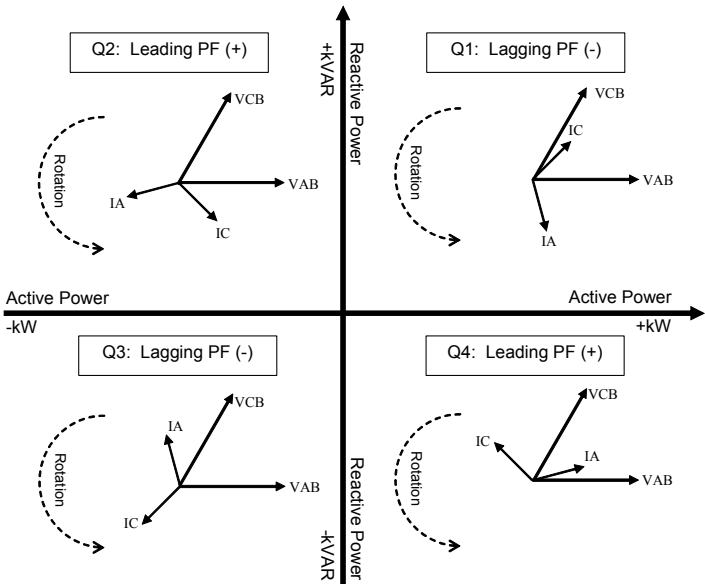

### 3 Wire Delta - ACB Rotation

Applicable Volts Mode = 35S 3-Wire

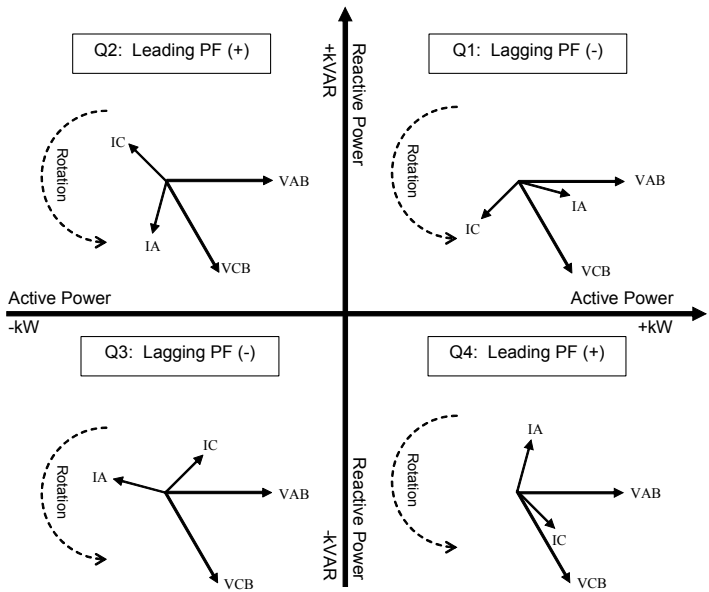

### 4 Wire Delta (High/Red Leg Delta)

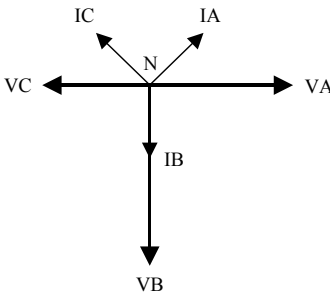

ION8600 Phasor diagram in 9S / 4WYE mode at UNITY PF.

Assuming 3PH phase load is dominant.

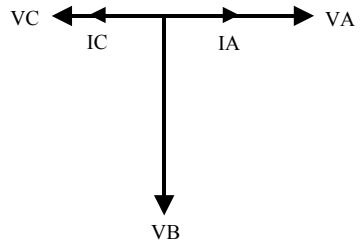

ION8600 Phasor diagram in 9S / 4WYE mode at UNITY PF.

3PH DELTA load is off. Only single phase load.

# Step 10: View Meter Data

## NORM mode

Use the **Up** and **Down** buttons to scroll through **NORM** mode display screens.

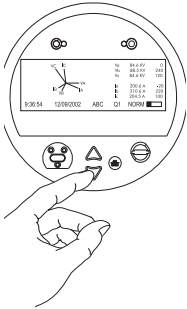

NORM Screen	Contents
kWh	kWh delivered/received
kVARh	kVARh delivered/received
kVAh	kVAh delivered/received
Peak Demand Delivered	Maximum delivered kW value (timestamped)
Peak Demand Received	Maximum received kW value (timestamped)
Peak Demand Reset	Number of Demand Resets (timestamped)
Q Metering	Approximated VARh measurements
Disk Simulator	Simulates mechanical watt-hour meter disk
All Segments	Black screen to indicate functioning display

## ALT mode

Press the **Alt/Enter** button once for **ALT** display modes. Press the **Up** or **Down** buttons to scroll through displays.

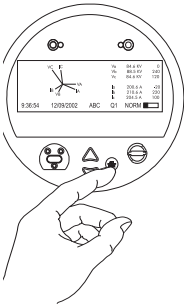

ALT Screen	Contents
Name Plate 1	Owner, firmware version, TAG 1 & 2
Name Plate 2	Sliding window settings
Event Log	Most recent high priority (255) events
Vector Diagram	Phasors and values for phase current/voltage
Instantaneous Voltage	Average voltage, L-N or L-L
Instantaneous Current	Phase current, average current
Instantaneous Power	kW total, kVAR total, kVA total, power factor
Instantaneous Demand	kW delivered/received
Voltage Harmonics (3 screens)	Per-phase voltage harmonic histograms
Current Harmonics (3 screens)	Per-phase current harmonic histograms
Instantaneous Demand	kW td delivered/received

<b>TOU Display Screens</b>	<b>Contents</b>
TOU Energy by Rate	kWh delivered values for each TOU rate
kW Peak Demand	Maximum kW delivered for each TOU rate
Previous Billing Energy	kWh delivered in PB
Prev Billing Peak Demand	Maximum kW delivered in PB
Previous Season Energy	kWh delivered for each TOU rate in PB
Prev Season Peak Demand	Max kW delivered for each TOU rate in PB
Prev Billing/Season Energy	kWh delivered/received in PB & billing season
Prev Bill/Season Pk Dem	Max kW sd received from PB & billing season
Prev Billing/Season Energy	kVARh del/rec in PB & billing season
Prev Bill/Season Pk Demand	kVAR del/rec in PB & billing season
Prev Billing/Season Energy	kVAh del/rec from PB & billing season
Pre Bill/Season Pk Demand	kVA del/rec in PB & billing season
Active TOU Rate	Active TOU billing rate
Active TOU Season	Active TOU billing season
Flicker	Flicker measurements from V1, V2 & V3
Frequency	Frequency information

 **NOTE**

PB = Previous Billing period.

### TEST Mode

<b>TEST Screen</b>	<b>Contents</b>
kWh Test	TEST mode kWh delivered/received
kVARh/KVAh Test	TEST mode kVARh/KVAh delivered/received
Instantaneous Demand Test	TEST mode kW delivered/received

### To Enter TEST Mode

<b>Meter Type</b>	<b>Method</b>
<b>Standard Meter (no hardware lock)</b>	Use ION software
	Remove outer cover and press TEST mode button (see "Meter Overview" on page 6)
<b>Hardware Locked Meter</b>	Remove outer cover and press TEST mode button (see "Meter Overview" on page 6)

 **NOTE**

The meter always returns to NORM mode after exiting TEST mode.





# PowerLogic™ ION8600

with WebMeter™

## Installation Guide

For further assistance  
please contact us at:

### Schneider Electric

Power Monitoring and Control  
2195 Keating Cross Road  
Saanichton, BC  
Canada V8M 2A5  
Tel: 1-250-652-7100

295 Tech Park Drive, Suite 100  
Lavergne, TN 37086  
USA  
Tel: 1-615-287-3400

Electropole (38 EQI)  
31, rue Pierre Mendès France  
F - 38050 Grenoble Cédex 9  
Tel : + 33 (0) 4 76 57 60 60

Getting technical support:  
Contact your local Schneider Electric sales  
representative for assistance or go to the  
[www.powerlogic.com](http://www.powerlogic.com) website.

ION, ION Enterprise, Modbus, Power Measurement,  
PowerLogic, Schneider Electric, Square D and WebMeter  
are either trademarks or registered trademarks of  
Schneider Electric in France, the USA and other countries.  
All other trademarks are property of their respective  
owners.

Electrical equipment should be installed, operated,  
serviced, and maintained only by qualified personnel.  
No responsibility is assumed by Schneider Electric for any  
consequences arising out of the use of this material.

70002-0266-12  
© 2009 Schneider Electric. All rights reserved.  
05/2009