

PowerLogic® ION7550/ION7650

Power and energy meters



Features

High visibility, multilingual, IEC/IEEE configureable display

Large, backlit LCD presents multiple simultaneous real-time and timestamped historical parameters as well as graphical trends and histograms.

High accuracy standards

Meets stringent IEC and ANSI measurement accuracy standards such as IEC 62053-22 Class 0.2S, ANSI C12.20 0.2 Class 10 & 20.

Digital fault recording

Simultaneously capture voltage and current channels for sub-cycle disturbance transients, as well as multi-cycle sags, swells and outages: 1024 samples/cycle waveform recording, 20/17 μ s transient capture (50/60 Hz).

Power quality analysis and compliance monitoring

A choice of THD metering, individual current and voltage harmonics readings, waveform capture, EN50160 and flicker (PowerLogic ION7650 only) power quality compliance evaluation, and voltage and current disturbance (sag/swell) detection.

Complete communications

Fiber - Ethernet - Serial - Modem. Gateway functionality simplifies communications architecture and reduces leased line or connection costs. Concurrent, independent ports communicate with protocols such as ION[®], DNP 3.0, Modbus[®] RTU, Modbus TCP, Modbus Master. 32 concurrent Modbus/TCP server connections. Dial-out capability when memory is near full. Data push capability through SMTP (email).

Patented ION[®] technology

Provides a modular, flexible architecture that offers extensive user programmability. Uniquely addresses complex monitoring and control applications. Adapts to changing needs, avoiding obsolescence.

Disturbance direction detection

Determine the location of a disturbance more quickly and accurately by determining the direction of the disturbance relative to the meter. Analysis results are captured in the event log, along with a timestamp and confidence level indicating level of certainty.

Alarm setpoint learning

Helps simplify alarming configurations by monitoring normal operating parameters and, over time, learning what constitutes a sag, swell, transient or high and low setpoint. Learning can be configured in either ION Setup or PowerLogic ION Enterprise software.

Trending and forecasting

Forecast values such as demand to better control demand charges and billing rates. View results via the meter's web pages. Analyse trends to support proactive maintenance schedules.

Transformer/line loss compensation

Automatically measure, compensate and correct for transformer or line losses when meter is physically separated from the point of billing or change of ownership.

Inputs and outputs

Digital and analog inputs and outputs for pulse counting, demand metering for other WAGES utilities, equipment status/position monitoring, demand synchronization, triggering conditional energy metering, equipment control or interfacing.

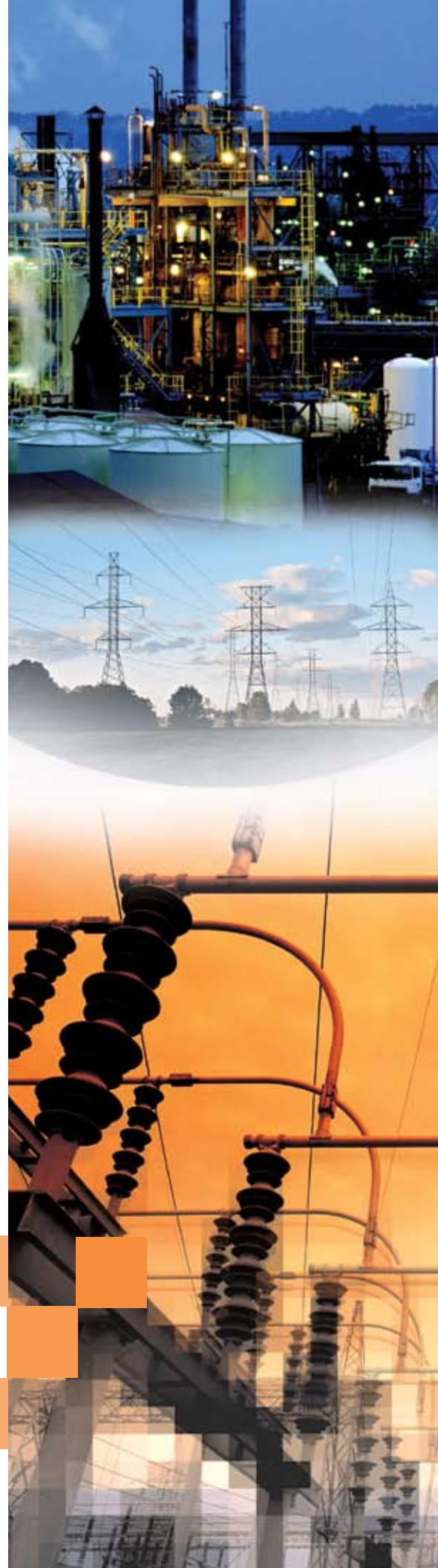



Intelligent metering and control devices

Used at key distribution points and sensitive loads, the PowerLogic ION7550 and ON7650 meters offer unmatched functionality including advanced power quality analysis coupled with revenue accuracy, multiple communications options, web compatibility, and control capabilities.

Integrate these meters with our PowerLogic® ION Enterprise® software or share operations data with existing SCADA systems through multiple communication channels and protocols.

Typical applications

For infrastructure, industrials and buildings

- Energy savings
 - Measure efficiency, reveal opportunities and verify savings
 - Reduce peak demand surcharges
 - Reduce power factor penalties
 - Strengthen rate negotiation with energy suppliers
 - Enable participation in load curtailment programs (e.g., demand response)
 - Identify billing discrepancies
 - Leverage existing infrastructure capacity and avoid over-building
 - Support proactive maintenance to prolong asset life
- Energy availability and reliability
 - Validate that power quality complies with the energy contract
 - Verify the reliable operation of equipment
 - Improve response to power quality-related problems

For electric utilities

- Energy availability and reliability
 - Improve T&D network reliability
 - Enhance substation automation to reduce field service time
 - Maximise the use of existing infrastructure
- Revenue metering and power quality
 - Install new high-accuracy metering at all interchange points
 - Improve or verify metering accuracy at existing interchange points
 - Verify compliance with new power quality standards
 - Analyse and isolate the source of power quality problems

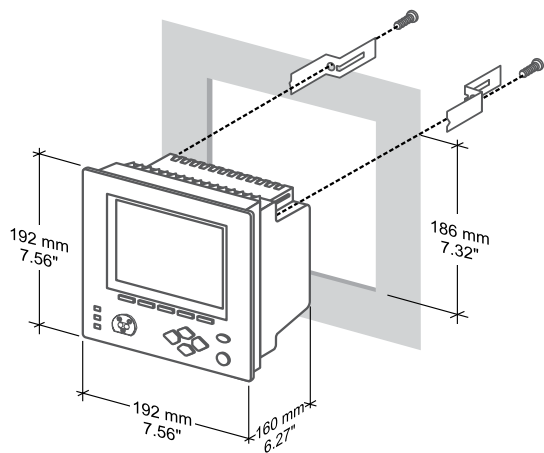

Installation

Designed to fit DIN standard 192 cutout (186 mm by 186 mm). Circuit and control power connections include 4-Wire Wye, 3-Wire Wye, 3-Wire Delta, Direct Delta and single phase systems. 4 voltage and 5 current inputs.

Input(s)	Specifications
Voltage inputs	
Nominal full scale:	347 direct V ac line-to-neutral, 600 V ac direct line-to-line, rms
Overload	1500 VAC rms continuous
Input impedance	5 M Ohms/phase (phase-Vref)
Fault capture	1200 Vpeak
Current inputs	
Nominal current	5 A, 10 A, and/or 20 A (1 A, 2 A, 5 A optional current range)
Max voltage	600 V rms (CAT III IEC 61010-1)
Withstand	2500 VAC, 60 Hz for 1 minute
Load/burden	0.05 VA per phase (at 5 A standard) 0.015 VA per phase (at 1 A optional)
Impedance	0.002 Ohms/phase (phase-Vref) 0.015 Ohms (optional current range)
Control power	
Operating range	Standard: AC: 85 to 240 V AC (+/-10%), 47 to 63 Hz; DC: 110 to 300 V DC (+/-10%); burden: typical 15 VA, max 35 VA Optional: low voltage DC power supply; rated inputs: DC 20 to 60 VDC (+/- 10%); burden: typical 12 VA, max 18 VA
Current probes with AC voltage output	
Rated inputs	1 V rms
Overload	5.5 V (CAT I IEC 61010-1)
Impedance	220 kOhms max.
Options	Current Probe Inputs for use with 0-1 VAC current probes. Probes sold separately. Accuracy depends on probe specs Current Probe Inputs with 3 calibrated Universal Technic 10A clamp-on CTs, meeting IEC 61036 accuracy

Front panel

Use for both display and configuration purposes. The large backlit LCD display screen and the numerous selection, navigation, and configuration softkeys allow quick, secure access to basic meter configuration screens. The front panel also provides access to many other meter functions such as meter resets and has multiple programmable screens for numeric and time-stamped values, frequency spectrum (harmonics), trend logs, and name plate data.



The large display automatically scrolls through displays screens that present at-a-glance volts, amps, power, energy and demand values. Screens are easily customised to suit user requirements. Set parameter measurements via front panel to comply with regional preferences. Modbus Master feature allows display of real-time parameters of any downstream modbus devices.

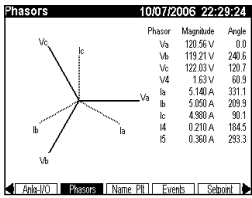

Phasors display

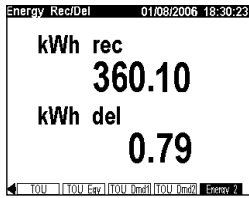

Energy received/delivered display

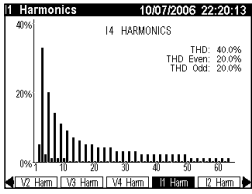

Harmonic current display

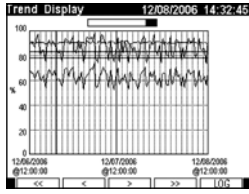

Trend display

Power and energy measurements

High-accuracy 4-quadrant energy metering in accordance with IEC 62053-22 class 0,2S for both 3- and 2-element systems. Real, bidirectional, reactive, and apparent values. Fully programmable integrating period (1, 5, 10, 15, 30, 60 minutes or other).

Supports block, rolling block, and predicted demand calculations such as: kW, kVAR and kVA demand, min/max; Volts and Amps demand, min/max; Cumulative demand; Demand on any instantaneous measurement.

Parameter	Accuracy ± (%reading)
Voltage (line-line, line-neutral): per phase, min/max, unbalance	0.1%
Frequency: present, min/max	±0.005 Hz
Current (I1, I2, I3)	0.1%
Current (I4, I5)	0.4%
Power: real (kW), reactive (kVAR), apparent (kVA), per-phase, total	IEC 62053-22 class 0,2S ²
Energy: real (kWh), reactive (kVARh), apparent (kVAh), in/out	IEC 62053-22 class 0,2S ²
kWA, kVA demand calculations	IEC 62053-22 class 0,2S ²
Power Factor (at Unity PF)	0.2%

¹ Refer to User's Manual for valid measurement ranges

² Refer to Compliance section. Not applicable for NICT meters, contact factory for measurement specifications

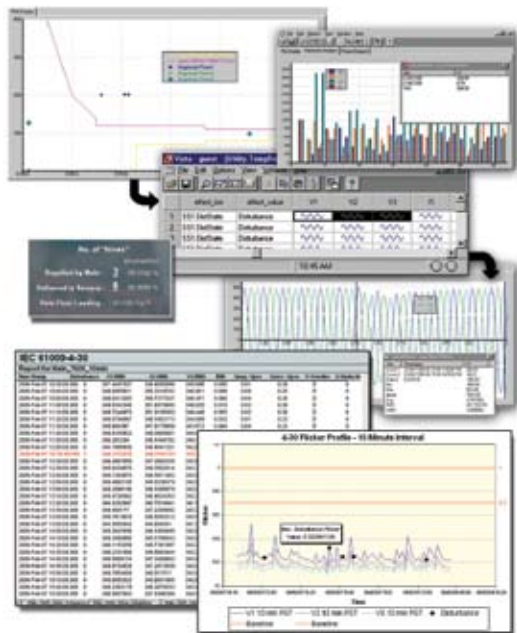

Example screen from PowerLogic ION Enterprise software showing continuous, wide-area monitoring, data capture and reporting for power quality and reliability conditions.

Power quality

Power quality compliance monitoring for international quality-of-supply standards plus specific data for localized and custom compliance agreements and network connection requirements.

- Harmonics (all models): individual harmonics up to the 63rd, K factor and Total Harmonics Distortion (THD).
- Sag/Swell (all models): voltage waveforms for sags and swells (i.e. ITI (CBEMA) Type 2 and Type 3 disturbances); report on each disturbance's magnitude and duration. Detect sub-disturbances during a sag/swell event.
- Disturbance direction detection (all models): analyze disturbance information to determine the direction of the disturbance relative to the meter. Results are provided in the event log, along with timestamp and the level of certainty of disturbance direction.
- EN50160 (ION7650 with EN50160 ordering option only): monitor compliance with EN50160 parameters.
- IEC 61000-4-30 (ION7650 only): monitor compliance of relevant 4-30 parameters such as power frequency, magnitude of supply voltage, flicker, supply voltage sags and swells, transients and voltage interruptions.
- Transient (ION7650 only): voltage waveforms of transient activity (i.e., ITI CBEMA Type 1 disturbances).

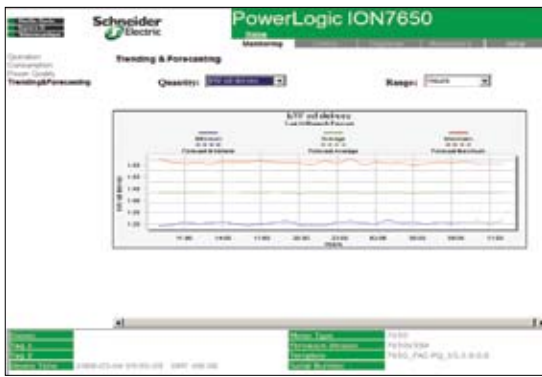

Trending and forecasting, as viewed from PowerLogic ION7650 web page.

Example Logging configurations

	ION7550		ION7650	
	500 events	500 events	500 events	500 Events
Data ^A	1.5 years	3.1 years	1.3 years	2.9 years
Waveforms	180 ^B	180 ^B	360 ^C	360 ^C

A: 16 parameters recorded every 15 minutes

B: 30 waveforms on 6 channels at the maximum sampling rate

C: 30 waveforms on 12 channels with any selectable format (for example, 6 channels are 512 samples per cycle for 4 cycles, and 6 channels are 32 samples per cycle for 54 cycles)

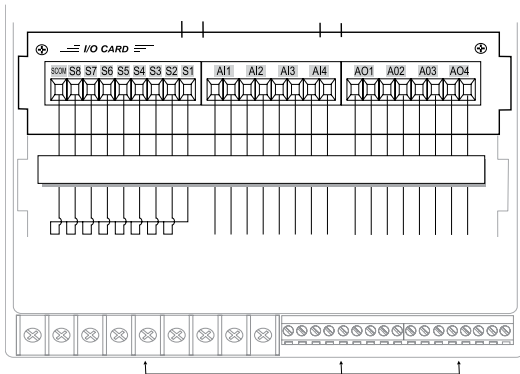

PowerLogic ION7650 I/O card.

Data and event logging

Ships with a comprehensive data-logging configuration. Data is prioritized and stored onboard in nonvolatile memory to eliminate data gaps in the event of outages or server downtime. Retrieved data is stored in an ODBC-compliant database when using ION Enterprise. Trending and forecasting capabilities track specified quantities over time and forecast the value of future quantities. View trending and forecasting data through the meter's web pages. Logging capacity is available in 5 MB or 10 MB configurations. Default depth and interval of logging is set at the factory, and depends upon onboard memory size.

- Revenue log: configured for use with UTS MV-90 billing software. Logs kWh del int, kWh rec int, kVARh del int, kVARh rec int values.
- Historic logs: record standard power system quantities, such as phase current, phase voltage and power factor.
- Report Generator log: configured to provide power system data for ION Enterprise software.
- Event log
- Trend display logs

Multiple tariffs and time-of-use (TOU) calculations

20-year calendar with automatic leap-year and seasonal time adjustments and clock synchronization over communications channel or GPS. TOU is configured four seasons, five daily profiles per season, four tariff periods per daily profile. Automatic mid-season rate change. Active, reactive, and apparent energy and demand; automatic recording of maximum (peak) demand during each tariff period.

Inputs and outputs

All models provide digital inputs as well as Form C (mechanical relays) and Form A (solid state relays) digital outputs. Optional digital and analog I/O is also available.

Digital output relays respond to internal alarms, external digital input status changes, or commands over communications. Use digital inputs to trigger alarms or logging, synchronize to a demand pulse or control conditional energy accumulation.

Type	Input / output	Specifications
Electromechanical relays	3 Form C relays: R1 - R3 Form C contacts: NO, K, NC	250 V AC / 30 V dc, max. voltage: 380 V AC / 125 V dc. Turn-on time: 15 ms max; Turn-off time: 5 ms max. Update rate: 1/2-cycle or 1 second
Solid state relays	4 Form A digital outputs: D1-D4 ¹	Maximum voltage: 30 V dc; maximum current: 80 mA; isolation: optical; update rate: 1/2-cycle or 1 second
Analog (option)	4 inputs: AI 1 to AI 4	Signal type: dc current; range: 0 to 20 mA (scalable 4 to 20), or 0 to 1 mA; accuracy: +/-0.3% of full scale ; update rate: 1 second
	4 outputs: AO1 to AO4	Signal type: dc current; range: 0-20 mA (scalable 4-20) or -1-1 mA (scalable 0-1); update rate: 1/2-cycle or 1 second
Digital	8 inputs: S1 - S8	SCOM self-excited, dry contact sensing, no external voltage required. Min pulse width: 1 ms; max pulse rate: 20 pulses/sec. Timing resolution: 1 ms; update rate: 1/2 cycle (after timing resolution); isolation: 300 Vpeak; max rated voltage 120 VDC (external excitation)
	8 inputs (option): DI1 - DI8	Self excited (internal 30 VDC supply); dry contact sensing, or with external excitation 1.3 to 0.1 mm ² (16 to 28 AWG); min pulse width: 20 ms; max pulse rate: 25 pulses per second; updated 1/2 cycle (after timing resolution)

EtherGate and ModemGate

The meters can provide gateway functionality depending on communication options.

EtherGate: provides access via ModbusTCP through the meter's Ethernet port to devices communicating via Modbus connected to the meter's serial ports.

ModemGate: provides access from the telephone network to devices connected to the meter's serial ports.

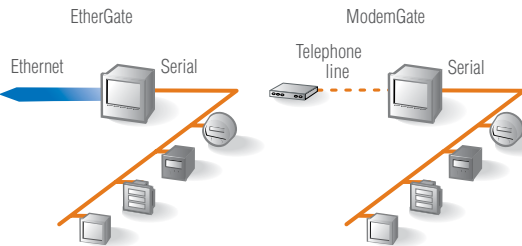

Internet connectivity

Exchange information using XML to integrate with custom reporting, spreadsheet, database, and other applications.

WebMeter: an on-board web server, provides access to real-time values and PQ data through any web-enabled device and even supports basic meter configuration tasks.

MeterM@i! automatically emails user-configured, high-priority alarm notifications or scheduled system-status update messages to anyone, anywhere within the facility or around the world.

Communications

Multiple communication ports that operate simultaneously allow the meters to be used as part of a power and energy management system and to interface with other automation systems. Upload waveforms, alarms, billing data, and more to software for viewing and analysis.

Port	Specifications
Serial RS-232/RS-485 port (COM 1)	Protocols include ION, Modbus RTU, Modbus Master, DNP 3.0, GPS, EtherGate, ModemGate. Data rates: 300 – 115,200 bps (RS-485 limited to 57,600 bps). Connectors: male DB9 (RS-232 DTE) or captured wire (RS-485). Duplex: Full (RS-232), Half (RS-485).
Serial RS-485 port (COM 2)	Protocols include ION, Modbus RTU, Modbus Master, DNP 3.0, GPS, EtherGate, ModemGate. Data rates: 300 – 57,600 bps 2400 to 38400. Duplex: Half
Internal modem (COM 3)	Data rates: 300 bps - 33.6 kbps (V.3.4, V.32 bis, V.32, V.22 bis, V.22 A/B, V.23, V.21, Bell 212A, Bell 103). Supports automatic data rate detection. RJ11 interface. Approvals: FCC P68 (USA), Industry Canada CS-03. Also approved for use in: Austria, Belgium, Denmark, Finland, France, Germany, Greece, Iceland, Ireland, Italy, Luxembourg, Netherlands, Norway, Portugal, Spain, Sweden, Switzerland, UK.
ANSI Type 2 optical port (COM 4)	Protocols include ION, DNP 3.0, Modbus RTU Data rates: 1200 - 19,200 bps. Half duplex.
Ethernet port	Protocols: TCP/IP, Telnet, ION, Modbus TCP, SNMP Interface: IEEE 802.3-1993, ISO/IEC 8802-3:1993 (Ethernet). Data rates: 10 Mbps, half duplex. 10BASE-T, 100BASE-TX: Connectors: RJ45, cabling: unshielded twisted-pair cable, 0.5 mm (24 AWG), max. length 100 meters (109 yards). Isolation: Transformer isolated to 1500 volts rms. 100BASE-FX (fibre) Connectors: ST; Cabling: Fibre optic cable, 62.5/125 µm nominal, wavelength 820 nm, max. length 2000 meters

Software integration

Integrate within PowerLogic facility-level or enterprise-wide power and energy management systems. Real-time data and data logs stored onboard can be automatically retrieved on a scheduled basis for analysis at the system level. Compatible with PowerLogic ION Enterprise and PowerLogic ION Setup. Modbus compatibility and register-based logged data supports integration and data access by building automation, SCADA and other third-party systems.

Special features

Flash-based firmware allows upgrades via communications without removing the meter from the site. Simply download the latest firmware from www.powerlogic.com. Real time data, data logs and waveforms stored on board.

General specifications

Description	Specifications
Accuracy	IEC 62053-22 0,2S, 1 A and 5 A tested by KEMA; Complies with ANSI C12.20, Class 10 & Class 20
Safety/construction	IEC 1010-1 (EN61010-1); CSA C22.2 No 1010-1; UL 61010B-1 Electromagnetic Immunity; IEEE C.37-90.1-1989; EN50082-2
Electromagnetic compatibility	IEC 61000-4-2 (EN61000-4-2/IEC 8012); IEC 61000-4-3 (EN61000-4-3/IEC 801-3) Radiated EM Field Immunity IEC 61000-4-4 (EN61000-4-4/IEC 801-4) Electric Fast Transient; IEC 61000-4-5 (EN61000-4-5/IEC 801-5) Surge Immunity IEC 61000-4-6 (EN61000-4-6/IEC 801-6) Conducted Immunity; IEC 61000-3-2 (EN61000-3-2); IEC 61000-3-3 (EN61000-3-3) FCC Part 15 Subpart B, Class A Digital Device; EN55011 (CISPR 11); EN55022 (CISPR 22); EN61000-6-4 (EN50081-2)
Environmental conditions	Operating temperature: -20° C to +70° C (no formation of ice) (-4° F to 158° F) Low Voltage DC Power Supply: -20° C to 50° C (-4° F 122° F) Storage: -40° C to +85° C (-40° F to 185° F) Humidity: 5% to 95% non-condensing

Features	ION7550	ION7650
Metering		
Power, energy & demand	■	■
Power quality		
Sag/swell, harmonics monitoring	■	■
Harmonics: individual, even, odd, up to	63rd	63rd
Harmonics: magnitude, phase and inter-harmonics		50th
Symmetrical components: zero, positive, negative	■	■
Recording compliant with IEC 61000-4-30 Class A		■
IEC61000-4-15 flicker		■
EN50160 compliance checking		■
Transient detection, microseconds (20µs for 50Hz, 17µs for 60Hz)		20/17
Sampling rate, maximum samples per cycle	256	1024
Disturbance direction detection	■	■
Logging and recording		
Memory standard/optional	5 MB/10 MB	5 MB/10 MB
Min/max, historical, waveform logging	■	■
Timestamp resolution in seconds	0.001	0.001
Historical trend information via front panel display	■	■
GPS time synchronization	■	■
Communications and I/O		
RS-232/485; RS-485; Ethernet; Optical	■	■
Internal modem	1	1
3-port DNP 3.0 via serial, modem, Ethernet, I/R ports	■	■
Modbus RTU slave/master; Modbus TCP	■	■
EtherGate, ModemGate, MeterM@il, WebMeter	■	■
Analog inputs/outputs (optional)	4/4	4/4
Digital status inputs/outputs	16/4	16/4
Relay outputs (standard)	3	3
Setpoints, alarming, and control		
Setpoints, number/minimum response time	65/1 ² -cycle	65/1 ² -cycle
Math, logic, trig, log, linearization formulas	■	■
Call-out on single & multi-condition alarms	■	■
Alarm setpoint learning	■	■

Software integration

PowerLogic® ION Enterprise® Software

ION® Setup Software

Modbus® Master

Internet Connectivity

XML Compatibility

Flash-based firmware

Perform upgrades via communications without removing the meter from the site.

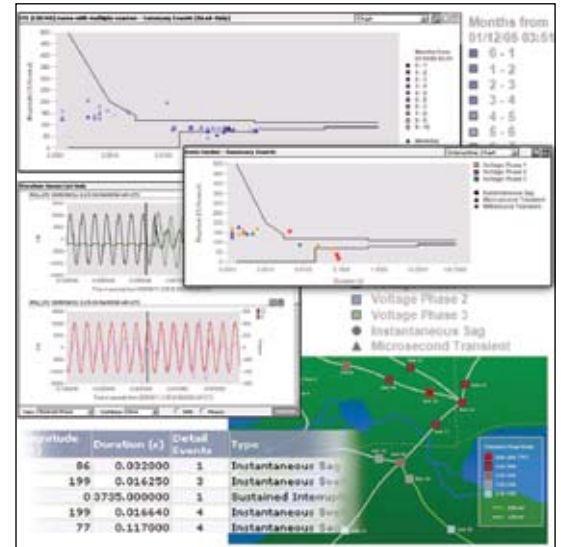

Certificate No. 002188

Schneider Electric - North American Operating Division
 295 Tech Park Drive
 LaVergne, TN 37086
 Ph: 615-287-3500
<http://www.PowerLogic.com>

As standards, specifications and designs develop from time, always ask for confirmation of the information given in this publication. Square D, PowerLogic, ION, ION Enterprise, MeterM@il and Modbus are either trademarks or registered trademarks of Schneider Electric or its affiliates. Other marks used herein may be the property of their respective owners.

