

# PowerLogic® ION7300 Series

Power & Energy Meter

Installation Guide

July 2006





---

## Danger



This symbol indicates the presence of dangerous voltage within and outside the product enclosure that may constitute a risk of electric shock, serious injury or death to persons if proper precautions are not followed.

## Caution



This symbol alerts the user to the presence of hazards that may cause minor or moderate injury to persons, damage to property or damage to the device itself, if proper precautions are not followed.

## Note



This symbol directs the user's attention to important installation, operating and maintenance instructions.

# Installation Considerations

Installation and maintenance of the ION7300 Series meter should only be performed by qualified, competent personnel that have appropriate training and experience with high voltage and current devices. The meter must be installed in accordance with all local and national electrical codes.



## DANGER

---

Failure to observe the following instructions may result in severe injury or death.

---

- ◆ During normal operation of the ION7300 Series meter, hazardous voltages are present on its terminal strips, and throughout the connected potential transformer (PT), current transformer (CT), digital (status) input, control power and external I/O circuits. PT and CT secondary circuits are capable of generating lethal voltages and currents with their primary circuit energized. Follow standard safety precautions while performing any installation or service work (i.e. removing PT fuses, shorting CT secondaries, etc).
- ◆ The terminal strips on the meter base should not be user-accessible after installation.
- ◆ Do not use digital output devices for primary protection functions. These include applications where the devices perform energy limiting functions or provide protection of people from injury. Do not use the ION7300 Series in situations where failure of the devices can cause injury or death, or cause sufficient energy to be released that can start a fire. The meter can be used for secondary protection functions.
- ◆ Do not HIPOT/Dielectric test the digital (status) inputs, digital outputs, or communications terminals. Refer to the label on the ION7300 Series meter for the maximum voltage level the device can withstand.



## CAUTION

---

Observe the following instructions, or permanent damage to the meter may occur.

---

- ◆ The ION7300 Series meter offers a range of hardware options that affect input ratings. The ION7300 Series meter's serial number label lists all equipped options. Applying current levels incompatible with the current inputs will permanently damage the meter. This document provides installation instructions applicable to each hardware option.
- ◆ The ION7300 Series meter's chassis ground must be properly connected to the switchgear earth ground for the noise and surge protection circuitry to function correctly. Failure to do so will void the warranty.
- ◆ Terminal screw torque: Barrier-type (current, voltage, and relay terminal screws: 1.35 Nm (1.00 ft-lbf) max. Captured-wire type (digital inputs/outputs, communications, power supply: 0.90 Nm (0.66 ft.lbf) max.

## FCC Notice

This equipment has been tested and found to comply with the limits for a Class A digital device, pursuant to Part 15 of the FCC Rules. These limits are designed to provide reasonable protection against harmful interference when the equipment is operated in a commercial environment. This equipment generates, uses, and can radiate radio frequency energy and, if not installed and used in accordance with the instruction manual, may cause harmful interference to radio communications. Operation of this equipment in a residential area is likely to cause harmful interference in which case the user will be required to correct the interference at his own expense.

---

The Ringer Equivalence Number (REN) for the ION7300 Series optional internal modem is 0.6. Connection to the ION7300 Series internal modem should be made via an FCC Part 68 compliant telephone cord (not supplied). The ION7300 Series cannot be used on a public coin phone service or party line services.

## Network Compatibility Notice for the Internal Modem

The internal modem in meters equipped with this option is compatible with the telephone systems of most countries in the world, with the exception of Australia and New Zealand. Use in some countries may require modification of the internal modem's initialization strings. If problems using the modem on your phone system occur, please contact Schneider Electric Technical Support

## Standards Compliance



CSA: Certified to CAN/ CSA C22.2 No. 1010-1    Certified to UL 3111

Made by Power Measurement Ltd.

PowerLogic, ION, ION Enterprise, MeterM@il and Modbus are either trademarks or registered trademarks of Schneider Electric.

Covered by one or more of the following patents:

U.S. Patent No's 7010438, 7006934, 6990395, 6988182, 6988025, 6983211, 6961641, 6957158, 6944555, 6871150, 6853978, 6825776, 6813571, 6798191, 6798190, 6792364, 6792337, 6751562, 6745138, 6737855, 6694270, 6687627, 6671654, 6671635, 6615147, 6611922, 6611773, 6563697, 6493644, 6397155, 6236949, 6186842, 6185508, 6000034, 5995911, 5828576, 5736847, 5650936, D505087, D459259, D458863, D443541, D439535, D435471, D432934, D429655, D427533.

# PowerLogic ION7300 Series Models

## Integrated Display Model

Comes with front infrared (IR) port.

## TRAN (transducer) Model

The TRAN model has no display. You can connect a Remote Modular Display unit (RMD) to the TRAN to display measurement values.

## Switchboard Model

The switchboard meter consists of the meter chassis, the cover assembly, and a ribbon cable to connect the display to the meter base.

## RMICAN Model

An integrated display meter that is RMICAN-certified for revenue metering in Canada. RMICAN meters have different security options available, including a factory-sealed version.

## Available Options

		Option				
		Form Factor	Power Supply	COM	I/O	Security
Model	ION7300	<ul style="list-style-type: none"> <li>◆ Integ. Display</li> <li>◆ TRAN</li> <li>◆ Switchboard</li> </ul>	<ul style="list-style-type: none"> <li>◆ Standard</li> <li>◆ P24</li> </ul>	<ul style="list-style-type: none"> <li>◆ Standard (one RS-485 port)</li> <li>◆ Ethernet</li> <li>◆ Profibus</li> </ul>	<ul style="list-style-type: none"> <li>◆ Standard (four digital outputs)</li> <li>◆ four 0-1 mA analog inputs</li> <li>◆ four 0-20 mA analog inputs</li> <li>◆ four 0-1 mA analog outputs</li> <li>◆ four 0-20 mA analog outputs</li> </ul>	<ul style="list-style-type: none"> <li>◆ Standard<sup>1</sup></li> <li>◆ RMANSI<sup>2</sup></li> <li>◆ OFGEM<sup>3</sup></li> </ul>
	ION7300 RMICAN	<ul style="list-style-type: none"> <li>◆ Integ. Display only</li> </ul>	<ul style="list-style-type: none"> <li>◆ Standard</li> <li>◆ P24</li> </ul>	<ul style="list-style-type: none"> <li>◆ Standard only (one RS-485 port)</li> </ul>	<ul style="list-style-type: none"> <li>◆ Same as ION7300</li> </ul>	<ul style="list-style-type: none"> <li>◆ RMICAN</li> <li>◆ RMICAN sealed</li> </ul>
	ION7330	<ul style="list-style-type: none"> <li>◆ Integ. Display</li> <li>◆ TRAN</li> <li>◆ Switchboard</li> </ul>	<ul style="list-style-type: none"> <li>◆ Standard</li> <li>◆ P24</li> </ul>	<ul style="list-style-type: none"> <li>◆ Standard (two RS-485 ports)</li> <li>◆ Ethernet</li> <li>◆ Modem</li> </ul>	<ul style="list-style-type: none"> <li>◆ Standard (four digital inputs and four digital outputs)</li> <li>◆ Same analog options as ION7300</li> </ul>	<ul style="list-style-type: none"> <li>◆ Standard</li> <li>◆ RMANSI</li> <li>◆ OFGEM</li> </ul>
	ION7330 RMICAN	<ul style="list-style-type: none"> <li>◆ Integ. Display only</li> </ul>	<ul style="list-style-type: none"> <li>◆ Standard</li> <li>◆ P24</li> </ul>	<ul style="list-style-type: none"> <li>◆ Same as ION7330</li> </ul>	<ul style="list-style-type: none"> <li>◆ Same as ION7330</li> </ul>	<ul style="list-style-type: none"> <li>◆ RMICAN<sup>4</sup></li> <li>◆ RMICAN sealed<sup>5</sup></li> </ul>
	ION7350	<ul style="list-style-type: none"> <li>◆ Integ. Display</li> <li>◆ TRAN</li> <li>◆ Switchboard</li> </ul>	<ul style="list-style-type: none"> <li>◆ Standard</li> <li>◆ P24</li> </ul>	<ul style="list-style-type: none"> <li>◆ Same as ION7330</li> </ul>	<ul style="list-style-type: none"> <li>◆ Same as ION7330</li> </ul>	<ul style="list-style-type: none"> <li>◆ Standard</li> <li>◆ RMANSI</li> <li>◆ OFGEM</li> </ul>

## Notes

- <sup>1</sup> Standard = front-panel password protected, no locking or sealing.
- <sup>2</sup> RMANSI = ANSI C12.16 approved; meets ANSI C12.20 class 0.5 accuracy at 25°C (77°F). For 10 A current inputs only.
- <sup>3</sup> Meets IEC 60687 Class 0.5 (for 5 Amps nominal). The OFGEM option is only available in the United Kingdom.
- <sup>4</sup> Meets Industry Canada Locking Requirements (10 A current inputs only).
- <sup>5</sup> Meets Industry Canada Locking Requirements and Factory Sealed (only for delivery to Canada).

# Before You Begin

Before installing the meter, familiarize yourself with the steps in this guide and read the safety precautions presented on the "Installation Considerations" page.

## DANGER

Do not power up the meter until the current and voltage wiring is completed.

### Recommended Tools

- ◆ #1 Phillips screwdriver
- ◆ Precision flat-head screwdriver
- ◆ Wire cutters / stripper

# Meter Overview

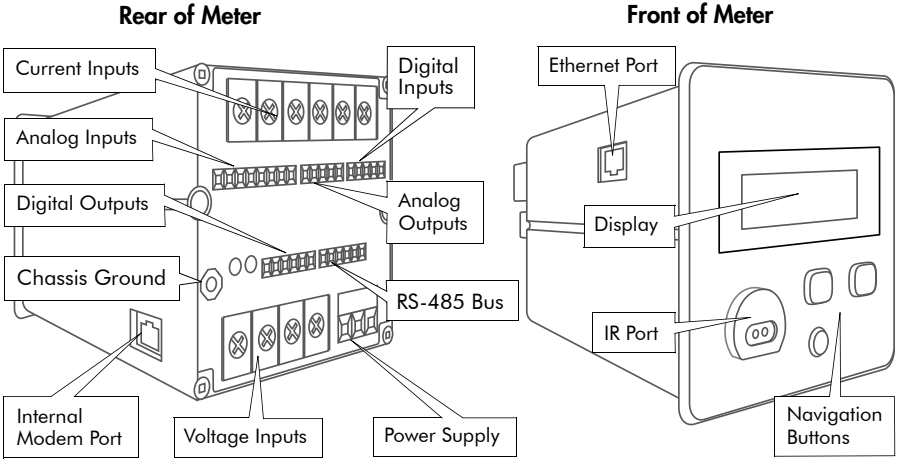

# Using the Buttons

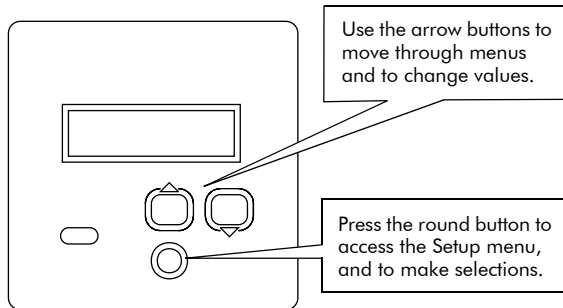

# Unit Dimensions

## Basic Model Dimensions

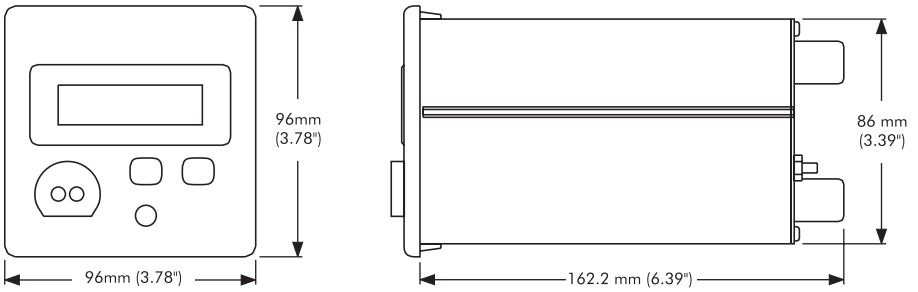

## TRAN Model Dimensions

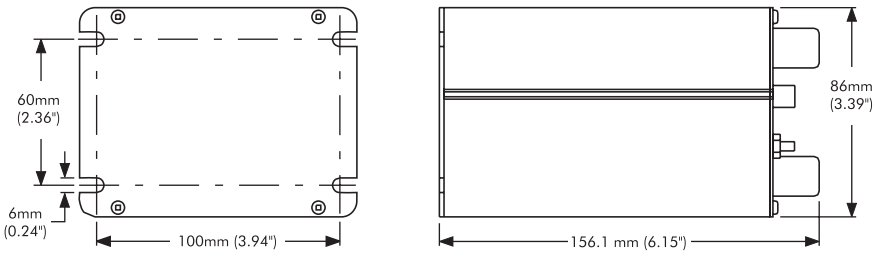

## RMD Dimensions

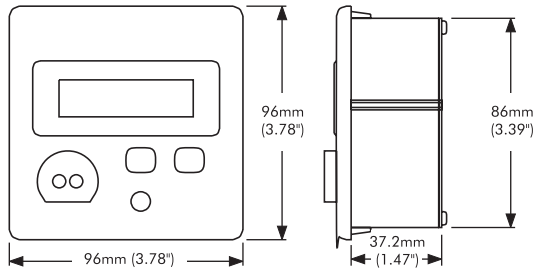

## Ethernet Port Location (if equipped)

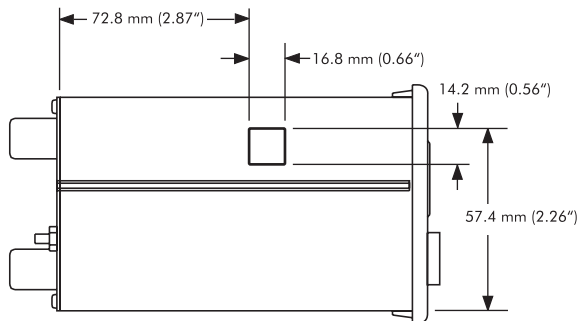

---

## Internal Modem Port Location (if equipped)

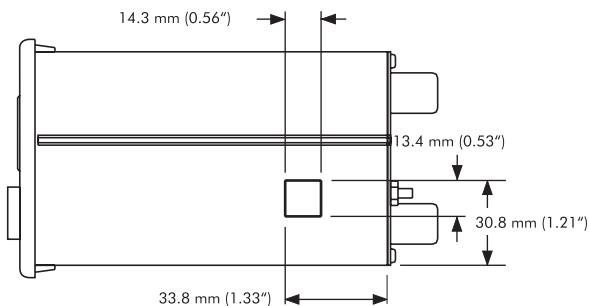

## Additional Information

### Switchboard Meters

See the *ION7300 Series Switchboard Meter* document for more information.

### REB (Grayhill Rack) Option

The REB (Relay Expansion Board) option allows for custom digital output applications using specific Grayhill modules. See the *ION7300 Series REB Option* document for more information.

### GSKT Option

The GSKT (gasket) option helps to prevent moisture from penetrating air gaps between your ION7300 series meter and its mounting hole. See the *GSKT Option Installation Instructions* for more information.

### RAP Option

The RAP option (Round Adapter Plate) lets you install a ION7300 series Display or RMD meter into an existing round (ANSI) cutout. See the *RAP Option Installation Instructions* for more information.

### Terminal Cover Option

This option covers the terminal strips on the meter's base so they are not accessible after installation. See the *Terminal Cover Option Retrofit Instructions* for more information.

# Step 1: Mount the Meter

Once installed, no cleaning of the device is necessary.

Mounting Location	Indoor
Operating Temperature	Base Unit: -20°C (-4°F) to 60°C (140°F)
Storage Temperature	-30°C (-22°F) to +85°C (185°F)
Relative Humidity	5% to 95% RH non-condensing
Altitude	Less than 2000 m (6100 ft.) above sea level

## Mounting the Basic Model

1. Fit the unit into the cutout [DIN standard 92 X 92 mm or 3.6" X 3.6"] then slide the supplied slide bars into the grooves on either side of the unit.
2. Insert the thumbscrews in the back of the meter and tighten them until the slide bars securely anchor the unit to the cabinet door. Do not overtighten.

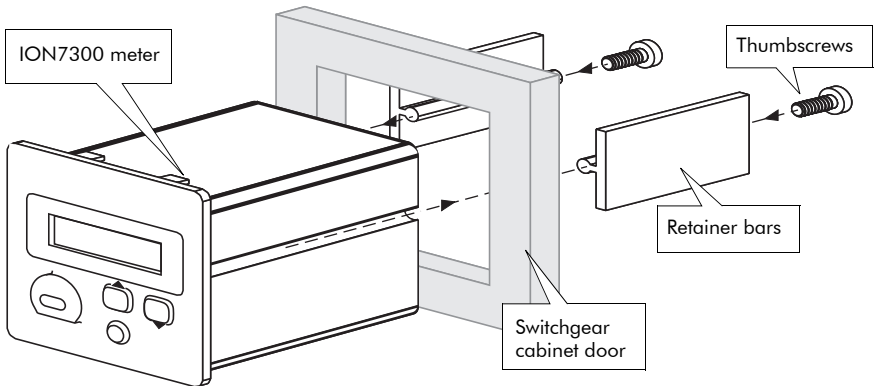

## Mounting the TRAN Model

The TRAN base unit can be mounted three different ways:

- ◆ Flush against any flat surface. The unit provides four slots on its mounting flange for this purpose. It can be mounted in whichever orientation is most convenient.
- ◆ Attached to any standard DIN rail (if the TRAN unit was purchased with the optional DIN rail mount).
- ◆ Installed in a cutout. To install a TRAN this way, follow directions for mounting a basic model (see above). Once installed, connect the optional RMD to the TRAN using the cable provided.

## Mounting the RMD (if equipped)

1. Insert the RMD into the panel cutout.
2. Hand-tighten the securing screws on each cable connector.
3. Connect the chassis ground lug on the RMD to the switchgear earth ground for the noise and surge protection circuitry to function correctly.

### Remote Modular Display Connections

Connector Type	DB25
Wire	1.8 m (6 ft.) cable

### Connecting the RMD to the TRAN Unit

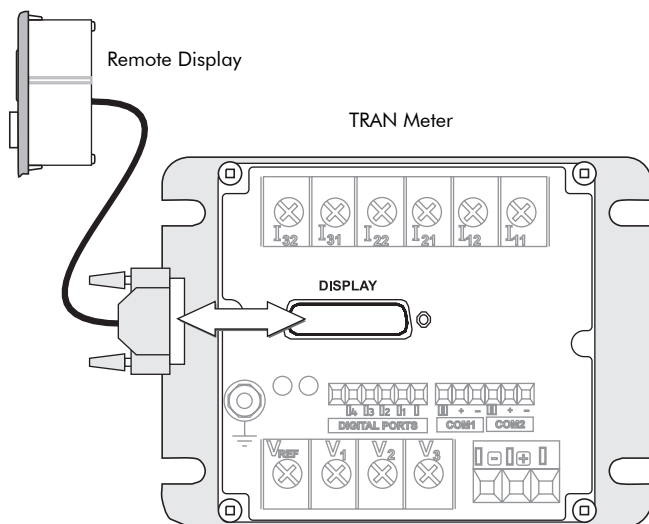

### NOTE

Only use cable supplied by Schneider Electric to connect the RMD.

## Step 2: Wire the Chassis Ground

Wire the meter's ground terminal (⊕) to the switchgear earth ground using a 14 AWG (2.1 mm<sup>2</sup>) or larger wire.

Connect the power supply G (ground) terminal to the same point as the meter (⊕) terminal.

### CAUTION

Do not use metal door hinges as a ground path.

# Step 3: Wire the Digital and Analog I/O

## Digital Output Connections

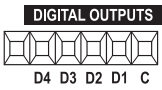

Output Type	Form A Solid State
Outputs	D1, D2, D3, D4
Wire	28 to 16 AWG (0.1 to 1.3 mm <sup>2</sup> )
Connector Type	Captured wire
Signal Type	Continuous or pulse
Max. Load Voltage	30 V
Max. Forward Current	80 mA
Isolation	Optical

### Typical Form A Application

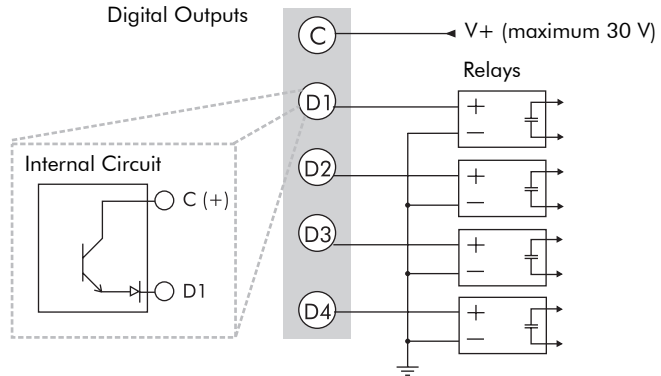

**NOTE**

Use only Schneider Electric approved external relays.

## Digital Input Connections (if equipped)

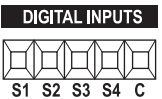

Input Type	Self-excited (internal 30 VDC supply)
Inputs	S1, S2, S3, S4
Application	Dry contact sensing, or with external excitation.
Wire	28 to 16 AWG (0.1 to 1.3 mm <sup>2</sup> )
Connector Type	Captured wire
Min. Pulse Width	25 milliseconds
Max. Transition Rate	40 transitions per second (20 Hz)

## Typical Digital Input Application

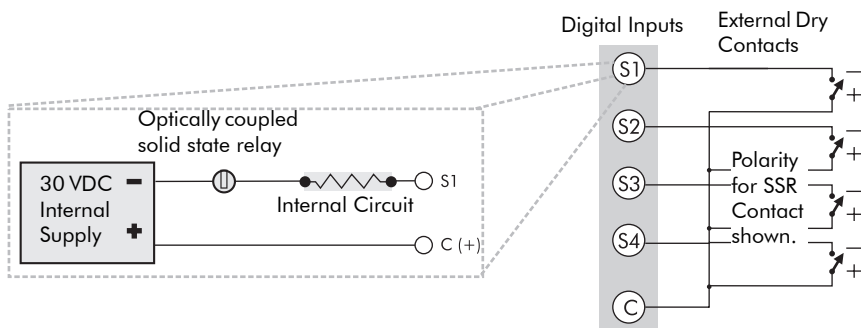

## Analog Input Connections (if equipped)

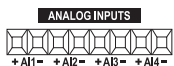

Specification	0-20 mA (scalable to 4-20 mA) Option	0-1 mA Option
Input Impedance	25 $\Omega$	475 $\Omega$
Maximum Source Impedance	500 $\Omega$	10 k $\Omega$
Accuracy	$\pm 0.3\%$ of full-scale	
Inputs	AI1, AI2, AI3, AI4	
Connectors	Phoenix captured-wire	
Update Rate	1 Hz	
Channel to Channel Isolation	None	
Max. Common Mode Voltage	30 V	
Standards Compliance	IEC 61000-4-4 fast transient test with capacitive clamp (4 kVp-p@2.5 kHz for 1 min)	

## Typical Analog Input Application

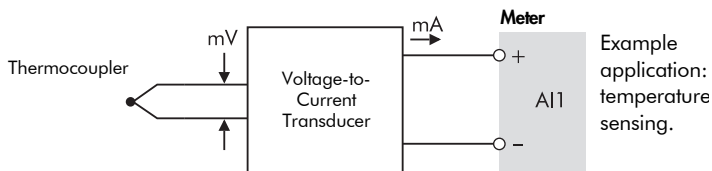

# Analog Output Connections (if equipped)

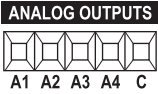

Specification	0-20 mA (scalable to 4-20 mA) Option	0-1 mA Option
Max. Load Drive Capability	500 Ω	10 kΩ
Accuracy	±0.3% of full-scale	
Outputs	A1, A2, A3, A4	
Connectors	Phoenix captured-wire	
Channel to Channel Isolation	None	
Max. Common Mode Voltage	30 V	
Standards Compliance	IEC 61000-4-4 fast transient test with capacitive clamp (4 kVp-p@2.5 kHz for 1 min.)	

## Typical Analog Output Application

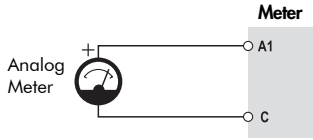

Example application: driving an analog meter with the DC current output.

# Step 4: Wire the Voltage and Current Inputs

## Voltage Input Specifications

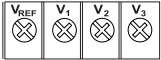

Terminal Type	Barrier or captured wire
Connector Type	Ring or split-ring, or bare wire
Wire	14 to 12 AWG (2.1 to 3.3 mm <sup>2</sup> )
Inputs	V1, V2, V3, Vref
Rated Inputs <sup>1</sup>	<ul style="list-style-type: none"> <li>◆ 50 - 347 L-N (87 - 600 L-L) VAC RMS (3-phase systems)</li> <li>◆ 50 to 300 L-N (100 to 600 L-L) VAC RMS (single-phase systems)</li> </ul>
Oversrange	+ 25%
Compliance	Installation category III (Distribution) Pollution degree 2
Overload	1500 VAC RMS continuous
Dielectric Withstand	3250 VAC RMS for one second (non-recurring)
Impedance	> 2 MΩ/phase (phase-vref)

<sup>1</sup> Accuracy may be affected if the voltage on V1 falls below 50.

## Current Input Specifications



Terminal Type	Barrier or captured wire
Connector Type	Ring or split-ring, or bare wire
Wire	14 to 12 AWG (2.1 to 3.3 mm <sup>2</sup> )
Inputs	I1, I2, I3
Rated Inputs	10 A RMS (+ 20% maximum, 300 V RMS to ground)
Compliance	Installation category III (Distribution) Pollution degree 2
Overload	20 A continuous
Dielectric Withstand	500 A for one second (non-recurring)
Burden	0.0625 VA @ 10 Amps

### Using Current Transformers

The meter is compatible with CTs that have 5 Amp nominal, 10 Amp full-scale secondaries.

Compliance	UL3111-1; and IEC 61010-1, Pollution Degree 2, Overvoltage Category III
Primary CT Rating	Equal to current rating of the power feed protection device. <sup>1</sup>
Secondary CT Burden Capacity	> 3 VA

<sup>1</sup> If the peak anticipated load is considerably less than the rated system capacity, you can improve accuracy and resolution by selecting a lower rated CT.

### NOTE

Refer to the *ION7300 Series User Guide* for Revenue Metering CT and PT selection.

## 4-Wire Wye, 3-Element, Direct Connection Diagram

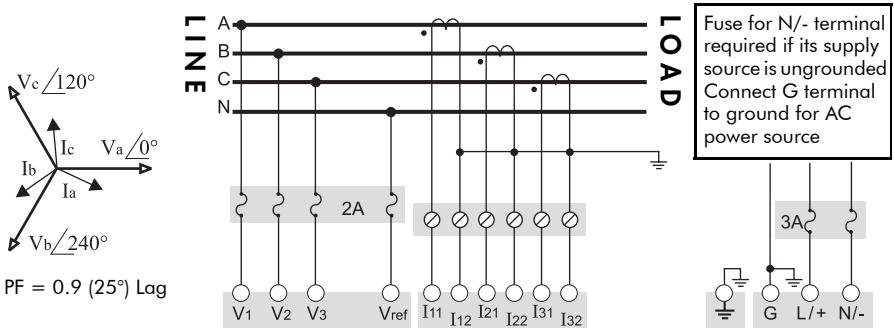

347 V L-N or 600 V L-L max.  
VOLTS MODE = 4W-WYE

## 4-Wire Wye, 3-Element, 3 PT Connection Diagram

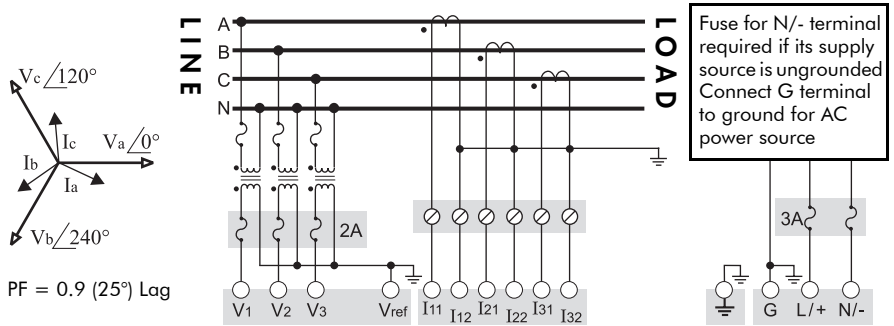

Use PTs for voltages over 347 V L-N or 600 V L-L  
VOLTS MODE = 4W-WYE

## 4-Wire Wye, 2½-Element, 2 PT Connection Diagram

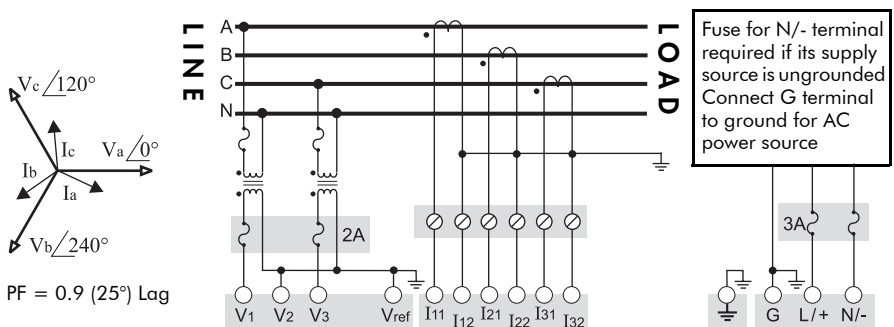

Phase B voltage (V2) is derived from phase A and C voltages.  
Use PTs for voltages over 347 V L-N or 600 V L-L  
VOLTS MODE = 3W-WYE

### 3-Wire Grounded Wye, 3-Element, Direct Connection Diagram

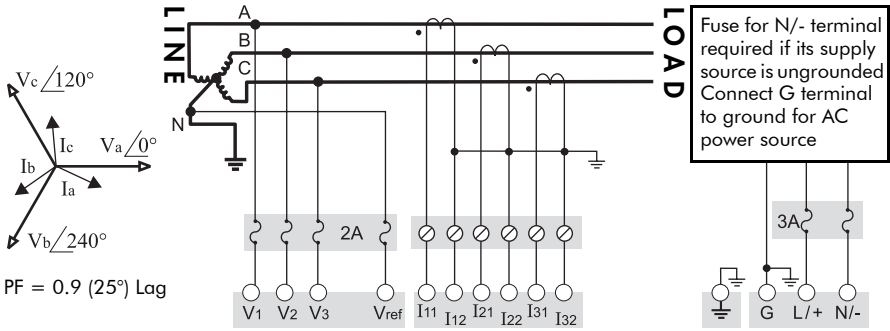

The configuration requires that the transformer secondary star-point is grounded. The phase-to-ground voltages must be within the meter's range.  
 VOLTS MODE = 4W-WYE

### 3-Wire Delta, 2 1/2-Element, 2 PT & 3 CT Connection Diagram

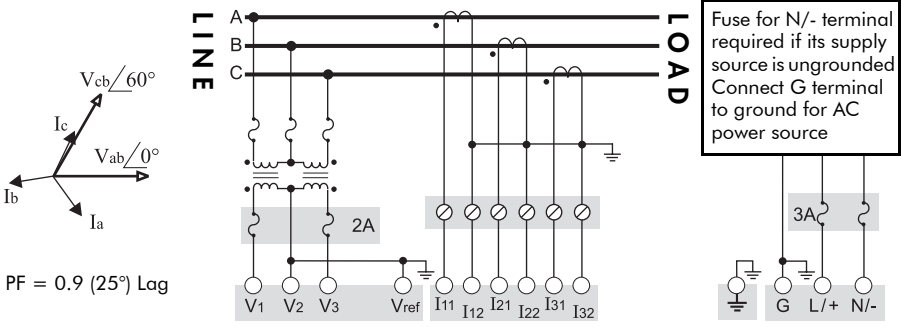

Use PTs for voltages over 600 V L-L  
 VOLTS MODE = DELTA

### 3-Wire Delta, 2-Element, 2 PT & 2 CT Connection Diagram

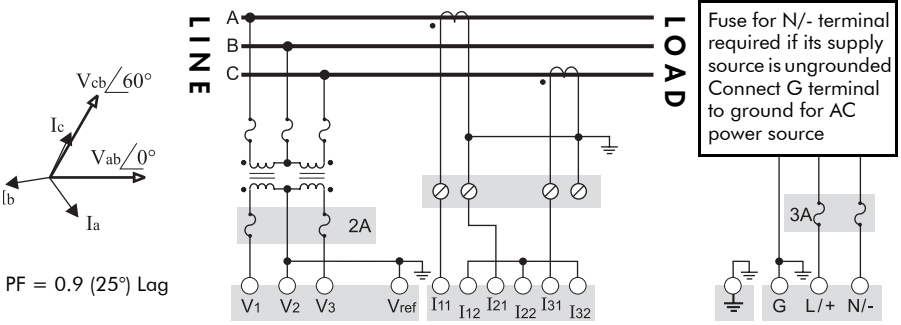

Use PTs for voltages over 600 V L-L  
 VOLTS MODE = DELTA

### 3-Wire Delta Direct Connection

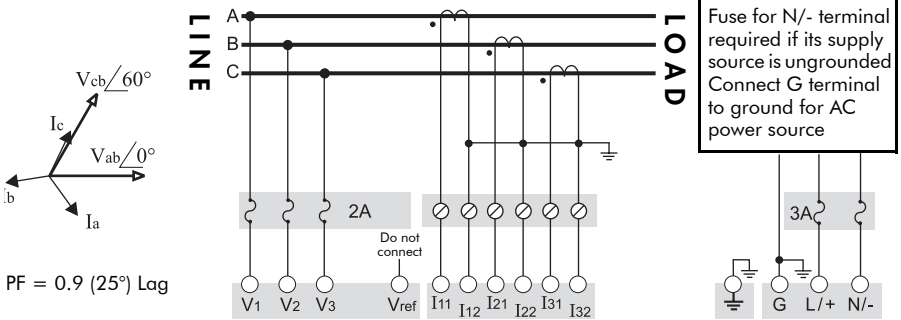

### Single Phase Connection Diagram

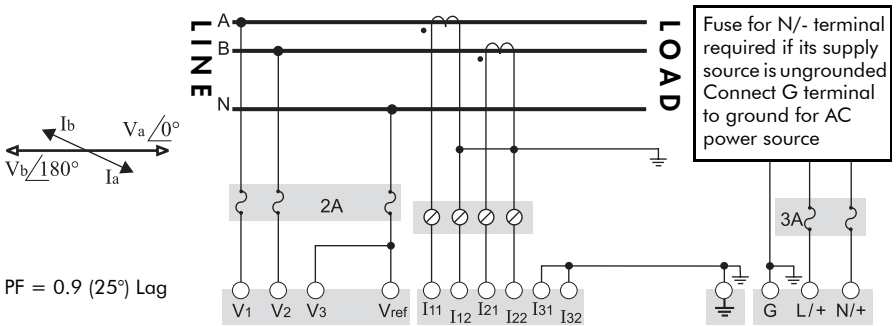

### Using Potential Transformers

System Mode	Voltage Range	Requires PTs
Wye	120 V L-N or 208 V L-L	no
	277 V L-N or 480 V L-L	no
	347 V L-N or 600 V L-L	no
	over 347 V L-N or 600 V L-L	yes
Single Phase	120 V L-N or 240 V L-L	no
	277 V L-N or 554 V L-L	no
	over 277 V L-N or 554 V L-L	yes
Delta	up to 600 V L-L	no
	over 600 V L-L	yes

# Step 5: Wire the Communications

## RS-485 Specifications (COM1 and COM2)

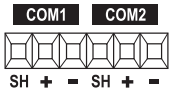

Connector Type	Captured wire
Wire	Shielded twisted pair RS-485 cable, 22 AWG (0.33 mm <sup>2</sup> ) or larger
Maximum Cable Length	1219 m (4000 ft)
Maximum Devices (per bus)	32
Input	Optically isolated
Compliance	ANSI/IEEE C37.90-1989 surge withstand and fast transient tests

### NOTE

COM2 port is unavailable on ION7300 meters.

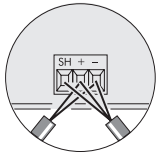

Connect SH at one end only.

### RS-485 Connection

Marking	Terminal Function
SH	RS-485 Shield (electrically connected to chassis ground)
+	RS-485 Data Plus
-	RS-485 Data Minus

### Infrared Connection (COM3)

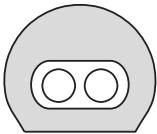

The infrared serial communications port can be used for energy pulsing or communication with Schneider Electric power monitoring software.

This port is compatible with an ANSI Type II magnetic optical communications coupler.

Connect the coupler to the port on the front of the meter.

### Ethernet Connection (if equipped)

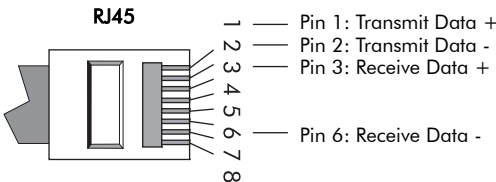

Wire Type	High quality Category 3 or 5 UTP (CAT 5 unshielded twisted pair recommended) cable
Connector Type	RJ45 modular
Type (10 Base-T)	IEEE 802.3 10Base-T for 10 Mbps base band CSMA/CD LANs
Data Rate	10 Mbps
Supported Protocols	ION, Modbus RTU <sup>1</sup> , Modbus/TCP <sup>1</sup>
Isolation	Transformer isolated to 1500 VAC RMS

<sup>1</sup> The unit ID for Modbus RTU and Modbus/TCP over Ethernet is 100.

### NOTE

On ION7330 and ION7350 meters with the Ethernet card, COM2 is hardwired for EtherGate only, and cannot be used for serial communication.

### Ethernet TCP/IP Service Ports

Protocol	Port
ION	7700
Modbus RTU	7701
Modbus/TCP	502
EtherGate (COM2)	7802

The meter supports a single connection at a time, to one of these three IP Service Ports: ION (Port 7700), Modbus/TCP (Port 502), or Modbus RTU (Port 7701). At the same time, connections to EtherGate (Port 7802), WebMeter, and MeterM@il can be made.

### Internal Modem Connection (if equipped)

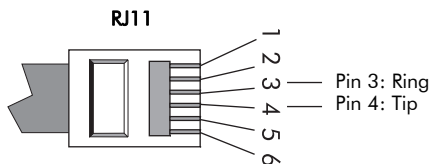

	RJ-11 Option	Captured Wire Option
Connector Type	RJ-11	Captured wire
Wire Type	FCC Part 68 compliant telephone cord (two male RJ-11 ends)	Bare wire to RJ-11 cable <sup>1</sup>
Data Rate	19.2 kbps	19.2 kbps
Supported Protocols	ION, Modbus RTU, Modbus/TCP	ION, Modbus RTU, Modbus/TCP

<sup>1</sup> Provided with your meter.

 **NOTE**

On meters with the modem option, the internal modem is hardwired to COM1, and that communications port is permanently set to ModemGate. If you want to connect another meter with an internal modem to the ION7300 series, you must connect it in a serial loop using COM2. COM1 cannot be used, as the two modems (internal modem in the ION7300 series and internal modem in the serial loop connected meter) conflict during communication.

## Profibus Connections (if equipped)

Connector Type	9-pin
Data Rate	12 Mbps

 **NOTE**

The Profibus option is only available on ION7300 meters.

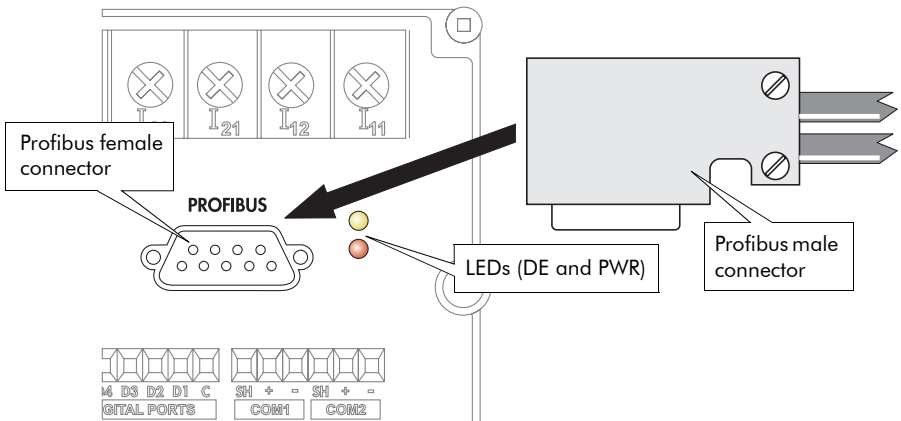

**Profibus Female Connector  
(located on meter)**

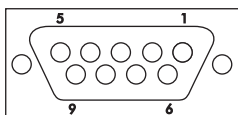

Pin Number	Profibus Function
1	N/A
2	N/A
3	B-line
4	RTS
5	Isolated GND
6	Isolated Vcc
7	N/A
8	A-line
9	N/A

 **NOTE**

The Profibus Master file (.GSD file) is included on a floppy disk with the meter. This file must be installed on your Profibus Masters before the meter can communicate with the Profibus network.

## Step 6: Wire the Power Supply

### Power Supply Specifications

Power Supply	Rated Inputs	Maximum	Connector Type	Wire
Standard AC / DC power supply	AC: 95 - 240 VAC ±10% (47 - 440 Hz) DC: 120 - 310 VDC ±10%	0.2 Amp worst case loading (12 W) at 100 VAC at 25°C (77°F)	Captured wire	18 to 14 AWG (0.8 to 2.1 mm <sup>2</sup> )
P24 Option	20 - 60 VDC ±10%	0.6 Amp worst case loading (12 W)		

 **NOTE**

If the meter is used to perform control functions or monitor power quality and power disruption events, an Uninterruptable Power Supply (UPS) should be used to ensure constant supply power.

---

## Power Supply Connections

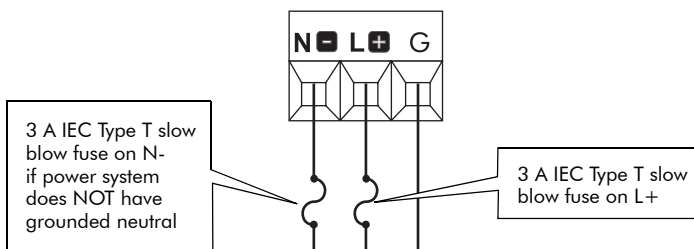

## Step 7: Power Up the Meter

Before you apply power to the meter, ensure that ground is securely connected and that the supply voltage is within the allowed range of the meter's power supply. Power up the meter.

## Step 8: Set Up the Meter Using the Front Panel

Before the meter can operate and communicate correctly, the meter's Power Meter module and Communications modules must be properly configured. Use the Quick Setup Menu.

### Using the Quick Setup Menu

1. Access the menu by pressing the round button twice while the meter is displaying power system data.
2. Scroll down the Setup menu and highlight QUICK SETUP. Press the round button to select.
3. Use the arrow buttons to scroll the list of registers until you highlight the setting you want to change. Press the round button to edit the value of the register.
4. Change the value of the register using the arrow buttons either by selecting a new value from a menu, or changing the digits of a number. Press the round button to save the new setting to the register.
5. Once you make a change to any setup register, the meter will prompt you for a password. Once you have entered the password, confirm the change of the register by selecting YES when prompted.

# Configurable Settings from the Quick Setup Menu

Menu	Setting	Description	Range (Values)	Default
<b>Power Meter</b>	Volts Mode	The power system's configuration – WYE, DELTA, etc.	4W-WYE DELTA SINGLE DEMO 3W-WYE DIRECT-DELTA	4W-WYE
	PT1 (Primary)	The Potential Transformer's primary winding voltage rating	1 to 999,999,999	347
	PT2 (Secondary)	The Potential Transformer's secondary winding voltage rating	1 to 999,999,999	347
	CT1 (Primary)	The Current Transformer's primary winding current rating	1 to 999,999,999	5
	CT2 (Secondary)	The Current Transformer's secondary winding current rating	1 to 999,999,999	5
	V1 Polarity	The polarity of the Potential Transformer on V1	Normal or Inverted	Normal
	V2 Polarity	The polarity of the Potential Transformer on V2	Normal or Inverted	Normal
	V3 Polarity	The polarity of the Potential Transformer on V3	Normal or Inverted	Normal
	I1 Polarity	The polarity of the Current Transformer on I1	Normal or Inverted	Normal
	I2 Polarity	The polarity of the Current Transformer on I2	Normal or Inverted	Normal
I3 Polarity	The polarity of the Current Transformer on I3	Normal or Inverted	Normal	
<b>Comm 1</b>	COM1 Unit ID	Every meter on an RS-485 network must have a unique Unit ID number	1 to 9999	From serial number <sup>1</sup>
	COM1 Baud Rate <sup>2</sup>	The data rate, in bits per second	1200, 2400, 4800, 9600, 19200	9600
	COM1 Protocol	The communications protocol	ION, ModemGate <sup>3</sup> , Modbus RTU, DNP 3.00, Factory	ION
<b>Comm 2</b>	COM2 Unit ID	Every meter on an RS-485 network must have a unique Unit ID number	1 to 9999	From serial number <sup>1</sup>
	COM2 Baud Rate <sup>2</sup>	The data rate, in bits per second	1200, 2400, 4800, 9600, 19200	9600
	COM2 Protocol	The communications protocol	ION, EtherGate <sup>4</sup> , Modbus RTU, DNP 3.00, Factory	ION
<b>Infrared Comm</b>	IR1 Unit ID	The Unit ID for the Infrared port	1 to 9999	From serial number <sup>1</sup>
	IR1 Baud Rate	The data rate, in bits per second, for the Infrared port	1200, 2400, 4800, 9600, 19200	9600
	IR1 Protocol	The communications protocol for the Infrared port	ION, Modbus RTU, DNP 3.00, Factory, Infrared I/O	ION

Menu	Setting	Description	Range (Values)	Default
Ethernet	ETH1 IP Address	The Network IP Address of the meter - see your Network Administrator	000.000.000.000 to 999.999.999.999	none
	ETH1 Subnet Mask	Used if subnetting applies to your network- see your Network Administrator	000.000.000.000 to 999.999.999.999	none
	ETH1 Gateway	Used in multiple network configurations- see your Network Administrator	000.000.000.000 to 999.999.999.999	none
	ETH1 SMTP Server	Sets the IP Address for the SMTP Mail Server that is configured to forward mail from the meter	000.000.000.000 to 999.999.999.999	none
	ETH1 SMTP Connection Timeout	Sets the minimum time that the meter waits for a connection to an SMTP server	0 to 9999	60 seconds
Profibus Comm	CM4 PB Address <sup>5</sup>	Unique ID for Profibus network.		126
Sag/Swell <sup>7</sup>	Swell Lim	The limit a monitored voltage must exceed in order for the meter to classify it as an overvoltage condition <sup>6</sup>	0 to 9999	106
	Sag Lim	The limit a monitored voltage must fall below in order for the meter to classify it as an undervoltage condition <sup>6</sup>	0 to 999	88
	Nom Volts <sup>8</sup>	The primary power system voltage (L-L voltage for Delta systems, and L-N voltage for Wye systems)	0 to 9,999,999	0

## Notes

- <sup>1</sup> The factory set Unit ID for this port is based on the serial number of the meter. For example: Serial number: PABC-0009A263-10; Unit ID: 9263.
- <sup>2</sup> All devices connected to the each port must communicate at the same baud rate as this port.
- <sup>3</sup> ModemGate is available on ION7330 and ION7350 meters with an internal modem.
- <sup>4</sup> EtherGate is available on ION7330 and ION7350 meters with Ethernet.
- <sup>5</sup> Profibus protocol is an option on ION7300 meters. You can only change the Profibus address via the front panel, not through software.
- <sup>6</sup> The ANSI C84.1 1989 standard recommends a temporary overvoltage limit of 106% for Range B voltage levels, and a temporary undervoltage limit of 88% for load voltages and 92% for the service entrance.
- <sup>7</sup> Sag/Swell is available on ION7350 meters.
- <sup>8</sup> The Nom Volts setup register MUST be set to your primary power system voltage, or the Sag/Swell feature will not properly function.



---

## Additional Menus

- ◆ **Clear Functions:** allows you to reset cumulative parameters, such as Peak Demand, Min/Max and Energy.
- ◆ **Adv Meter Setup:** access to every ION register in the meter.
- ◆ **Display Setup:** allows you to change display settings such as Contrast, Backlight Timeout and Auto Scroll.
- ◆ **Screen Setup:** allows you to change data displayed on the display screens.
- ◆ **Nameplate Info:** displays information about the meter options, such as Serial Number, Battery Life and Meter Firmware Revision.
- ◆ **Security:** allows you to modify the meter's password.
- ◆ **Diagnostics:** provides information to assist with meter installation and troubleshooting.

## Navigating Menus

Each menu has a title displayed at the top of the display screen and menu items displayed below the title.

Button	Function
	Scrolls up through menu items.
	Scrolls down through menu items.
	Selects a highlighted item. Select RETURN to go back to the previous screen.

## Editing Registers

For numeric registers, the  cursor indicates the number being edited.









For enumerated registers, the current value of the register will be displayed in the list with an asterix (\*) on either side.



## Password Security

The password is required when you make a change to a register. The password is factory set at '00000' (5 zeros).

Button	Function
	<ul style="list-style-type: none"> <li>◆ Numeric Register: Increases value of register.</li> <li>◆ Enumerated Register: Moves up in list.</li> </ul>
	<ul style="list-style-type: none"> <li>◆ Numeric Register: Decreases value of register.</li> <li>◆ Enumerated Register: Moves down in list.</li> </ul>
 Press and hold for 1 second	Moves the position of the cursor  to the right.
 Press and hold for 1 second	Moves the position of the cursor  to the left.
	Enters the new value.

### NOTE

After you enter the new value by pressing the round button, a verification screen appears. Select YES to confirm the change or NO to cancel the change and return to the previous screen.

## Step 9: Verify Meter Operation

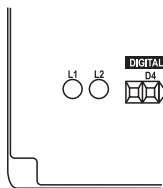

L1 and L2 LEDs are located on the meter backplate.

- ◆ L1 is factory-configured to pulse once for every 1.8 Wh of energy measured.
- ◆ L2 blinks slowly to indicate CPU operation. It blinks rapidly to indicate communications through one of its serial ports. If the L2 LED does not blink once the meter is installed, contact Technical Support.

### Verifying Ethernet Communications

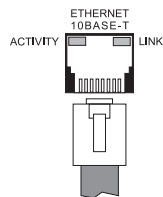

Two LEDs, Activity and Link, are next to the Ethernet port on the side of the meter.

- ◆ LINK remains on while an Ethernet carrier is present; if this LED is off, the Ethernet connection cannot be established.
- ◆ ACTIVITY blinks to indicate Ethernet traffic.

### Verifying Profibus Communications

Two LEDs are adjacent to the Profibus port on the meter's backplate.

- ◆ DE indicates communications between the Profibus Master and the meter have been established.
- ◆ PWR is on to show that the meter is powered.



## **PowerLogic ION7300 Series Installation Guide**

For further assistance  
please contact us at:

### **Schneider Electric**

Power Monitoring and Control  
2195 Keating Cross Road  
Saanichton, BC  
Canada V8M 2A5  
Tel: 1-250-652-7100

295 Tech Park Drive, Suite 100  
Lavergne, TN 37086  
USA  
Tel: 1-615-287-3400

Electropole (38 EQI)  
31, rue Pierre Mendès France  
F - 38050 Grenoble Cédex 9  
Tel : + 33 (0) 4 76 57 60 60

Getting technical support:  
Contact your local Schneider Electric sales  
representative for assistance or go to the  
[www.powerlogic.com](http://www.powerlogic.com) website.

Electrical equipment should be installed, operated,  
serviced, and maintained only by qualified personnel.  
No responsibility is assumed by Schneider Electric for any  
consequences arising out of the use of this material.

70002-0198-06  
© 2006 Schneider Electric. All rights reserved.  
July 19, 2006