

# Gain energy insight and control with PowerLogic™

PowerLogic ION7300 series

power and energy meter

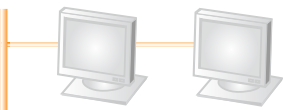



Financial management including accounting and billing

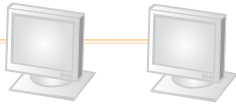

Facility and energy management

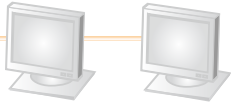

Operations management including engineering, planning and maintenance

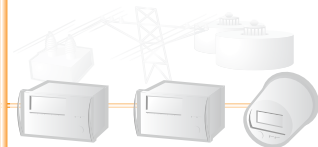

Power generation, transmission and distribution



Service entrances and onsite generation



Power mitigation and main power distribution equipment



PDUs and data servers



Tenants, departments or subcontractors

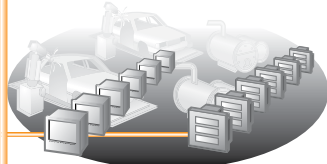

Processes, lines, machines or equipment

## Features

### Measurements

Bidirectional, absolute, and net energy measurements. Rolling block, predicted, and thermal demand. Individual and total harmonic distortion up to the 31st. Advanced logic and mathematical functions.

### Internet-enabled communications

Two RS-485 ports, infrared data port standard. Optional built-in modem with ModemGate allows modem access for 31 other devices. Optional Ethernet port with EtherGate allows direct Ethernet-to-RS-485 data transfer to 31 other devices. Modbus RTU, Modbus TCP, DNP 3.0, and PROFIBUS DP. Call-back feature offers fast alarm response. WebMeter and MeterM@il® allow distribution of metered data and alarms over the Internet.

### Interoperability

Communicate via multiple protocols to add to existing Modbus, DNP or ION Enterprise networks. Logs and real-time values are available via Modbus. These meters are supported by UTS MV-90® via serial and Ethernet.

### On-board data logging

Scheduled or event-driven logging of up to 96 parameters. Sequence-of-events and min/max logging.

### Setpoints for control and alarms

Use logical operators and setpoints to configure alarms, define basic control algorithms, and implement back-up protection. Setpoints can trigger data logging, digital outputs, pulse outputs, clearing and reset functions, call-back (ION7350).

### Logic and math

Sophisticated logic and mathematical functions to perform on-board calculations on any measured value (ION7330, ION7350).

### Inputs and outputs

Four digital inputs for status/counter functions. Four digital outputs for control/pulse functions. Optional analogue inputs and outputs.

### Front panel display

Easy to read backlit LCD with adjustable contrast, supporting eight customisable data displays (scrolled automatically or manually) and basic setup.

PowerLogic ION7300 with remote modular display





## PowerLogic ION7300 series

Schneider Electric PowerLogic ION7300 series meters offer unmatched value, functionality, and ease of use. Used in enterprise energy management applications such as feeder monitoring and sub-metering, PowerLogic ION7300 series meters interface with ION Enterprise software or other power management or automation systems to provide users with real-time information for monitoring and analysis.

The meter is available in three models, with incremental features sets and a variety of options. PowerLogic ION7300 meters are an ideal replacement for analogue meters, while also providing a multitude of power and energy measurements, analog and digital I/O, communication ports and industry-standard protocols. The ION7330 meter adds on-board data storage, emails of logged data, and an optional modem. The ION7350 meter is further augmented by more sophisticated power quality analysis, alarms and a call-back-on-alarm feature. Refer to the detailed descriptions within for a complete list of feature availability.

## Applications

### For infrastructure, industrials and buildings

- Energy efficiency and cost
  - Sub-bill tenants for energy costs
  - Allocate energy costs to departments or processes
  - Reduce peak demand surcharges
  - Reduce power factor penalties
- Power availability and reliability
  - Verify the reliable operation of equipment
  - Improve response to power quality-related problems
  - Leverage existing infrastructure capacity and avoid over-building
  - Support proactive maintenance to prolong asset life

### For electric utilities

- Power availability and reliability
- Improve T&D network reliability
- Enhance substation automation
- Maximise the use of existing infrastructure
- Analyse and isolate the source of power quality problems

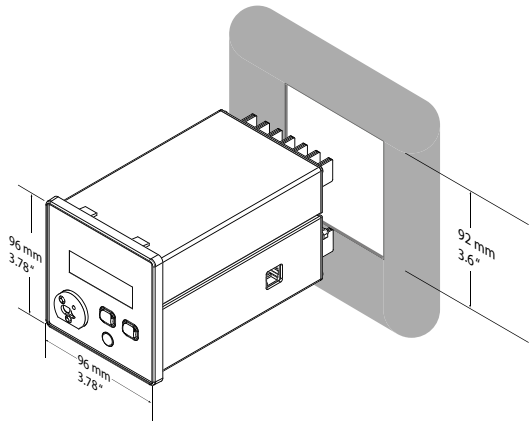

#### Switchboard draw-out cases

Complete switchboard hardware kit (internal cage with external casing) or "retrofit" kit for existing GE S1 or ABB FT21 switchboard cases.

FT21 supports D4B-7F (in Delta volts mode) or D4B-3F (in 4-wire Wye volts mode).

#### Relay extension board

Optional Digital Output Extension Board extends the meter's output capabilities with additional relay options (contact Schneider Electric for details).

## Installation

Standard PowerLogic ION7300 series meters with integrated display are designed to fit into DIN standard 92 X 92 mm (3.62 x 3.62 in.) cutout. Simply slide the mounting bars into the grooves on either side of the unit. The TRAN option provides a base unit without display that can be mounted either flush against any flat surface in whichever orientation is most convenient; attached to any standard DIN rail (requires optional DIN rail mount); or installed in a cutout (as the standard model). The remote modular display (RMD) can be mounted as the standard unit. A 1.8 m (6 ft.) cable is supplied.

4-wire Wye, Delta, 3-wire Wye, Direct Delta and single phase systems. 3 voltage and 3 current inputs. No PTs required on voltage inputs for Wye systems up to 347/600 V ac and Delta systems up to 600 V ac. All inputs pass ANSI/IEEE C37.90.1-1989 surge withstand and fast transient tests.

Input(s)	Specifications
<b>Voltage inputs</b>	
Inputs	U1, U2, U3, Uref
Rated inputs1	50 to 347 L-N (87 to 600 L-L) V ac rms (3-phase systems) 50 to 300 L-N (100 to 600 L-L) V ac rms (single-phase systems)
Overload	1500 V ac rms continuous
Input impedance	> 2 M per phase (phase-vref)
<b>Current inputs</b>	
Inputs	I1, I2, I3
Rated inputs	10 A rms (+ 20% maximum, 300 V rms to ground)
Overload	20 A continuous
Dielectric withstand	500 A for one second (non-recurring)
Burden	0.0625 VA @ 10 Amps
<b>Control power</b>	
Operating range	Standard model: 95 to 240 V ac $\pm$ 10% (47 - 440 Hz); DC: 120 to 310 V dc $\pm$ 10% P24 option: 20 to 60 V dc $\pm$ 10%
<b>Current transformers</b>	
Compatibility	5 A nominal, 10 A full-scale secondaries.
Primary CT rating	Equal to current rating of the power feed protection device.2
Secondary CT burden capacity	> 3 VA

1 Accuracy may be affected if the voltage on V1 falls below 50.

2 If the peak anticipated load is considerably less than the rated system capacity, you can improve accuracy and resolution by selecting a lower rated CT.



PowerLogic ION7350

## Front panel

Easy to read backlit LCD with adjustable contrast. LCD supports local data display and basic setup. Remote display option to 1.8 m (6 ft) from base unit. Eight data display screens (kWh net, kWh swd / mx, Volts, Amps, Power, Frequency, V-THD, I-THD) can be customised through the communications port to show chosen parameters, and scrolled manually or automatically. The front panel can display up to nine digits of resolution for numeric values. Four display formats are available: 4 parameter, to single-parameter large character displays. Customer-designed parameter labels are programmable via PowerLogic ION Enterprise software.

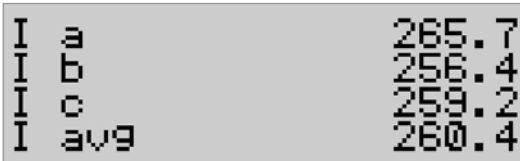

Example meter display formats.

## Power and energy measurements

Fully bi-directional, 4-quadrant, revenue-accurate or revenue-certified energy metering. They can replace discrete energy meters, demand meters and pulse initiators, and perform a wide range of other metering and instrumentation functions.

Supports thermal demand and sliding window (rolling block) demand. Factory-configured to calculate average current demand and kW, kvar and kVA demand. User-configurable time intervals for demand calculations and sensitivity settings.

Measurement specifications <sup>1</sup> (at 50.0 Hz and 60.0 Hz at 25° C / 77° F)	Accuracy 1 (%rdg + %fs <sup>2</sup> )
Voltage	0.25% + 0.05%
Current	0.25% + 0.05%
Power, real (kW)	0.5% reading
Energy, real (kWh)	0.5% reading <sup>3</sup>
Power, apparent (kVA)	0.5% + 0.1%
Energy, apparent (kVAh)	1.0% reading
Power, reactive (kvar) > 5 % FS	1.5% reading
Energy, reactive (kvarh)	1.5% reading
Power factor (at unity PF)	1.5% reading
Frequency U1,U2,U3 (42-69 Hz): per phase, total	±0.01 Hz

Display resolution meets or exceeds accuracy.

1 50 V ac to 347 V ac + 25 %

2 % full scale voltage and current. Accuracy specifications comply with IEC 60687 Class 0.5 and ANSI 12.20 Class 0.5 at 25°C (77°F)

3 Register bounds 0 to ± 3.3x10<sup>7</sup> (kW) and 0 to ± 1038 (kWh)

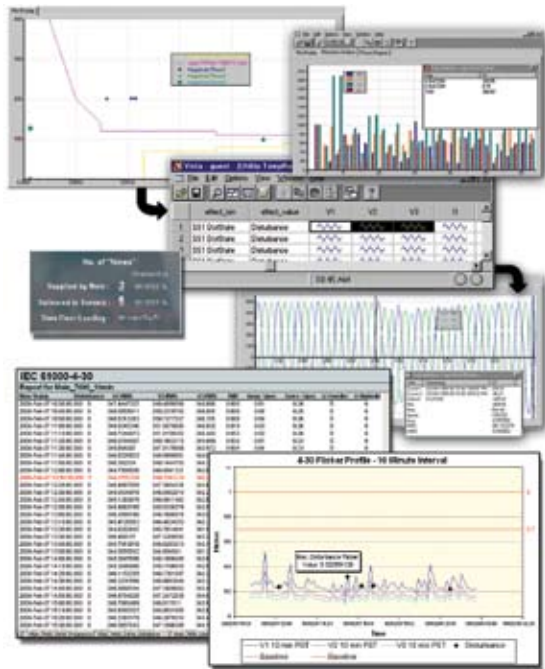

Example from PowerLogic ION Enterprise software showing continuous, wide-area monitoring, data capture and reporting for power quality and reliability conditions.

## Power quality

Use meter data to help uncover the sources of harmonics and voltage sags/swells. Analyse problems and avoid repeat interruptions.

- Harmonics (all models): individual harmonics, even, odd, total up to 15th (31st on ION7350). Total harmonic distortion: 1% Full Scale. I4 derivation. 1% reading + 0.2% unbalanced. K Factor: 5.0 % Full Scale.
- Sag/swells (ION7350 only): monitors applicable phase voltages for temporary undervoltages and overvoltages (i.e. CBEMA Type 2 and Type 3 disturbances). Voltage waveforms for sags and swells; report on each disturbance magnitude and duration.
- Sampling rate (all models): Up to 32 samples per cycle (64 on ION7350).
- Waveform (digital fault) recording (ION7350 only): Simultaneous event capture on all channels, up to 48 cycles each. Resolution: 64 samples per cycle; maximum number of cycles for contiguous waveform capture: 6,900 (16 samples/cycle x 48 cycles). depth of 3, the interval is triggered on demand.

## Example log configurations

Waveform recording settings

Meter	Event	Data	Channel	Samples/ channel	Cycles	Record	Days
7330	500	A	-	-	-	-	29
	500	B	-	-	-	-	118
	500	C	-	-	-	-	96
	500	D	-	-	-	-	383
7350	500	A	6	32	12	3	28
	500	B	6	32	12	3	111
	500	C	6	16	48	3	26
	500	D	6	64	16	3	331

A 16 parameters recorded every 15 minutes

B 16 parameters recorded hourly

C 4 parameters recorded every 15 minutes

D 4 parameters recorded every hour

## Data and event logging (ION7330, ION7350)

Ships with a comprehensive data-logging configuration. Data is prioritised and stored onboard in nonvolatile memory to eliminate data gaps in the event of outages or server downtime. Retrieved data is stored in an ODBC-compliant database when using ION Enterprise. Logs various power system data such as energy and demand, or the average power system quantity used over a period of time (Historic Mean Log). Standard memory capacity for both meters is 304 kilobytes. Default logging depth is set for 930 records.

- Historic log: record any combination of measurements at scheduled intervals by setpoints or logic conditions. Configure for up to 30 days of recording capacity at 15 minute intervals. Default depth of 930, interval of 900 seconds (15 minutes).
- Min/Max log: on any parameter, over any time interval (e.g. daily, monthly). Easily record other values coinciding with the new minimum or maximum. Defaults: min and max for all basic power parameters.
- Report Generator log (EgyDmd Log): Default depth and interval.
- Sag/Swell log (ION7350 only): Detect sags, swells on any voltage channel and record instantaneous values and waveforms. Depth of 100; interval triggered on demand.
- Event log: Depth of 50; interval triggered on demand.

### Time of use (TOU)

2-year internal calendar with up to 15 daily tariff profiles. Programmable triggers. Separate energy and demand accumulators.

### Event priorities and alarming

Configurable event priorities allow you to define alarm conditions. Sequence-of-events time-stamped to  $\pm 10$ ms accuracy. Time-stamped record of all configuration changes, setpoint and min/max events.

## Inputs and outputs

All meter models: four digital outputs, one infrared data port, one configurable LED output. Four digital status inputs standard on ION7330 and ION7350 meters. Optional analogue I/O ports can be used to monitor flow rates, RPM, fluid levels, oil pressures and transformer temperatures. Output real-time power to an RTU or perform equipment control operations.

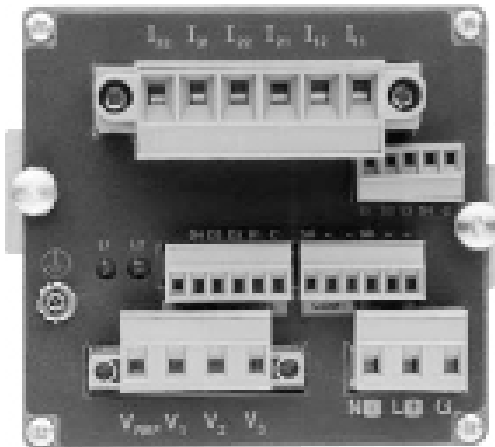

### EtherGate and ModemGate

The meters can provide gateway functionality depending on communication options.

EtherGate: provides access from an Ethernet network using Modbus TCP protocol to devices connected to the meter's serial ports.

ModemGate: provides access from the telephone network to devices connected to the meter's serial ports.

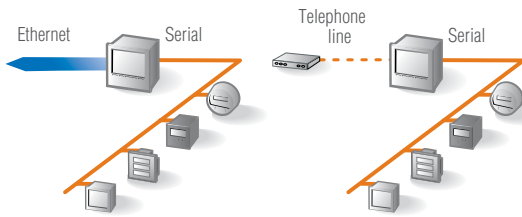

### Internet connectivity

XML: to integrate with custom reporting, spreadsheet, database, and other applications.

WebMeter: an on-board web server, provides access to real-time values and PQ data through any web-enabled device and even supports basic meter configuration tasks.

MeterM@il: automatically emails user-configured, high-priority alarm notifications or scheduled system-status update messages to anyone, anywhere within the facility or around the world.

## Communications

Multiple communication ports that operate simultaneously allow the meters to be used as part of a power and energy management system and to interface with other automation systems. Upload waveforms, alarms, billing data, and more to software for viewing and analysis.

Port	Specifications
RS-485 ports	ION7300 has a single RS-485 port. ION7330 and ION7350 meters can have two RS-485 ports. Supports DNP 3.0
Infrared data port	Front panel optical port. Compatible with an ANSI Type 2 magnetic optical communications coupler. Data rates up to 19,200 bps.
Ethernet port (optional)	Optional 10Base-T port for direct access to metering information via Ethernet LAN/WAN. EtherGate (data transfer between Ethernet and RS-485). <sup>1</sup>
PROFIBUS port (optional ION7300 only)	PROFIBUS DP standard protocol support via sub-D 9 pin female connector.
Internal modem (ION7330, ION7350)	Data rates from 300 bps to 33,600 bps. ModemGate (data transfer between modem and RS-485). <sup>2</sup> Compatible with power monitoring software that supports Modbus RTU, ION or DNP 3.0 RJ-11 or a captured wire connector. The ION7350 meter is offered with a call-back feature for quick alarm response.

<sup>1</sup> The meter COM2 port functions as a dedicated EtherGate port (RS-485 Master) on ION7330 and ION7350 meters with the Ethernet option  
<sup>2</sup> The meter COM1 port functions as a dedicated ModemGate port (RS-485 Master) on ION7330 and ION7350 meters with the internal modem option

## Software integration

PowerLogic ION7330 and ION7350 can communicate via multiple protocols to extend existing Modbus, DNP or ION Enterprise networks. Logs and real-time values are available via Modbus. Meters supported by UTS MV-90<sup>®</sup> via serial and Ethernet. Integrate within PowerLogic facility-level or enterprise-wide power and energy management systems. Real-time data and data logs stored onboard can be automatically retrieved on a scheduled basis for analysis at the system level. Compatible with PowerLogic ION Enterprise and PowerLogic ION Setup.

## Special features

Flash-based firmware allows upgrades via communications without removing the meter from the site. Simply download the latest firmware from [www.powerlogic.com](http://www.powerlogic.com).

## General specifications

Description	Specifications
Accuracy	IEC 60687 class 0.5S; ANSI C12.16; ANSI class 10, (5 A nominal, 10 A max); OFGEM approved (UK)
Safety/construction	IEC 1010-1; CE marked; UL: Certified to UL 3111; CAN/CSA C22.2 No. 1010-1
Electromagnetic compatibility	EN 55014-1:1993; EN 61000-4-4; EN 60687:1993 for immunity to electromagnetic HF fields; EN 60687:1993 for immunity to electrostatic discharges. Analog I/O: each analog I/O pin passes IEC 61000-4-4 (4 kVp-p @ 2.5 kHz for 1 min).
Surge withstand	All inputs pass ANSI/IEEE C37.90-1989 surge withstand and fast transient tests
Environmental conditions	Operation: -20° C to +60° C (-4° F to +140° F) ambient air; Storage: -30° C to +85° C (-22° F to +185° F) Humidity: 5 % to 95 % non-condensing; FCC: Part15, FCC Rules for Class A Digital Device (emissions)

Features and options			
<b>Metering</b>			
Power, energy and demand	■	■	■
<b>Power quality</b>			
Dip/swell monitoring			■
Harmonics: individual, even, odd, up to	15 <sup>th</sup>	15 <sup>th</sup>	31 <sup>st</sup>
Sampling rate, maximum samples per cycle	32	32	64
<b>Logging and recording</b>			
Standard memory		300 kB	300 kB
Min/max logging for any parameter	■	■	■
Historical logs, maximum # of channels		32	96
Waveform logs, maximum # of cycles			48
Timestamp resolution in seconds		0.001	0.001
<b>Communications and I/O</b>			
RS-485 ports	1	2	2
Ethernet/infrared optical ports	1/1	1/1	1/1
Internal modem		1	1
PROFIBUS DP port	1		
DNP 3.0 through serial, modem, and i/r ports		■	■
Modbus RTU slave on serial, modem, and i/r ports	■	■	■
Modbus TCP through Ethernet port	■	■	■
EtherGate data transfer between Ethernet & RS-485		■	■
ModemGate data transfer between internal modem & RS-485		■	■
MeterM@il, logged data alarms via email <sup>1</sup>		■	■
WebMeter, onboard web server	■	■	■
Analog inputs/analog outputs	4/4	4/4	4/4
Digital status inputs/counter		4	4
Digital relay outputs	4	4	4
<b>Setpoints, alarming, and control</b>			
Setpoints, number/minimum response time		1 sec	1 sec
Math, logic, trig, log, linearisation formulas		■	■
Single & multi-condition alarms		■	■
Call-out on alarms			■
<b>Other metering functions</b>			
MV-90 on serial, Ethernet ports		■	■
Multi-year scheduling: hourly activity profiles		■	■

<sup>1</sup> ION7800 and ION7350 models only.



The 2007 award recognizes Schneider Electric for its technological advancements and wide product range in the field of power quality (PQ) and energy management solutions. In total, this is the fourth award that Schneider Electric and [recently acquired] Power Measurement have received from Frost & Sullivan in recognition of achievements in this arena.

Prithvi Raj, Frost & Sullivan research analyst



Certificate No. 002188

Please contact your local sales representative for ordering information.

Visit [www.powerlogic.com](http://www.powerlogic.com) for more information on other PowerLogic products, applications and system solutions.

Schneider Electric  
 35 Rue Joseph Monier  
 CS 30323  
 92506 Rueil Malmaison Cedex  
 Tel : +33 (0)1 41 29 70 00  
 Fax : +33 (0)1 41 29 71 00  
<http://www.schneider-electric.com>  
<http://www.PowerLogic.com>

As standards, specifications and designs develop over time, ask for confirmation of the information given in this publication. PowerLogic, System Manager, Modbus, ION and ION Enterprise are either trademarks or registered trademarks of Schneider Electric. © 2008 - Schneider Electric - All rights reserved

Printed on recycled paper

Publishing : Schneider Electric  
 Production : Schneider Electric PMC  
 Printing : Imprimerie du Pont de Claix - made in France