

PowerLogic power-monitoring units

# ION6200

Technical data sheet

2007



# ION6200

## Functions and characteristics

PE66078



PowerLogic® ION6200.

The ION6200 meter offers outstanding quality, versatility, and functionality in a low-cost, ultra-compact unit. The meter is simple to use and offers a big, bright LED display for superior readability in poor lighting conditions.

Complete with four-quadrant power, demand, energy, power factor, and frequency measurements, this versatile unit is easy to wire and mount. It offers an excellent upgrade path that lets you start with a low-cost base model and add enhanced functionality over the long term.

The ION6200 meter lets you upgrade functionality in the field by activating the base unit. Rather than carry a large inventory of pre-configured meters, genset and electrical equipment manufacturers, panel shops, EMS manufacturers and energy service providers can each adapt meter functionality to specific applications as required.

### Applications

- Class 0.5S metering and sub-metering.
- Replace multiple analog meters.
- Basic metering.
- Cost allocation.
- Substation monitoring.

### Main characteristics

#### High visibility front panel display

The ION6200 displays all basic power parameters on a bright LED display with twelve 19 mm high digits.

#### Complete communications

Optional RS 485 port with standard Modbus RTU and ION compatible protocol; data rates from 1,200 bps to 19,200 bps.

#### Modularity

The ION6200's modular construction allows for simple retrofit, allowing you to save money by making a low initial investment that can be upgraded to meet future needs.

#### Easy to use

Fast setup via display or software; free configuration software; and a bright, easy to read LED display make the ION6200 easy to use.

#### Accuracy certification

This meter offers IEC 60687 Class 0.5S accuracy for use as a tariff meter.

#### Flexible architecture

Patented ION® technology provides a modular, flexible architecture that offers extensive user programmability. It uniquely addresses complex monitoring and control applications, and adapts to changing needs, avoiding obsolescence.

### Part numbers

#### PowerLogic® ION6200 meters

PowerLogic® ION6200

M6200

See page 5 for part number descriptions and options.

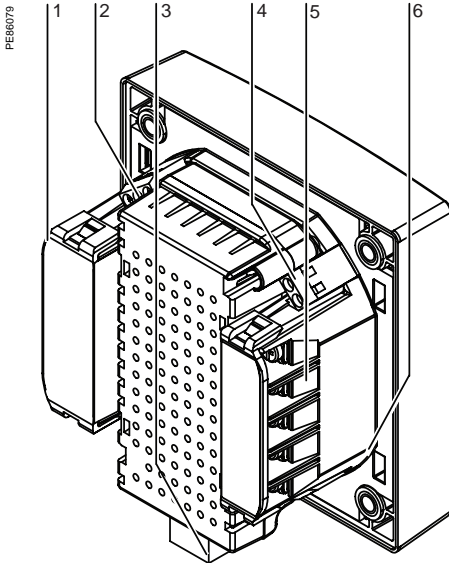

- 1 Current inputs
- 2 COM1 port
- 3 Power supply
- 4 D2: Form A digital out
- 5 Voltage inputs
- 6 D1: Form A digital out

Selection guide		ION6200 Standard	ION6200 EP #1*	ION6200 EP #2*
General		(N)	(P)	(R)
Use on LV and HV systems		■	■	■
Current and voltage accuracy <sup>(1)</sup>		0.3%	0.3%	0.3%
Energy and power accuracy		0.5%	0.5%	0.5%
Number of samples per cycle		64	64	64
Instantaneous RMS values				
Current, voltage, frequency		■	■	■
Active, reactive, apparent power	Total	-	■	■
	per phase	-	-	■
Power factor	Total	-	■	■
	per phase	-	-	■
Energy values				
Active, reactive, apparent energy		-	■	■
Settable accumulation modes		-	■	■
Demand values				
Current	Present and max.	-	■ <sup>(3)</sup>	■
Active, reactive, apparent power	Present and max.	-	■ <sup>(4)</sup>	■
Predicted active, reactive, apparent power		■	■	■
Power quality measurements				
Harmonic distortion	Current, voltage	■	■	■
Display and I/O				
LED display		■	■	■
Pulse output		-	■	■
Direct voltage connection (VAC)		400/690	400/690	400/690
Communication				
RS-485 port		■	■	■
ION compatibility		■	■	■
Modbus RTU protocol		■	■	■

(\*) EP = 'Enhanced package.'

(1) For L-N only. L-L = 0.5% reading accuracy.

(2) Some values not available when Volts Mode is set to Delta or Delta Direct.

(3) Maximum values only.

(4) Not all demand values may be measured. Refer to the ION6200 installation guide for details.



PowerLogic® ION6200.

Electrical characteristics		
Type of measurement		True rms electrical parameters Up to 64 samples/cycle
Measurement accuracy	Current and voltage	0.3% reading
	Power	IEC 60687 Class 0.5 ANSI 12.20 Class 0.5 (0.5% reading)
	Frequency	0.1% reading
	Power factor	1.0% reading
	Energy	IEC 60687 Class 0.5 ANSI 12.20 Class 0.5 (0.5% reading)
Input-voltage characteristics	Measured voltage	60-400 LN (103.5-690LL) VAC RMS (3 phase) 60-400 LN VAC (single phase)
	Measurement range	60-400 LN VAC
	Impedance	2 MΩ /phase
	Inputs	V1, V2, V3, Vref
	Overload	1500 VAC RMS continuous
	Dielectric withstand	>3250 VAC RMS; 60 Hz for 1 minute
Input-current characteristics	Rated Inputs	10 A RMS (+20% max, 300 V RMS to ground)
	Permissible overload	120 A RMS for 1 second, non-recurring
	Starting current	0.005 A RMS
	Burden	0.05 VA (typical) @ 5 A RMS
	Inputs	I1, I2, I3
	Dielectric withstand	3000 V RMS for 1 minute
Power supply	AC	Standard: 100-240 VAC, 50-60 Hz 480 V: 480 VAC, 60 Hz
	DC	Standard: 110-300 VDC Low Voltage DC: 20 - 60 VDC
Input/outputs	Digital outputs	2 optically isolated digital outputs for KY pulsing or control Max forward current: 150 mA Max voltage: 200 V Max current: 150 mA
	RS-485 port	Optically isolated
Mechanical characteristics		
Weight		0.68 kg (shipping)
Dimensions		Basic unit installed depth: 106.7x106.7x40.6 mm Remote display: 106.7x106.7x22.9 mm
Environmental conditions		
Operating temperature		-20°C to 70 °C ambient air
Storage temperature		-40°C to 85°C
Humidity rating		5% to 95% non-condensing
Pollution degree		2
Installation category		III (Distribution)
Electromagnetic compatibility		
Electrostatic discharge		IEC 61000-4-2 (EN61000-4-2/IEC801-2)
Immunity to radiated fields		IEC 61000-4-3 (EN61000-4-3/IEC801-3)
Immunity to fast transients		IEC 61000-4-4 (EN61000-4-4/IEC801-4)
Surge immunity		IEC 61000-4-5 (EN61000-4-5/IEC801-5)
Conducted immunity		IEC 61000-4-6 (EN61000-4-6/IEC801-6)
Electromagnetic Compatibility for industrial environments		IEC 61000-6-2
Safety		
Canada		CSA C22.2 No. 1010-1 IEC1010-1 (EN61010-1) UL 3111-1
Communications		
RS 485 port		Up to 19 200 bps, Modbus RTU, ION compatible protocol
Firmware characteristics		
Harmonic distortion		Total harmonic distortion ± 1.0%
Display characteristics		
Bright LED display		19 mm high digits Displays all basic power parameters Easy setup for common configuration parameters Password protection on setup parameters Password protection for demand reset

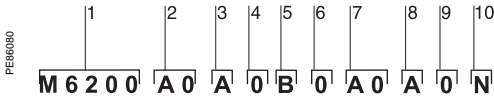

Example product part number.

- 1 Model.
- 2 Form factor.
- 3 Current inputs.
- 4 Voltage inputs.
- 5 Power supply.
- 6 System frequency.
- 7 Communications.
- 8 Onboard inputs/outputs.
- 9 Security.
- 10 Measurement package.

### Part Numbers

Item	Code	Description
1 Model	M6200	ION6200 Meter Kit: ION6200 Meter base, Options Card and Power Supply
2 Form Factor	A0	Integrated display model
	R1	Transducer model with DIN rail mount, Remote Display and 14-ft cable (RJ11, 6 conductor, 26 gauge)
	R2	Transducer model with DIN rail mount, Remote Display and 6-ft cable (RJ11, 6 conductor, 26 gauge)
	R3	Transducer model DIN rail mount, Remote Display and 30-ft cable (RJ11, 6 conductor, 26 gauge)
3 Current Inputs	A	10 Amp current inputs (12 Amp max)
	0	Autoranging (57-400 VAC L-N / 99-690 VAC L-L)
4 Voltage Inputs	0	Calibrated for use with 50 Hz or 60 Hz systems
7 Communications	Z0	No communications
	A0	Single RS-485 port (supports Modbus RTU protocol and ION-compatible PML protocol)
8 I/O	A	No I/O
	B	This option activates the two Form A digital outputs for kWh, kvarh energy pulsing
9 Security	0	No hardware lock (setup is password protected)
	2	RMANSI: Revenue Meter approved for use in the United States (ANSI C12.16 approved; meets ANSI C12.20 class 0.5 accuracy at 23°C; 10A current inputs only)
	3	RMICAN: Measurement Canada approved revenue meter for use in Canada (10A current inputs only)
	4	**RMICAN-SEAL: Factory-sealed and Measurement Canada approved revenue meter
10 Measurement package	N	Standard Measurements (Volts/Amps per phase and avg)
	P	Enhanced Package #1 (Standard Measurements plus Energy/Power total, Frequency, Power Factor total, Neutral Current)
	R	Enhanced Package #2 (all measurements)
<b>Power supply</b>		
Power supply	P620PB	Standard plug-in power supply (100-240 VAC / 50-60 Hz or 110-300 VDC) for the ION6200
	P620PC	Low voltage DC plug-in power supply (20-60 VDC) for the ION6200
	P620PD	480V power supply (480 VAC, 60 Hz) for the ION6200

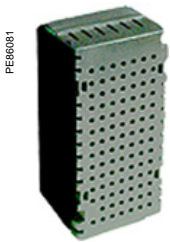



MegaWatt options		
MegaWatt option on meter base with integrated display. Not available for RMICAN or RMICAN-sealed meters		<b>M0</b>
MegaWatt option on Transducer model with DIN rail mount, Remote Display and 14-ft cable (RJ11, 6 conductor, 26 gauge). Not available with Security options RMICAN or RMICAN-SEAL.		<b>N1</b>
MegaWatt option on Transducer model with DIN rail mount, Remote Display and 6-ft cable (RJ11, 6 conductor, 26 gauge). Not available with Security options RMICAN or RMICAN-SEAL.		<b>N2</b>
MegaWatt option on Transducer model with DIN rail mount, Remote Display and 30-ft cable (RJ11, 6 conductor, 26 gauge). Not available with Security options RMICAN or RMICAN-SEAL.		<b>N3</b>

Options card		
1	Standard Measurements	<b>Z0A0N</b>
2	Enhanced Package #1	<b>Z0A0P</b>
3	Enhanced Package #2	<b>Z0A0R</b>
4	Standard Measurements, two pulse outputs	<b>Z0B0N</b>
5	Enhanced Package #1, two pulse outputs	<b>Z0B0P</b>
6	Enhanced Package #2, two pulse outputs	<b>Z0B0R</b>
7	Standard Measurements, RS-485	<b>A0A0N</b>
8	Enhanced Package #1, RS-485	<b>A0A0P</b>
9	Enhanced Package #2, RS-485	<b>A0A0R</b>
10	Standard Measurements, two pulse outputs, RS-485	<b>A0B0N</b>
11	Enhanced Package #1, two pulse outputs, RS-485	<b>A0B0P</b>
12	Enhanced Package #2, two pulse outputs, RS-485	<b>A0B0R</b>

Remote modular display (RMD)		
Model		<b>M620D</b>
Display Type	Standard Display	<b>R</b>
	MegaWatt option - for use with Transducer meter base with MegaWatt option	<b>N</b>
Cable Length	No Cable	<b>0</b>
	14-ft cable for connecting Remote Display Unit to the ION6200 Transducer meter base	<b>1</b>
	6-ft cable for connecting Remote Display Unit to the ION6200 Transducer meter base	<b>2</b>
	30-ft cable for connecting Remote Display Unit to the ION6200 Transducer meter base	<b>3</b>

Cables for remote modular display		
14-ft cable for connecting Remote Display Unit to the ION6200 transducer meter base.		<b>P620C1</b>
6-ft cable for connecting Remote Display Unit to the ION6200 transducer meter base.		<b>P620C2</b>
30-ft cable for connecting Remote Display Unit to the ION6200 transducer meter base.		<b>P620C3</b>

# ION6200 Installation and connections

## ION6200 integrated model dimensions

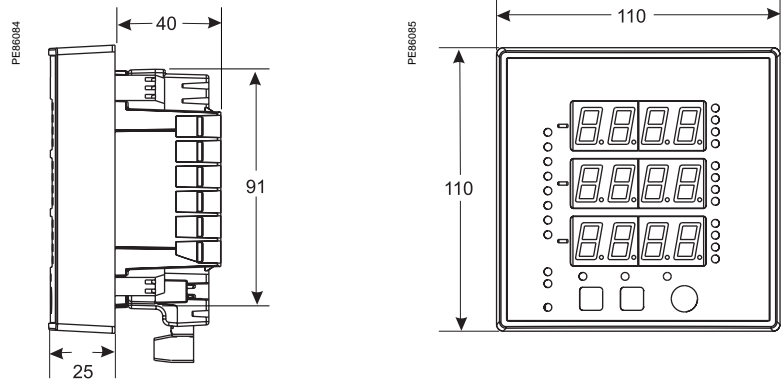

## ION6200 TRAN model dimensions

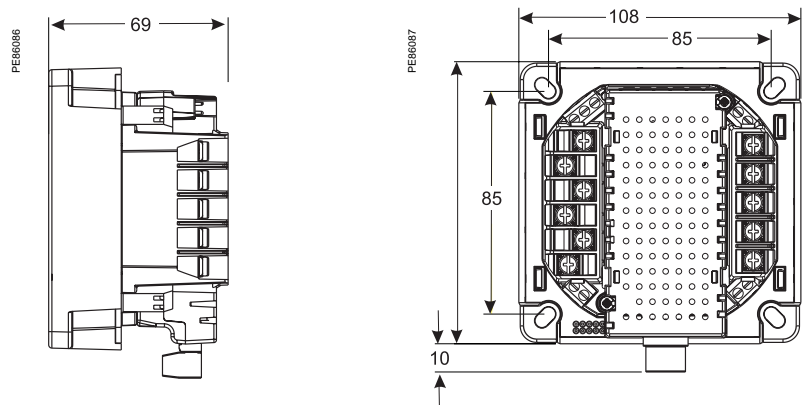

## ION6200 RMD dimensions

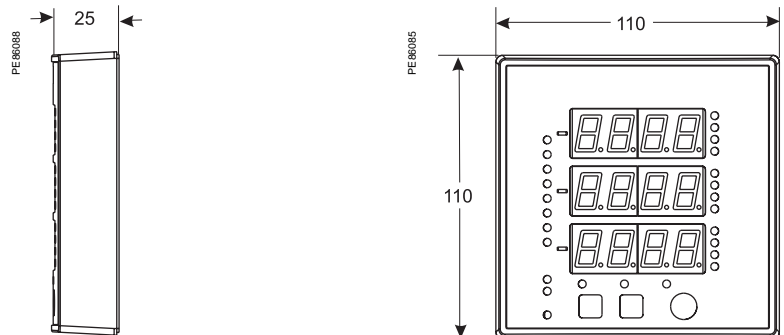

### Mounting integrated model - ANSI 4" (4 1/2" Switchboard)

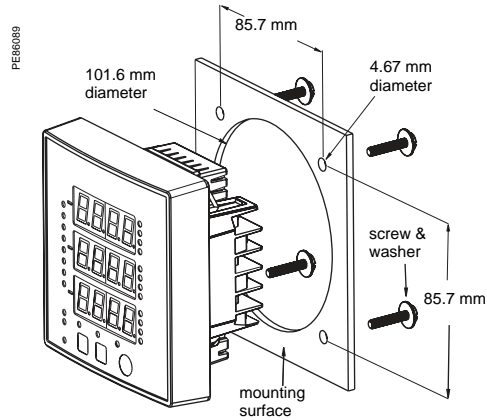

### Mounting integrated model - DIN 96

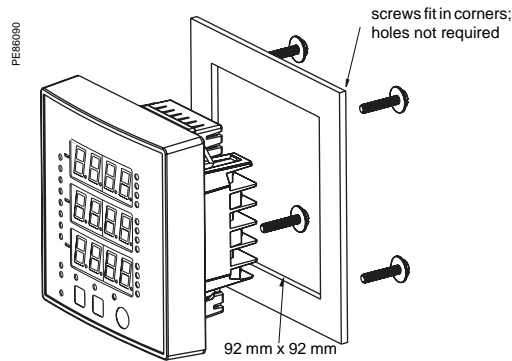

### Mounting the TRAN model

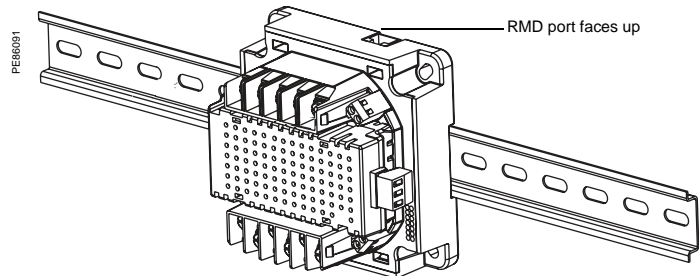

### Typical Form A digital output use

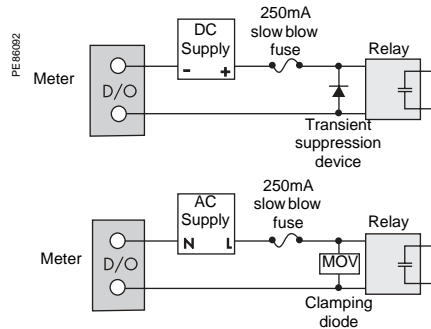

Select an MOV (metal oxide varistor) or clamping diode that ensures the output terminals do not receive voltage greater than 350 V peak during switching.

### 4-Wire Wye, 3-Element direct connection

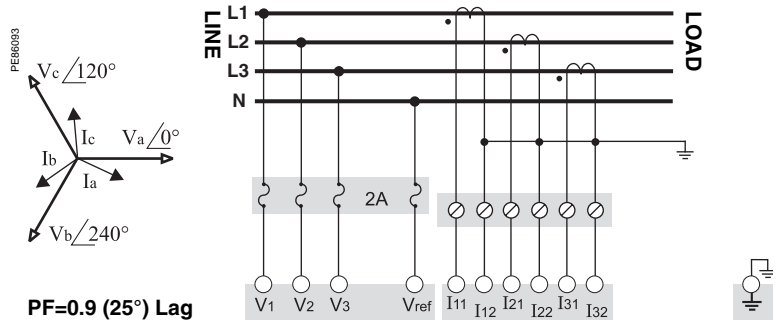

Volts Mode = 4W-Wye

Connection representation only. Other types of connection are possible. Refer to the ION6200 installation guide for details.

### 3-Wire Delta, 2 1/2-Element, 2 PT, 3 CT

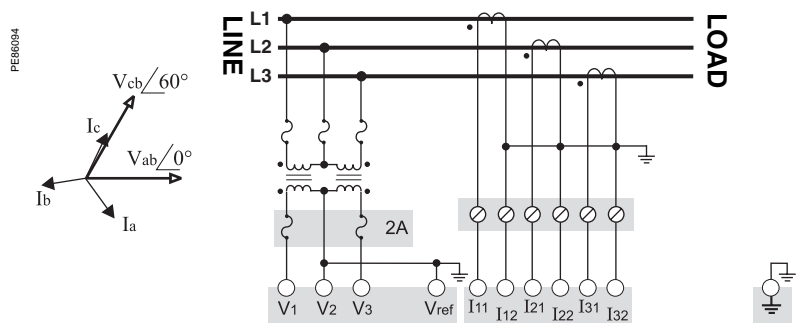

Volts Mode = Delta

Connection representation only. Other types of connection are possible. Refer to the ION6200 installation guide for details.

### Single Phase connection diagram

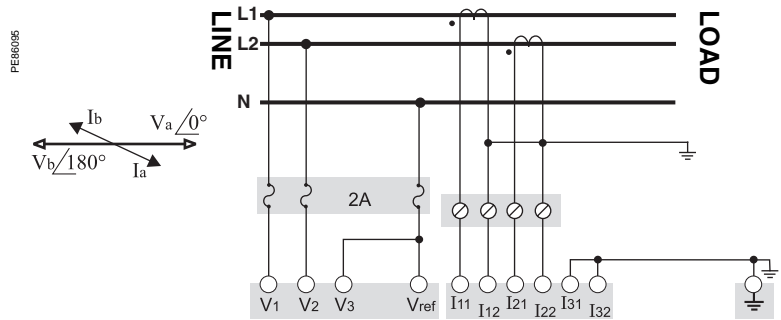

Volts Mode = 2W

Connection representation only. Other types of connection are possible. Refer to the ION6200 installation guide for details.

# Notes

---

# Notes

---

---

**Schneider Electric Industries SAS**

89, boulevard Franklin Roosevelt  
F - 92500 Rueil-Malmaison (France)  
Tél : +33 (0)1 41 29 85 00

<http://www.schneider-electric.com>  
<http://www.merlin-gerin.com>  
<http://www.powerlogic.com>

PLSED306008EN

As standards, specifications and designs develop from time, always ask for confirmation of the information given in this publication. PowerLogic, ION, ION Enterprise, MeterM@il and Modbus are either trademarks or registered trademarks of Schneider Electric.



*This document has been printed  
on ecological paper.*

Publishing: Schneider Electric  
Production: Schneider Electric PMC  
Printing: Imprimerie du Pont de Claix - made in France