

# TLS-4XX Consoles

## Upgrade Installation Instructions

# Notice

---

Veeder-Root makes no warranty of any kind with regard to this publication, including, but not limited to, the implied warranties of merchantability and fitness for a particular purpose.

Veeder-Root shall not be liable for errors contained herein or for incidental or consequential damages in connection with the furnishing, performance, or use of this publication.

Veeder-Root reserves the right to change system options or features, or the information contained in this publication.

This publication contains proprietary information which is protected by copyright. All rights reserved. No part of this publication may be modified or translated to another language without the prior written consent of Veeder-Root.

Contact TLS Systems Technical Support for additional troubleshooting information at 800-323-1799.

## **DAMAGE CLAIMS / LOST EQUIPMENT**

Thoroughly examine all components and units as soon as they are received. If any cartons are damaged or missing, write a complete and detailed description of the damage or shortage on the face of the freight bill. The carrier's agent must verify the inspection and sign the description. Refuse only the damaged product, not the entire shipment.

Veeder-Root must be notified of any damages and/or shortages within 30 days of receipt of the shipment, as stated in our Terms and Conditions.

## **VEEDER-ROOT'S PREFERRED CARRIER**

1. Contact Veeder-Root Customer Service at 800-873-3313 with the specific part numbers and quantities that were missing or received damaged.
2. Fax signed Bill of Lading (BOL) to Veeder-Root Customer Service at 800-234-5350.
3. Veeder-Root will file the claim with the carrier and replace the damaged/missing product at no charge to the customer. Customer Service will work with production facility to have the replacement product shipped as soon as possible.

## **CUSTOMER'S PREFERRED CARRIER**

1. It is the customer's responsibility to file a claim with their carrier.
2. Customer may submit a replacement purchase order. Customer is responsible for all charges and freight associated with replacement order. Customer Service will work with production facility to have the replacement product shipped as soon as possible.
3. If "lost" equipment is delivered at a later date and is not needed, Veeder-Root will allow a Return to Stock without a restocking fee.
4. Veeder-Root will NOT be responsible for any compensation when a customer chooses their own carrier.

## **RETURN SHIPPING**

For the parts return procedure, please follow the appropriate instructions in the "General Returned Goods Policy" pages in the "Policies and Literature" section of the Veeder-Root **North American Environmental Products** price list. Veeder-Root will not accept any return product without a Return Goods Authorization (RGA) number clearly printed on the outside of the package.

©Veeder-Root 2008. All rights reserved.

**Introduction**

Related Manuals ..... 1  
Contractor Certification Requirements ..... 1  
Safety Precautions ..... 2  
Safety Warnings ..... 2

**Removing Existing Console**

**Installing the TLS-450 Console**

Mounting the Console ..... 4  
Connecting Intrinsically-Safe Wiring to the USM Module ..... 4  
Connecting Non-Intrinsically-Safe Wiring to the I/O Module ..... 4  
Connecting the Power Wires to the Console ..... 7

**Figures**

Figure 1. TLS-450 Console - Plug-in Module Compartments..... 5  
Figure 2. TLS-450 Console Dimensions and Designated Conduit Knockouts ..... 6  
Figure 3. Wiring AC Power to the TLS-450 Console ..... 8

## Introduction

This manual discusses removal of a TLS-3XX console and replacing it with a TLS-4XX console. The instructions assume all site monitoring devices have been previously installed and site wiring is complete.

### Related Manuals

---

Refer to the Tech Docs CD-ROM (V-R P/N 331650-001) for relevant information contained in the following manual:

577013-879                      TLS-4XX Series Site Prep and Installation Manual

### Contractor Certification Requirements

---

Veeder-Root requires the following minimum training certifications for contractors who will install and setup the equipment discussed in this manual:

**Installer Certification:** Contractors holding valid Installer Certification are approved to perform wiring and conduit routing, equipment mounting, probe and sensor installation, tank and line preparation, and line leak detector installation.

**TLS-350 Technician Certification:** Contractors holding valid TLS-350 Technician Certifications are approved to perform installation checkout, startup, programming and operations training, troubleshooting and servicing for all Veeder-Root TLS-300 or TLS-350 Series Tank Monitoring Systems, including Line Leak Detection and associated accessories.







**TLS-450 Technician Certification:** Contractors holding valid TLS-450 Technician Certifications are approved to perform installation checkout, startup, programming and operations training, troubleshooting and servicing for all Veeder-Root TLS-450 Series Tank Monitoring Systems, including Line Leak Detection and associated accessories.

**In-Station Diagnostics (ISD) Technician Certification:** Contractors holding valid ISD Technician Certifications are approved to perform installation checkout, startup, programming and operations training, troubleshooting and servicing for all Veeder-Root In-Station Diagnostics hardware, including ISD-PMC and Carbon Canister Vapor Polisher.

**Warranty Registrations** may only be submitted by selected Distributors.





## Safety Precautions

The following safety symbols may be used throughout this manual to alert you to important safety hazards and precautions

 <p><b>EXPLOSIVE</b> Fuels and their vapors are extremely explosive if ignited.</p>	 <p><b>FLAMMABLE</b> Fuels and their vapors are extremely flammable.</p>
 <p><b>ELECTRICITY</b> High voltage exists in, and is supplied to, the device. A potential shock hazard exists.</p>	 <p><b>TURN POWER OFF</b> Live power to a device creates a potential shock hazard. Turn Off power to the device and associated accessories when servicing the unit.</p>
 <p><b>WARNING</b> Heed the adjacent instructions to avoid damage to equipment, property, environment or personal injury.</p>	 <p><b>READ ALL RELATED MANUALS</b> Knowledge of all related procedures before you begin work is important. Read and understand all manuals thoroughly. If you do not understand a procedure, ask someone who does.</p>
 <p><b>USE SAFETY BARRICADES</b> Unauthorized people in the work area are dangerous. Always use safety cones or safety tape to block access to the work area.</p>	

## Safety Warnings

**WARNING**

   	<p><b>This console contains high voltages which can be lethal. It is also connected to low power devices that must be kept intrinsically safe.</b></p> <p><b>FAILURE TO COMPLY WITH THE FOLLOWING WARNINGS AND SAFETY PRECAUTIONS COULD CAUSE DAMAGE TO PROPERTY, ENVIRONMENT, RESULTING IN SERIOUS INJURY OR DEATH.</b></p> <ol style="list-style-type: none"> <li><b>1. Turn off and tag power at the circuit breaker. Do not connect the console AC power supply wires at the breaker until all devices are connected.</b></li> <li><b>2. Attach conduit from the power panel to the console's Power Area knockouts only.</b></li> <li><b>3. Comply with all applicable codes including: the National Electrical Code; federal, state, and local codes; and other applicable safety codes.</b></li> </ol> <p><b>Connecting power wires to a live circuit can cause electrical shock that may result in serious injury or death.</b></p> <p><b>Routing conduit for power wires into the intrinsically safe compartment can result in fire or explosion resulting in serious injury or death.</b></p>
--	--

## Removing Existing Console

The key to a successful TLS-450 retrofit installation is the careful removal of the old console and wiring.



The first concern is safety, so if you are working in a public area of the store, you want to make sure to barricade off your work area to prevent injuries.



1. Turn off and tag the breaker that supplies power to the console.
2. Remove the door screws, open the console and unplug the power connector in the power bay. It's always a good idea to use your multimeter to confirm that the circuit is dead, especially since you will be pulling these wires through the knockout.
3. Verify all probe, sensor wires are labeled before removing them so you will know to what device they are connected and their polarity if applicable. Verify all I/O wiring connections are labeled before removing them.
4. Unplug the high and low voltage connectors from the console. Remove the connectors from the high and low voltage wires. Be sure not to lose these connectors. If you plan to reinstall this console at another location you'll want to make sure to plug them back into the modules once the wires have been removed.
5. Disconnect and label all communication wires from the comm cards.
6. Remove both ground wires, the chassis ground and the barrier ground, from the grounding lugs in the console.
7. Loosen the power conduit ring, remove it and pull the wires through the knockout. Once both the high and low voltage wires have been removed, it's time to physically remove the console from the wall. Keep your screws if possible because the mounting holes for the TLS-450 will match the mounting holes for the TLS-350 that you're removing.
8. Remove the power and ground wires for the wire bundle if they were run in the same conduit with the High Voltage wires. A separate power conduit will need to be run to the TLS-450.

## Installing the TLS-450 Console

### Mounting the Console

---

The TLS-450 has the same mounting bolt pattern and approximate weight as the TLS-350 that you just removed. One major consideration for the placement of the TLS-450 is that the screen is at eye level so it can be seen and touched.

The TLS-450 doesn't have any set slots for USM (probe/sensor) and I/O (relays, pump control, etc.) modules so you can use any of the four slots to accommodate existing intrinsically safe (USM) wiring or non-intrinsically safe (I/O) wiring (see Figure 1). The key is that there is only one knockout in the top of the console and one in the bottom for each of the 4 slots (see Figure 2). Since the I/O module and the USM module can be installed in any of these 4 slots, install them where it makes the most sense for conduit connections. Remember, unless you're going to use that top knockout, you need ALL intrinsically safe wiring to come through ONE conduit.

Never use a drill to open up your knockouts. This could potentially result in metal filings getting into the console. It's much easier to just knock out the pre-punched slugs in the console anyway. Remember only knock out the smallest size you need. The console is pre-punched for 3/4" and 1" for I/O or IS wiring, but you may use up to 1-1/4" if needed but normally, this is only when direct burial cable has been used. Again, if you need to use 1 1/4" conduit, then use a punch, not a drill. Make sure that the conduit fitting ring is tight.

### Connecting Intrinsically-Safe Wiring to the USM Module

---

Try not to have too much wire in your console. Pull unneeded wire back into your wiring trough and loop it neatly. Keep in mind that you should not have your console power wiring running through this conduit.

1. Remove the connector from the USM module, loosen the screw, insert your wires and tighten well. Don't let loose wires on the connector drive you crazy when you begin the startup and probes or sensors are missing – make sure these wires are tight in the connector block. Connect all probe and sensor wires and then reconnect your block to the USM module.

Make sure that you terminate the ground shields to the ground lug on the module. As you already know, the other end at the probe or sensor is NOT grounded.

2. Write in the device name for each wire connection on the connector block in the module's wiring label attached to the inside of the door.
3. Make sure that you loop the wire neatly under the lip of the module. This will keep your wires from interfering with the door when it closes.

### Connecting Non-Intrinsically-Safe Wiring to the I/O Module

---

Try not to have too much wire in your console. Pull unneeded wire back into your wiring trough and loop it neatly.

1. Remove the connector from the I/O module, loosen the screw, insert your wires and tighten well.
2. Write in the device name for each wire connection on the connector block in the module's wiring label attached to the inside of the door.
3. Make sure that you loop the wire neatly under the lip of the module. This will keep your wires from interfering with the door when it closes.
4. Close the right door and replace and tighten the top and bottom #15 torx screws on the right side of the door.

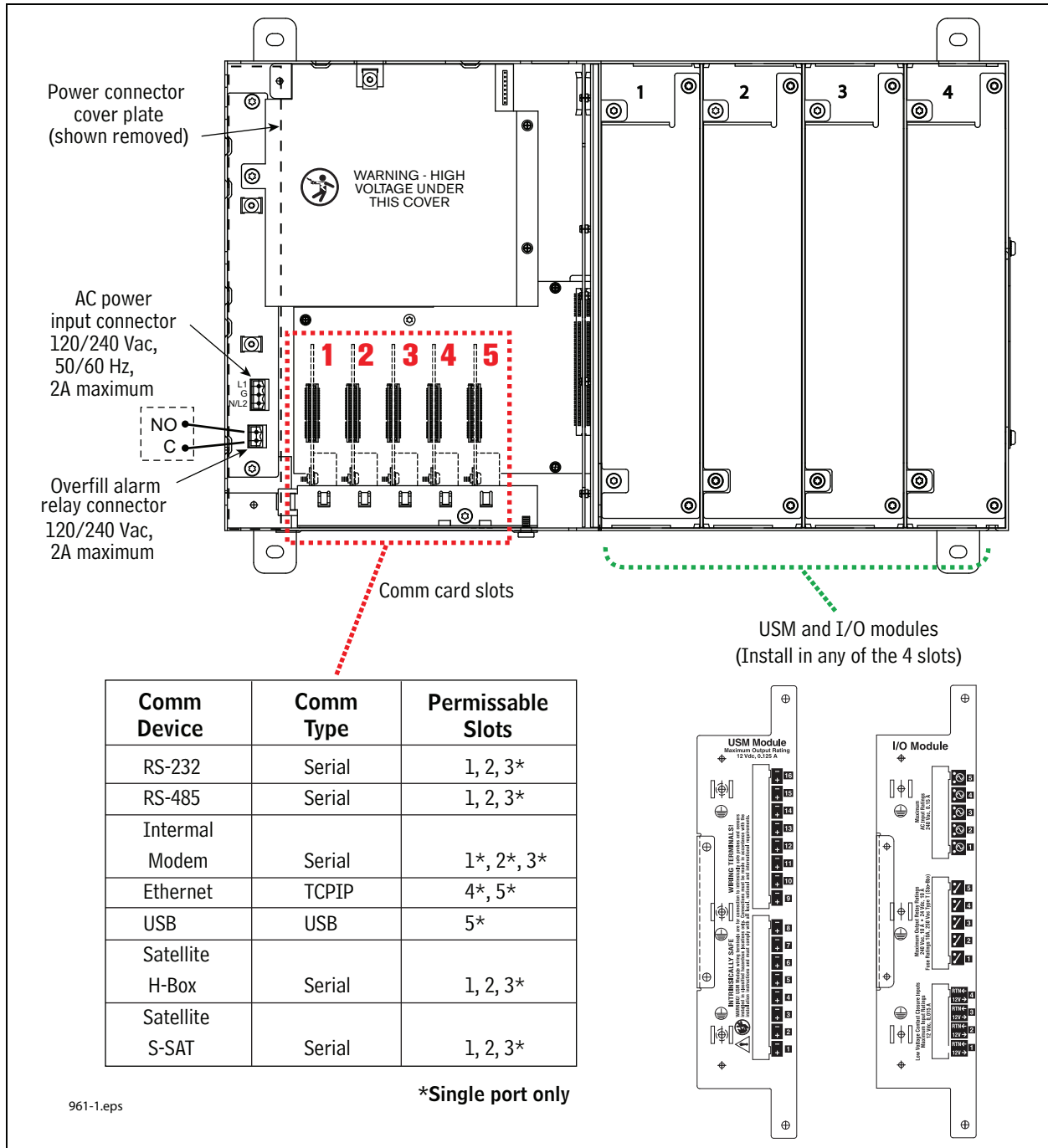

Figure 1. TLS-450 Console - Plug-in Module Compartments

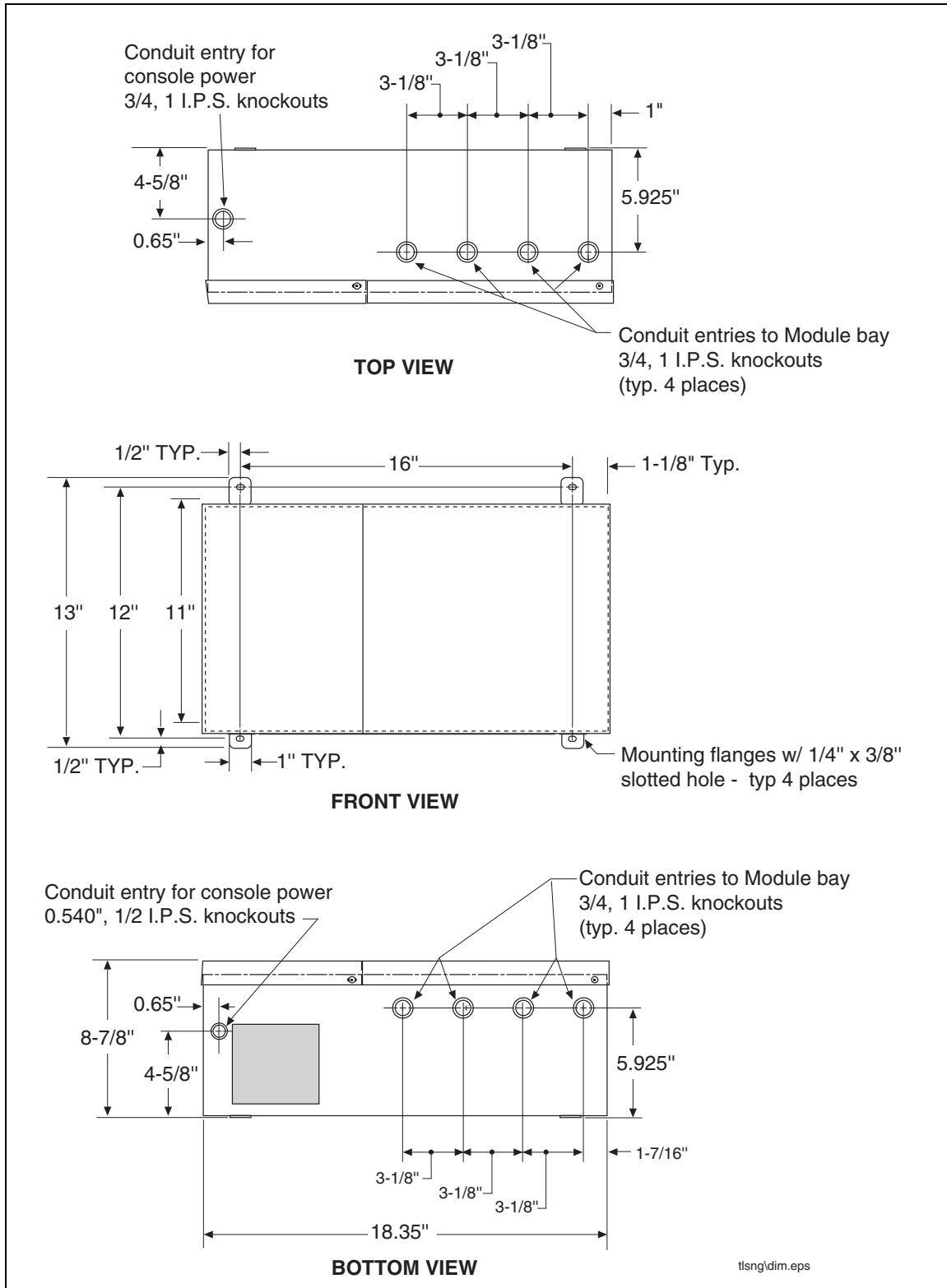

Figure 2. TLS-450 Console Dimensions and Designated Conduit Knockouts

## Connecting the Power Wires to the Console

---

Now we will conclude the TLS-450 retrofit installation by connecting power to the console.

1. With the left of the console open, remove the two screws that attach the power connector cover plate (see Figure 1).
2. Once you have removed this cover, you will see the power connector already attached to the console. This is where your panel ground, L1 and neutral (for 120 volt applications) will be used.
3. Next, remove the knockouts for console power and install the conduit from the power trough to the console. If your local code requires rigid conduit you will need to plan carefully before knocking out these holes. The console is prepunched for 1/2" conduit. This should be large enough since the only wires going through this conduit will be for the console power and possibly 1 relay. Refer to manual 577013-879 for proper wire gauge, but you will need an L1, neutral, panel ground and earth ground to be routed through this conduit and into the console.
4. We're done with the power trough now, so you can seal it up. Next strip the ends of the wires that you brought into the console. Referring to Figure 3 and to the locations printed where the power connector attaches to the console, attach the L1, panel ground and neutral wires to the connector block.
5. Next, attach the earth ground to the grounding lug as shown. Please refer to the manual 577013-879 for impedance guidelines for the earth ground.
6. Plug in the power connector and route your wires so that the cover plate will conceal them when installed.
7. Replace the power connector cover plate using both screws and close the bay door.
8. Reconnect the communication wires to the appropriate comm cards. Wires which are not used on the TLS-450 should be pulled back into the wiring trough.
9. Return to the panel, remove your lock-out/tag-out device and label the breaker with the supplied self-adhesive label. Re-energize the circuit and you are ready to start up the unit.

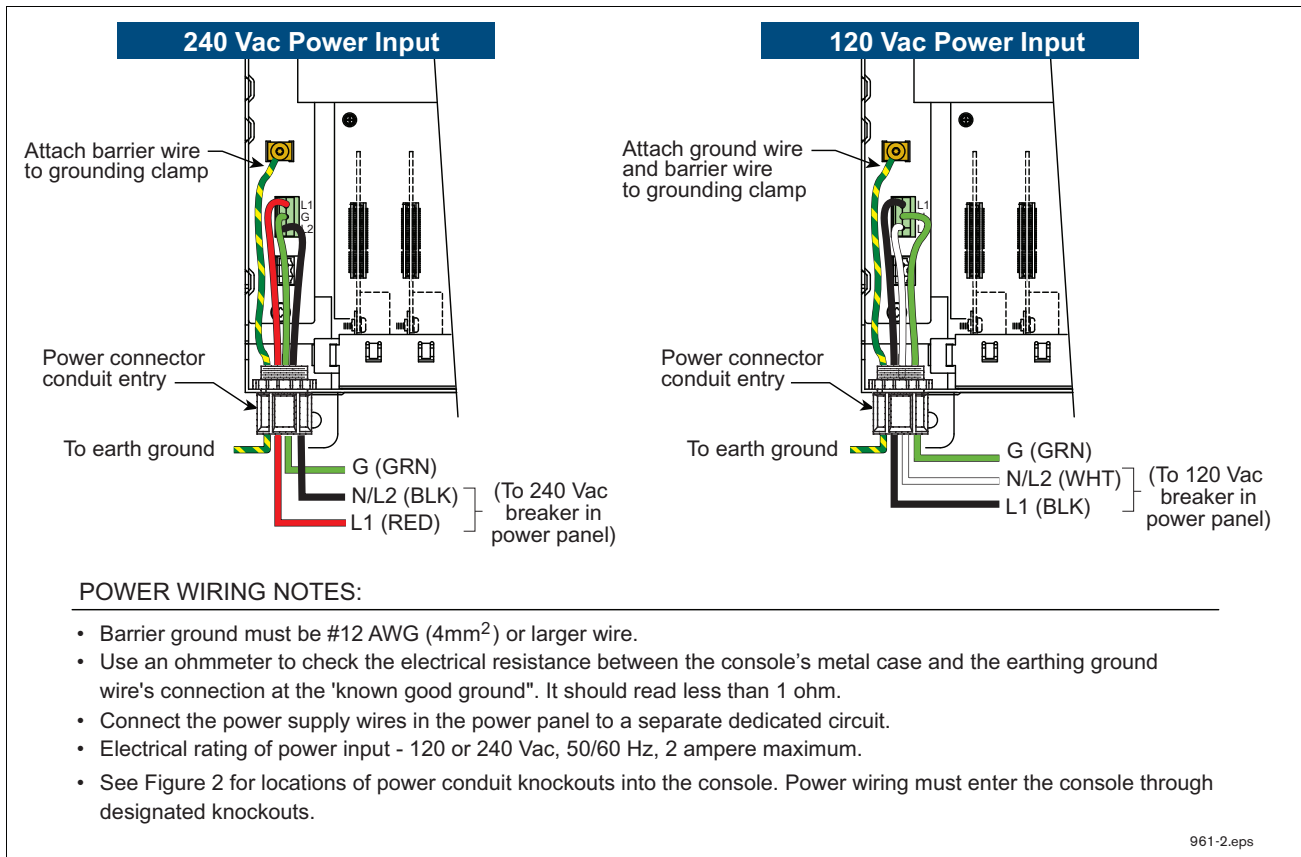

Figure 3. Wiring AC Power to the TLS-450 Console

