

**Driver Manual**  
(Supplement to the FieldServer Instruction Manual)

**FS-8705-09**  
**Rapid Engineering**  
**ICSI / ICSII**  
**(ICS one / two)**  
**Driver**

**APPLICABILITY & EFFECTIVITY**

**Effective for all systems manufactured after May 1, 2001**

## TABLE OF CONTENTS

<b>TABLE OF CONTENTS .....</b>	<b>2</b>
<b>1. ICSII Driver Description.....</b>	<b>3</b>
<b>2. Driver Scope of Supply .....</b>	<b>4</b>
2.1. Supplied by FieldServer Technologies for this driver .....	4
2.2. Provided by the Supplier of 3 <sup>rd</sup> Party Equipment .....	4
2.2.1. <i>Required 3<sup>rd</sup> Party Hardware</i> .....	4
2.2.2. <i>Required 3<sup>rd</sup> Party Software</i> .....	4
2.2.3. <i>Required 3<sup>rd</sup> Party Configuration</i> .....	4
<b>3. Hardware Connections.....</b>	<b>5</b>
3.1. Hardware Connection Tips / Hints.....	7
<b>4. Configuring the FieldServer as an ICSII Client .....</b>	<b>8</b>
4.1. Data Arrays/Descriptors.....	8
4.2. Client Side Connection Descriptions .....	9
4.3. Client Side Node Descriptors.....	10
4.4. Client Side Map Descriptors .....	11
4.4.1. <i>FieldServer Related Map Descriptor Parameters</i> .....	11
4.4.2. <i>Driver Related Map Descriptor Parameters</i> .....	11
4.4.3. <i>Timing Parameters</i> .....	12
4.4.4. <i>Map Descriptor Example 1 – Read Everything.</i> .....	13
4.4.5. <i>Map Descriptor Example 2 – Read Specific.</i> .....	14
4.4.6. <i>Map Descriptor Example 3 – Write Continuously.</i> .....	15
4.4.7. <i>Map Descriptor Example 4 – Write on Update.</i> .....	16
<b>5. Configuring the FieldServer as a (ICSII Driver) Server.....</b>	<b>19</b>
<b>Appendix 1. Advanced Topics .....</b>	<b>21</b>
<b>Appendix 2. Driver Notes.....</b>	<b>23</b>
Appendix 2.1. Map Descriptor Lengths.....	23
Appendix 2.2. ICSII Function and Data Storage Locations .....	24
Appendix 2.3. FieldServer Node Number .....	35
<b>Appendix 3. Troubleshooting tips .....</b>	<b>36</b>
Appendix 3.1. Connection Tips & Hints .....	36
Appendix 3.2. Driver Error Messages .....	36
<b>6. Revision History .....</b>	<b>40</b>

**1. ICSI and ICSII Driver Description**

This driver is used to exchange data between a FieldServer and an ICSI or ICSII HVAC controller device.

The driver is a serial driver using a RS485 serial port to connect between the FieldServer and the ICS1/2 capable device.

The driver provides client functionality.

As a client the driver can poll for data from the ICS1/2 device as well as being able to some control points and set points. Details are provided below.

Server functionality is built into the driver but is not documented or supported. This functionality is implemented to support our ongoing QC efforts.

The driver is fully compatible with other FieldServer drivers and meets FieldServer’s quality assurance standards. The driver was developed by Chipkin Automation Systems, an Approved FieldServer Integrator. Please contact Chipkin Automation System directly for support.

**Max Nodes Supported**

<b>FieldServer Mode</b>	<b>Nodes</b>	<b>Comments</b>
Client	99	Up to 99 ICS1/2 devices can be linked on one RS485 network. The functional specification of the EIA485 standard limits the number of nodes per segment to 32. If additional network segments are required then repeaters are required.

**2. Driver Scope of Supply**

**2.1. Supplied by FieldServer Technologies for this driver**

FieldServer Technologies PART #	Description
FS-8917-16	RJ-45 Pigtail for RS-485 connection
-	Driver Manual.

**2.2. Provided by the Supplier of 3<sup>rd</sup> Party Equipment**

**2.2.1. Required 3<sup>rd</sup> Party Hardware**

Part #	Description

**2.2.2. Required 3<sup>rd</sup> Party Software**

No 3<sup>rd</sup> Party software is required.

**2.2.3. Required 3<sup>rd</sup> Party Configuration**

Please contact your vendor for configuration information,

We note that at a minimum the following configuration activities must be performed.

1. Set End of Line switch
2. Connect to P6 on the ICS1/2 Board
3. Set the address on the “ADDRESSING” Switch.



### 3. Hardware Connections

The FieldServer is connected to the ICS1/2 as shown in connection drawing.

Configure the ICS1/2 according to manufacturer's instructions

**Strong Recommendation:** Protect un-isolated ports (like RS485 port on FS20 series) with an opto-isolator.

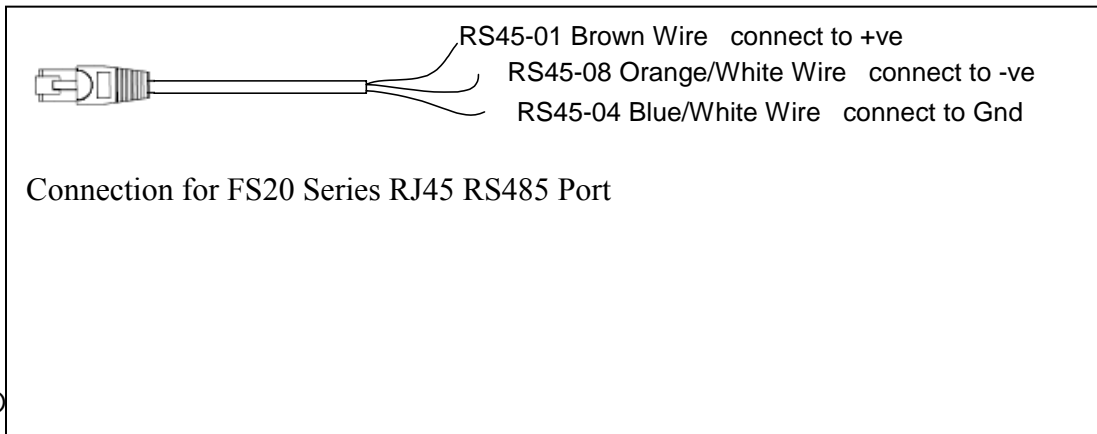
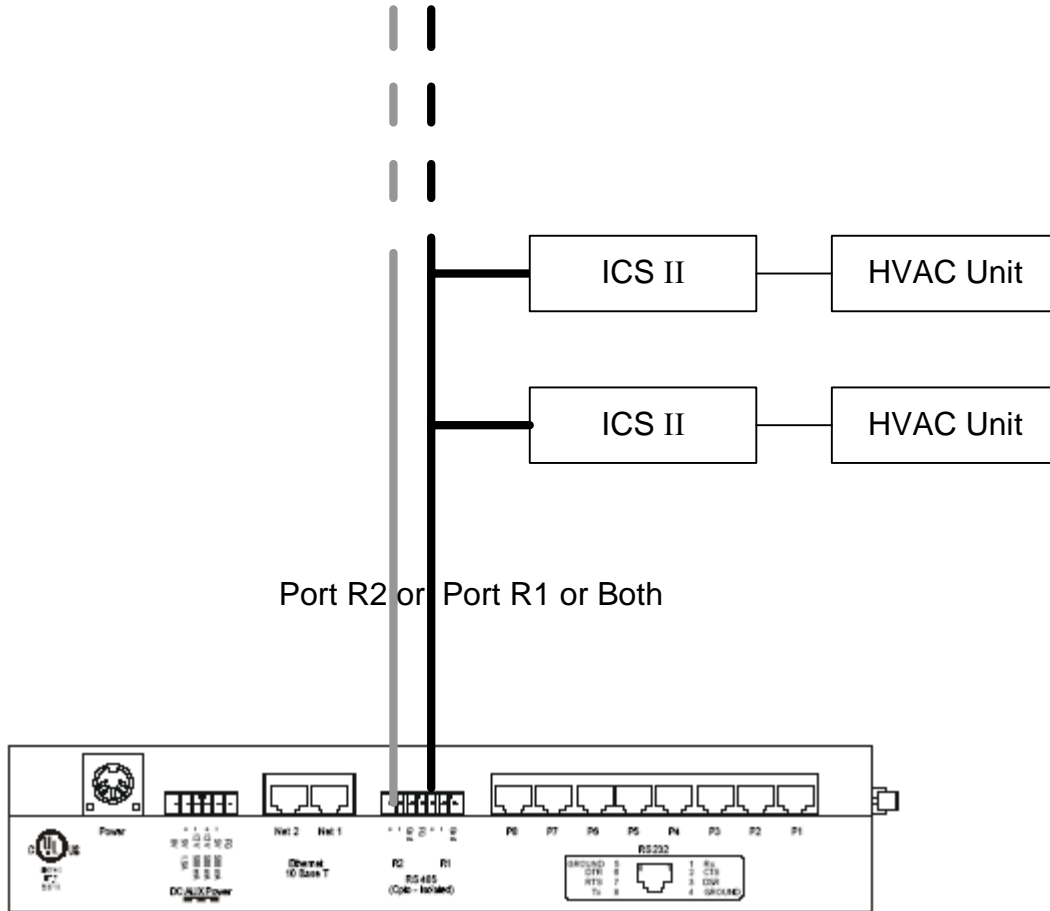

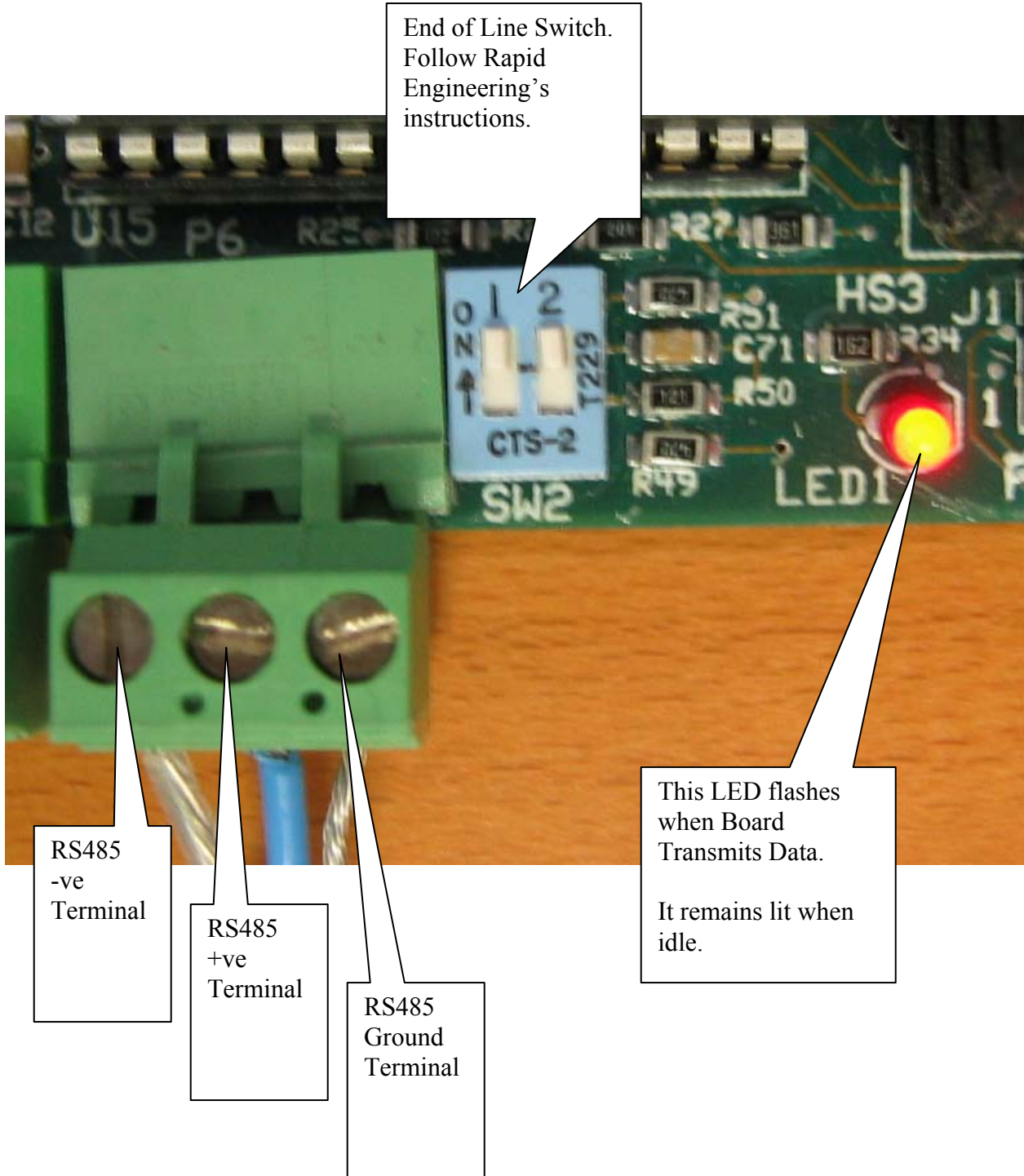

### 3.1. Hardware Connection Tips / Hints

The Red flashing LED located adjacent to connector P^ on the ICS1/2 board flashes when data is transmitted.

The green LED on the ICS1/2 board should flash periodically, This is the board health indicator,

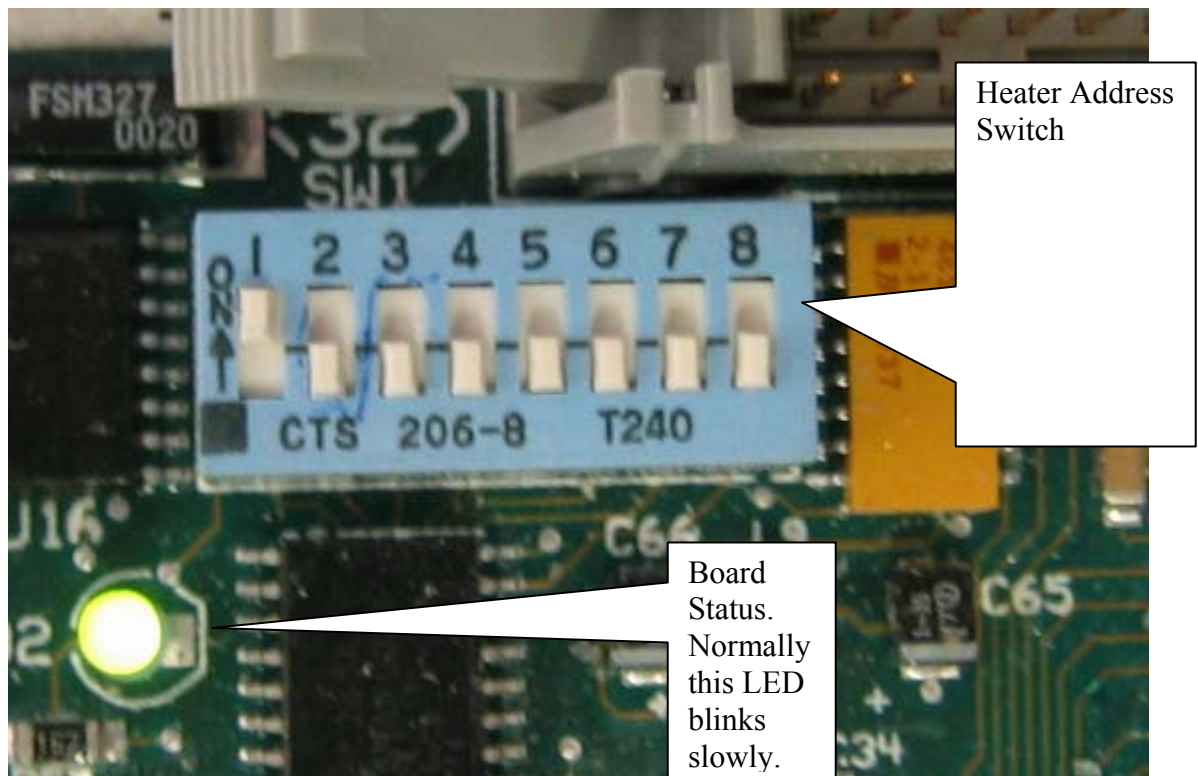

If more than one ICS1/2 boards are connected on a single network then the END of LINE switch adjacent to port P6 must be set correctly. Your vendor can provide more information on the correct settings,

#### 4. Configuring the FieldServer as an ICS1/2 Client

For a detailed discussion on FieldServer configuration, please refer to the FieldServer Configuration Manual. The information that follows describes how to expand upon the factory defaults provided in the configuration files included with the FieldServer (See “.csv” sample files provided with the FS).

This section documents and describes the parameters necessary for configuring the FieldServer to communicate with a ICS1/2 device.

##### 4.1. Data Arrays/Descriptors

The configuration file tells the FieldServer about its interfaces, and the routing of data required. In order to enable the FieldServer for (ICS1/2 Driver) communications, the driver independent FieldServer buffers need to be declared in the “Data Arrays” section, the destination device addresses need to be declared in the “Client Side Nodes” section, and the data required from the servers needs to be mapped in the “Client Side Map Descriptors” section. Details on how to do this can be found below.

Note that in the tables, \* indicates an optional parameter, with the bold legal value being the default.

Section Title		
Data_Arrays		
Column Title	Function	Legal Values
Data_Array_Name	Provide name for Data Array	Up to 15 alphanumeric characters
Data_Array_Format	Provide data format. Each Data Array can only take on one format.	Float, Bit, UInt16, SInt16, Packed_Bit, Byte, Packed_Byte, Swapped_Byte
Data_Array_Length	Number of Data Objects. Must be larger than the data storage area required by the Map Descriptors for the data being placed in this array.	1-10,000

##### Example

```
// Data Arrays
Data_Arrays
Data_Array_Name,      Data_Format,      Data_Array_Length,
DA_AI_01,             UInt16,           200
DA_AO_01,             UInt16,           200
DA_DI_01,             Bit,              200
DA_DO_01,             Bit,              200
```

4.2. Client Side Connection Descriptions

Section Title		
Connections		
Column Title	Function	Legal Values
Port	Specify which port the device is connected to the FieldServer	P1-P8, R1-R2 <sup>1</sup>
Protocol	Specify protocol used	icsii
Baud*	Specify baud rate	Driver Supports : 110; 300; 600; 1200; 2400; 4800; <b>9600</b> ; 19200; 28800; 38400; 57600; 115200 Baud Vendor Equipment support 9600 Baud
Parity*	Specify parity	Even, Odd, <b>None</b> , Mark, Space
Data_Bits*	Specify data bits	7, <b>8</b>
Stop_Bits*	Specify stop bits	<b>1</b>
Handshaking*	Specify hardware handshaking	RTS, RTS/CTS, <b>None</b>
Poll_Delay*	Time between internal polls	0-32000 seconds, <b>1 second</b>
Application*	Please read the notes in Appendix 1.1	
ICS_Firmware_version*	For ICSII controllers do not specify this parameter. For ICS1 or 310 systems you must specify this parameter and set the value to a whole number.  <b>All ICS nodes on the connection are assumed to be of the same type or have the same firmware.</b>	1 (for ICS1 or 310 Systems)
ICS_Consume_Nulls*	Specify this parameter if you think there is noise on the line. It isn't uncommon for messages from the ICS controller to be preceded or followed by a null character.  When specified and when the parameter value is set to Yes,	Yes, No

<sup>1</sup> Not all ports shown are necessarily supported by the hardware. Consult the appropriate Instruction manual for details of the ports available on specific hardware.

	the driver consumes and discards null bytes so they do not interfere with the interpretation of messages	

**Example**

```
// Client Side Connections

Connections
Port,      Protocol,      Baud,  Parity,  Handshaking,  Poll_Delay
R1,        icsii,           9600,  None,    None,         0.100s
```

**4.3. Client Side Node Descriptors**

Section Title		
Nodes		
Column Title	Function	Legal Values
Node_Name	Provide name for node	Up to 32 alphanumeric characters
Node_ID	Modbus station address of physical server node	1-99
Protocol	Specify protocol used	ICSII.
Connection	Specify which port the device is connected to the FieldServer	P1-P8, R1-R2 <sup>2</sup>

**Example**

```
// Client Side Nodes

Nodes
Node_Name      Node_ID      Protocol      Connection
PLC 1          1            ICSII         R1
```

<sup>2</sup> Not all ports shown are necessarily supported by the hardware. Consult the appropriate Instruction manual for details of the ports available on specific hardware.

**4.4. Client Side Map Descriptors**

**4.4.1. FieldServer Related Map Descriptor Parameters**

Column Title	Function	Legal Values
Map_Descriptor_Name	Name of this Map Descriptor	Up to 32 alphanumeric characters
Data_Array_Name	Name of Data Array where data is to be stored in the FieldServer	One of the Data Array names from “Data Array” section above
Data_Array_Offset	Starting location in Data Array	0 to maximum specified in “Data Array” section above
Function	Function of Client Map Descriptor	RDBC, WRBC, WRBX

**4.4.2. Driver Related Map Descriptor Parameters**

Column Title	Function	Legal Values
Node_Name	Name of Node to fetch data from	One of the node names specified in “Client Node Descriptor” above
Length	Length of Map Descriptor	1,2 ,3 etc ... See Table Appendix 2.1
Address	This commonly used parameter is not used by this driver. You can set its value to zero.	0
ICSII_Function	<p>The name of the function that must be executed when the poll is sent.</p> <p>Each ICS1/2 function reads a different set of data. Some are used to write to the ICS1/2 devices.</p> <p>If you are only interested in reading data and are happy with the driver’s default poll rates then use the simple function “Read All Reports”</p> <p>To determine what each function reads/ writes read</p>	<ul style="list-style-type: none"> <li>• Read All Reports</li> <li>• Heater Status Report</li> <li>• Setpoints Report</li> <li>• Occupied Sched Report*</li> <li>• Aux Output Sched Report</li> <li>• Setpoint Range Report</li> <li>• Error reset latch Report</li> <li>• Energy information</li> <li>• Configuration *</li> <li>• Change Mode</li> <li>• Change Setpoint</li> <li>• Change Schedule</li> </ul>

	section Appendix 2.2  Those functions marked with an * are not available on ICS1 or 310 systems.	Air Handler <ul style="list-style-type: none"> <li>• Set Aux Output Schedule*</li> <li>• Zero energy counters</li> <li>• Set Aux Output Setpoint*</li> </ul>
--	--	--

**4.4.3. Timing Parameters**

Column Title	Function	Legal Values
Scan_Interval	Rate at which data is polled	≥0.001s

4.4.4. Map Descriptor Example 1 – Read Everything.

This single Map Descriptor reads all the data that can be read from an ICS1/2 controller. One of these is required for each controller you read from. The command performs each type of read but reads the ‘Heater Report’ more often than say the ‘Configuration’ report. The driver has allocated a default frequency to each report. The relative frequency cannot be changed but the scan interval can be changed. Read Appendix 2.2 for information on where the data is stored. Please also read the notes in Appendix 1.1 which provide an outline on how to simplify the configuration.

Map_Descriptor_Name,	Data_Array_Name,	Data_Array_Offset,	Function,	ICSII_Function,	Node_name	Address	Length	Scan_Interval
ReadAll,	DA_UNIT1,	0,	RDBC,	Read All Reports,	UNIT1,	0,	345,	1.0s

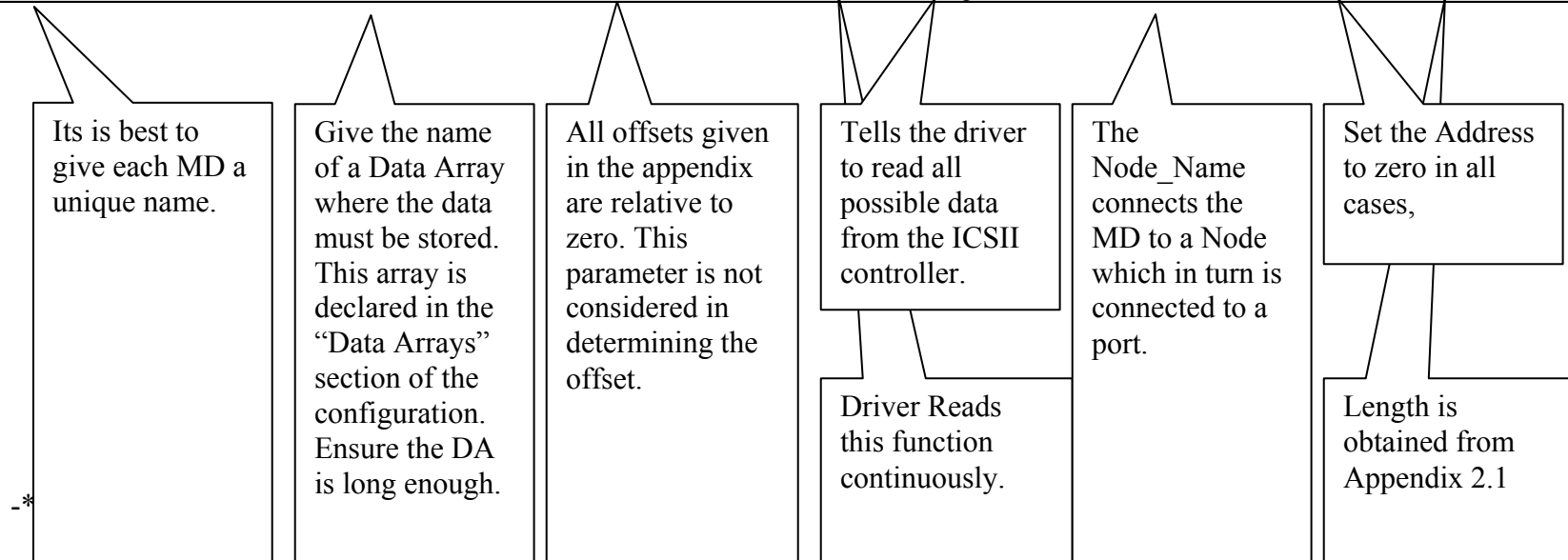

**4.4.5. Map Descriptor Example 2 – Read Specific.**

If you want to 1) Read only a specific data set and / or 2) read one set of data more frequently than done by the ‘Read All Reports’ function then add a Map Descriptor for each specific command. You can combine Map Descriptors like the ones in this example with the Map Descriptor in example 1 without a problem..

Map_Descriptor_Name,	Data_Array_Name,	Data_Array_Offset,	Function,	ICSII_Function,	Node_name	Address	Length	Scan_Interval
ReadSetpoints,	DA_UNIT1,	23,	RDBC,	Setpoints Report,	UNIT1,	0,	18,	1.0s

When Data is stored it is always done relative to offset zero. This parameter is not used in determining the storage location of data.

However, it used by the FieldServer in determining which MD owns a section of a Data Array. For this reason an offset is specified.

Suggested offsets are obtained from Appendix 2.1

In this case reads the values of Setpoints in the ICSII controller.

Set the Address to zero in all cases,

Length is obtained from Appendix 2.1

**4.4.6. Map Descriptor Example 3 – Write Continuously.**

This map descriptor changes the controller’s mode by writing the value found at offset 301 in the Data Array named “DA\_UNIT1”. The offset where the new mode number will be found was determined by inspection of the Appendix 2.2.. The value found at offset 300 is ignored when the write is done continuously.

Map_Descriptor_Name,	Data_Array_Name,	Data_Array_Offset,	Function,	ICSII_Function,	Node_name	Address	Length	Scan_Interval
SetMode,	DA_UNIT1,	300,	WRBC,	Change Mode,	UNIT1,	0,	2,	1.0s

When Data is extracted from a Data Array for a write it is always done relative to offset zero. This parameter is not used in determining the extraction location of data.

However, it used by the FieldServer in determining which MD owns a section of a Data Array. For this reason an offset is specified.

Suggested offsets are obtained from Appendix 2.1

Tells the driver to write continuously.

Tells the driver to issue the ‘Change Mode’ command.

Set the Address to zero in all cases,

Length is obtained from Appendix 2.1

**4.4.7. Map Descriptor Example 4 – Write on Update.**

This map descriptor changes the controller’s mode by writing the value found at offset 301 in the Data Array named “DA\_UNIT1”. The offset where the new mode number will be found was determined by inspection of the Appendix 2.2.

The offset on the MD has been set to 300. This is the trigger offset. The way that a write on update should work is as follows:- The remote device write the values used by the command (a single value at offset 300 for the Change Mode command) then the remote device should write a ‘1’ to the trigger offset. This will trigger the write.

Map_Descriptor_Name,	Data_Array_Name,	Data_Array_Offset,	Function,	ICSII_Function,	Node_name	Address	Length	Scan_Interval
SetMode,	DA_UNIT1,	300,	WRBX,	Change Mode,	UNIT1,	0,	1,	1.0s

When Data is extracted from a Data Array for a write it is always done relative to offset zero. This parameter is not used in determining the extraction location of data.

However, it used by the FieldServer in determining which MD owns a section of a Data Array and in the case of write on update it used by the FieldServer to determine which Data Array locations must be watched for an update.

Tells the driver to write on update. Update is not the same as change. An update occurs each time a remote device write to the offset(s) specified.

Tells the driver to issue the ‘Change Mode’ command.

Set the Address to zero in all cases,

Length is set to 1 when you write on update.

**4.4.8. Map Descriptor Example 5 – An alternate method of writing setpoints.**

Each of the 18 set points in the ICSII devices can be set. One way to achieve this to use a set of Map Descriptors like those shown below and having the upstream device set the new value in specific Data Array offsets. The driver then knows which setpoint to send to the ICSII device. The offsets and address must be exactly as specified below.

Map_Descriptor_Name,	Data_Array_Name,	Data_Array_Offset,	Function,	ICSII_Function,	Node_name	Address	Length	Setpoint_Number
Write_SP_1,	DA_UNIT1,	342,	WRBX,	Change Setpoint,	UNIT1,	342,	1,	1
Write_SP_2,	DA_UNIT1,	343,	WRBX,	Change Setpoint,	UNIT1,	343,	1,	2
Write_SP_3,	DA_UNIT1,	344,	WRBX,	Change Setpoint,	UNIT1,	344,	1,	3
Write_SP_4,	DA_UNIT1,	345,	WRBX,	Change Setpoint,	UNIT1,	345,	1,	4
Write_SP_5,	DA_UNIT1,	346,	WRBX,	Change Setpoint,	UNIT1,	346,	1,	5
Write_SP_6,	DA_UNIT1,	347,	WRBX,	Change Setpoint,	UNIT1,	347,	1,	6
Write_SP_7,	DA_UNIT1,	348,	WRBX,	Change Setpoint,	UNIT1,	348,	1,	7
Write_SP_8,	DA_UNIT1,	349,	WRBX,	Change Setpoint,	UNIT1,	349,	1,	8
Write_SP_9,	DA_UNIT1,	350,	WRBX,	Change Setpoint,	UNIT1,	350,	1,	9
Write_SP_10,	DA_UNIT1,	351,	WRBX,	Change Setpoint,	UNIT1,	351,	1,	10
Write_SP_11,	DA_UNIT1,	352,	WRBX,	Change Setpoint,	UNIT1,	352,	1,	11
Write_SP_12,	DA_UNIT1,	353,	WRBX,	Change Setpoint,	UNIT1,	353,	1,	12
Write_SP_13,	DA_UNIT1,	354,	WRBX,	Change Setpoint,	UNIT1,	354,	1,	13
Write_SP_14,	DA_UNIT1,	355,	WRBX,	Change Setpoint,	UNIT1,	355,	1,	14
Write_SP_15,	DA_UNIT1,	356,	WRBX,	Change Setpoint,	UNIT1,	356,	1,	15
Write_SP_16,	DA_UNIT1,	357,	WRBX,	Change Setpoint,	UNIT1,	357,	1,	16



## **5. Configuring the FieldServer as a (ICS1/2 Driver) Server**

A server side of the driver has been developed. It can be used to emulate an ICS1/2 device from a data (and not a functionality ) point of view. The server was developed to allow the driver to meet FieldServer's Quality Assurance efforts. It is not supported or documented, If you are interested in using the server then please contact the FST sales group.

## APPENDICES

**Appendix 1. Advanced Topics**

Application Specific Operation

This driver supports an FST technology known as Application Specific Operation. This means by using certain keywords the user can simplify the configuration effort.

**Appendix 1.1. Application = Client**

By specifying the application as Client you do not have to create any DA’s or Map Descriptors. The driver will do it for you. All that is required is a connection a node definition for each ICS1/2 device. The driver will create a single Data Array and multiple Map Descriptors to read all the data and to facilitate a write of any set point or mode.

**Example**

```
// Client Side Connections

Connections
Port,          Protocol,          Baud,          Application
R1,            icsii,              9600,          Client
```

```
// Client Side Nodes

Nodes
Node_Name      Node_ID      Protocol      Connection
HTR_01         1            ICSII         R1
```

A single Data Array called “DA\_HTR\_01” is created It is named for the node name. One DA is created for each node.

8 Map Descriptors are created. One which reads everything and 7 which can be used to write tot the device. The listing below provides details of the MDs that will be created. (If the ICS\_Firmware\_version parameter has been specified on the connection then those MD’s marked with a \* are not created.)

```
Map_Descriptors
Map_Descriptor_Name , Scan_Interval , Data_Array_Name , Data_Array_Offset , Node_Name , Function , ICSII_Function ,
Address , Length
ReadAll_Htr_01 , 0s , DA_HTR_1 , 0 , Htr_01 , Rdbc , Read Everything , 0 , 300

Map_Descriptors
```

Map_Descriptor_Name	Scan_Interval	Data_Array_Name	Data_Array_Offset	Length	Node_Name	Function	ICSII_Function
Cmd08_Htr_01	,0s	,DA_HTR_1	,300	,1	,Htr_01	, wrbx , Change Mode	,300 ,
Cmd09_Htr_01	,0s	,DA_HTR_1	,302	,1	,Htr_01	, wrbx , Change Setpoint	,302 ,
Cmd10_Htr_01	,0s	,DA_HTR_1	,305	,1	,Htr_01	, wrbx , Change Schedule Air Handler	,305 ,
Cmd20_Htr_01*	,0s	,DA_HTR_1	,313	,1	,Htr_01	, wrbx , Set Aux Output Schedule	,313 ,
Cmd11_Htr_01	,0s	,DA_HTR_1	,321	,1	,Htr_01	, wrbx , Zero energy counters	,321 ,
Cmd13_Htr_01*	,0s	,DA_HTR_1	,324	,1	,Htr_01	, wrbx , Set Aux Output Setpoint	,324 ,
Cmd07_Htr_01	,0s	,DA_HTR_1	,328	,1	,Htr_01	, wrbx , Energy information	,328 ,

## Appendix 2. Driver Notes

### Appendix 2.1. Map Descriptor Lengths

This table provides the 'Length' parameter that must be specified on a Map Descriptor's definition.

This table provides the 'Data\_Array\_Offset' parameter that must be specified on a Map Descriptors definition.

Functions marked with a \* are not supported by ICS1 or 310 systems and therefore the Data Array locations are not updated by the driver.

ICSII_Function	Length	Offset
Read All Reports	345	0
Heater Status Report	23	0
Setpoints Report	18	23
Occupied Sched Report	30	41
Aux Output Sched Report*	30	71
Setpoint Range Report	22	101
Error reset latch Report	24	123
Energy information (Read)	16	147
Configuration *	26	238
Change Mode	2	300
Change Setpoint	3	302
Change Schedule Air Handler	8	305
Set Aux Output Schedule*	8	313
Zero energy counters	3	321
Set Aux Output Setpoint*	4	324
Energy information (Write)	6	328
Set Date and Time (Broadcast to all nodes)	6	335

**Appendix 2.2. ICS1/2\_Function and Data Storage Locations**

This table does three things

- 1) Provides a list of permitted “ICSII\_Function” parameter keywords
- 2) Tells you what data each function reads / writes
- 3) Tells you where read data is stored and where written data is extracted from.

**Read Functions**

The following functions read data from the ICS1/2 and store data at the location specified in the “DA Offset” column,

Function	Parameter	Notes	DA Offset	Description
Heater Status Report	1		0	Day of Week
Heater Status Report	2		1	Date (MM)
Heater Status Report	2		2	Date (DD)
Heater Status Report	2		3	Date (YY)
Heater Status Report	3		4	Time HH
Heater Status Report	3		5	Time MM
Heater Status Report	4		6	Current Mode  0 STARTUP 1 OFF_MODE 2 AUTO 3 MANUAL 4 FLUSH_MODE 5 EXHAUST_MODE 6 AUTO_NO_PRESSRE 7 UNDERPRESSURE  The mode doesn't necessarily define the state of the burner. The change mode command would control the mode. The space temperature setpoint vs. the actual space temperature determines the on/off state of the burner.
Heater Status Report	5		7	Current State  The 'state' is simply an address location that contains a number representative of the state of the heater. This is read only. The space temperature setpoint vs. the actual space temperature determines the on/off state of the burner.

				States 1,2,3,4,5,12,14,15 the fan is on. States 3,5,12,14,15 the burner is on. State 1, relief is on.
Heater Status Report	6		8	Current space temp setpoint
Heater Status Report	7		9	Space temp
Heater Status Report	8		10	Discharge temp
Heater Status Report	9		11	Outside air temp
Heater Status Report	10		12	Pressure setpoint
Heater Status Report	11		13	Pressure
Heater Status Report	12		14	Outside air damper
Heater Status Report	13		15	Return air damper
Heater Status Report	14		16	Inputs  A single value is stored. Each bit in the value represents an input. Eg value=65520(decimal) = FFF0(hexadecimal) which is inputs 0-3 off and all others on.
Heater Status Report	15		17	Outputs
Heater Status Report	16		18	Current error
Heater Status Report	17	1	19	Space relative humidity
Heater Status Report	18	1	20	Valve position
Heater Status Report	19	1	21	Future
Heater Status Report	20	1	22	Future
Setpoints Report	1		23	Occupied temperature
Setpoints Report	2		24	Unoccupied temperature
Setpoints Report	3		25	Maximum discharge temperature
Setpoints Report	4		26	Minimum discharge temperature
Setpoints Report	5		27	Building pressure
Setpoints Report	6		28	Occupied burner turnoff
Setpoints Report	7		29	Unoccupied heater turnoff
Setpoints Report	8		30	Occupied open relief times
Setpoints Report	9		31	Unoccupied open relief times
Setpoints Report	10		32	Low temperature shutdown
Setpoints Report	11		33	Percent outside air
Setpoints Report	12		34	Burner turnoff setpoint enable//disable(1=Enable)
Setpoints Report	13		35	Outside air temp. control enable//disable(1=Enable)
Setpoints Report	14	1	36	Room relative humidity setpoint
Setpoints Report	15	1	37	Dry-bulb economizer setpoint
Setpoints Report	16	1	38	Econ type (0-1-2) none- dry-bulb-enthalpy
Setpoints Report	17	1	39	Future
Setpoints Report	18	1	40	Future

Occupied Sched Report	N/A	2	270	Period Number for most recent read Contains a numeric value 1,5,9,13,17 or 21 indicating how the following parameters should be interpreted.
			272	Set to 1 when Period number is 1,2,3,4. Else set to zero by driver
			273	Set to 1 when Period number is 5,6,7,8. Else set to zero by driver
			274	Set to 1 when Period number is 9,10,11,12. Else set to zero by driver
			275	Set to 1 when Period number is 13,14,15,16. Else set to zero by driver
			276	Set to 1 when Period number is 17,18,19,20. Else set to zero by driver
			277	Set to 1 when Period number is 21. Else set to zero by driver
Occupied Sched Report	1	2	41	Period(1-5-9-13-17)- start D
Occupied Sched Report	1	2	42	Period(1-5-9-13-17)- start HH
Occupied Sched Report	1	2	43	Period(1-5-9-13-17)- start MM
Occupied Sched Report	2	2	44	Period(1-5-9-13-17)- stop D
Occupied Sched Report	2	2	45	Period(1-5-9-13-17)- stop HH
Occupied Sched Report	2	2	46	Period(1-5-9-13-17)- stop MM
Occupied Sched Report	3	2	47	Period(2-6-10-14-18)- start D
Occupied Sched Report	3	2	48	Period(2-6-10-14-18)- start HH
Occupied Sched Report	3	2	49	Period(2-6-10-14-18)- start MM
Occupied Sched Report	4	2	50	Period(2-6-10-14-18)- stop D
Occupied Sched Report	4	2	51	Period(2-6-10-14-18)- stop HH
Occupied Sched Report	4	2	52	Period(2-6-10-14-18)- stop MM
Occupied Sched Report	5	2	53	Period(3-7-11-15-19)- start D
Occupied Sched Report	5	2	54	Period(3-7-11-15-19)- start HH
Occupied Sched Report	5	2	55	Period(3-7-11-15-19)- start MM
Occupied Sched Report	6	2	56	Period(3-7-11-15-19)- stop D
Occupied Sched Report	6	2	57	Period(3-7-11-15-19)- stop HH
Occupied Sched Report	6	2	58	Period(3-7-11-15-19)- stop MM
Occupied Sched	7	2	59	Period(4-8-12-16-20)- start D

Report				
Occupied Sched Report	7	2	60	Period(4-8-12-16-20)- start HH
Occupied Sched Report	7	2	61	Period(4-8-12-16-20)- start MM
Occupied Sched Report	8	2	62	Period(4-8-12-16-20)- stop D
Occupied Sched Report	8	2	63	Period(4-8-12-16-20)- stop HH
Occupied Sched Report	8	2	64	Period(4-8-12-16-20)- stop MM
Occupied Sched Report	9	2	65	Period(na-na-na-na-21)- start D
Occupied Sched Report	9	2	66	Period(na-na-na-na-21)- start HH
Occupied Sched Report	9	2	67	Period(na-na-na-na-21)- start MM
Occupied Sched Report	10	2	68	Period(na-na-na-na-21)- stop D
Occupied Sched Report	10	2	69	Period(na-na-na-na-21)- stop HH
Occupied Sched Report	10	2	70	Period(na-na-na-na-21)- stop MM
Aux Output Sched Report	N/A		271	Period Number for most recent read Contains a numeric value 1,5,9,13,17 or 21 indicating how the following parameters should be interpreted.
		3		
			278	Set to 1 when Period number is 1,2,3,4. Else set to zero by driver
			279	Set to 1 when Period number is 5,6,7,8. Else set to zero by driver
			280	Set to 1 when Period number is 9,10,11,12. Else set to zero by driver
			281	Set to 1 when Period number is 13,14,15,16. Else set to zero by driver
			282	Set to 1 when Period number is 17,18,19,20. Else set to zero by driver
			283	Set to 1 when Period number is 21. Else set to zero by driver
Aux Output Sched Report	1	1,3	71	Period(1-5-9-13-17 )- start D
Aux Output Sched Report	1	1,3	72	Period(1-5-9-13-17 )- start HH
Aux Output Sched Report	1	1,3	73	Period(1-5-9-13-17 )- start MM
Aux Output Sched Report	2	1,3	74	Period(1-5-9-13-17 )- stop D
Aux Output Sched Report	2	1,3	75	Period(1-5-9-13-17 )- stop HH
Aux Output Sched Report	2	1,3	76	Period(1-5-9-13-17 )- stop MM
Aux Output Sched	3	1,3	77	Period(2-6-10-14-18)- start D

Report				
Aux Output Sched Report	3	1,3	78	Period(2-6-10-14-18)- start HH
Aux Output Sched Report	3	1,3	79	Period(2-6-10-14-18)- start MM
Aux Output Sched Report	4	1,3	80	Period(2-6-10-14-18)- stop D
Aux Output Sched Report	4	1,3	81	Period(2-6-10-14-18)- stop HH
Aux Output Sched Report	4	1,3	82	Period(2-6-10-14-18)- stop MM
Aux Output Sched Report	5	1,3	83	Period(3-7-11-15-19)- start D
Aux Output Sched Report	5	1,3	84	Period(3-7-11-15-19)- start HH
Aux Output Sched Report	5	1,3	85	Period(3-7-11-15-19)- start MM
Aux Output Sched Report	6	1,3	86	Period(3-7-11-15-19)- stop D
Aux Output Sched Report	6	1,3	87	Period(3-7-11-15-19)- stop HH
Aux Output Sched Report	6	1,3	88	Period(3-7-11-15-19)- stop MM
Aux Output Sched Report	7	1,3	89	Period(4-8-12-16-20)- start D
Aux Output Sched Report	7	1,3	90	Period(4-8-12-16-20)- start HH
Aux Output Sched Report	7	1,3	91	Period(4-8-12-16-20)- start MM
Aux Output Sched Report	8	1,3	92	Period(4-8-12-16-20)- stop D
Aux Output Sched Report	8	1,3	93	Period(4-8-12-16-20)- stop HH
Aux Output Sched Report	8	1,3	94	Period(4-8-12-16-20)- stop MM
Aux Output Sched Report	9	1,3	95	Period(na-na-na-na-21)- start D
Aux Output Sched Report	9	1,3	96	Period(na-na-na-na-21)- start HH
Aux Output Sched Report	9	1,3	97	Period(na-na-na-na-21)- start MM
Aux Output Sched Report	10	1,3	98	Period(na-na-na-na-21)- stop D
Aux Output Sched Report	10	1,3	99	Period(na-na-na-na-21)- stop HH
Aux Output Sched Report	10	1,3	100	Period(na-na-na-na-21)- stop MM
Setpoint Range Report	1		101	Occupied temperature- minimum
Setpoint Range Report	2		102	Occupied temperature- maximum
Setpoint Range Report	3		103	Unoccupied temperature- minimum

Report				
Setpoint Range Report	4		104	Unoccupied temperature- maximum
Setpoint Range Report	5		105	Maximum discharge temperature- minimum
Setpoint Range Report	6		106	Maximum discharge temperature- maximum
Setpoint Range Report	7		107	Minimum discharge temperature- minimum
Setpoint Range Report	8		108	Minimum discharge temperature- maximum
Setpoint Range Report	9		109	Building pressure- minimum
Setpoint Range Report	10		110	Building pressure- maximum
Setpoint Range Report	11		111	Occupied burner turnoff- minimum
Setpoint Range Report	12		112	Occupied burner turnoff- maximum
Setpoint Range Report	13		113	Unoccupied heater turnoff- minimum
Setpoint Range Report	14		114	Unoccupied heater turnoff- maximum
Setpoint Range Report	15		115	Occupied open relief- minimum
Setpoint Range Report	16		116	Occupied open relief- maximum
Setpoint Range Report	17		117	Unoccupied open relief- minimum
Setpoint Range Report	18		118	Unoccupied open relief- maximum
Setpoint Range Report	19		119	Low temperature shutdown- minimum
Setpoint Range Report	20		120	Low temperature shutdown- maximum
Setpoint Range Report	21		121	Percent outside air- minimum
Setpoint Range Report	22		122	Percent outside air- maximum
Error reset latch Report	1		123	Error log no. 1- error no.
Error reset latch Report	2		124	Error log no. 1- error no.- Month
Error reset latch Report	2		125	Error log no. 1- error no.- Day
Error reset latch Report	2		126	Error log no. 1- error no.- Year
Error reset latch Report	3		127	Error log no. 1- error no.- Hour
Error reset latch Report	3		128	Error log no. 1- error no.- Minute

Report				
Error reset latch Report	4		129	Error log no. 2- error no.
Error reset latch Report	5		130	Error log no. 2- error no.- Month
Error reset latch Report	5		131	Error log no. 2- error no.- Day
Error reset latch Report	5		132	Error log no. 2- error no.- Year
Error reset latch Report	6		133	Error log no. 2- error no.- Hour
Error reset latch Report	6		134	Error log no. 2- error no.- Minute
Error reset latch Report	7		135	Error log no. 3- error no.
Error reset latch Report	8		136	Error log no. 3- error no.- Month
Error reset latch Report	8		137	Error log no. 3- error no.- Day
Error reset latch Report	8		138	Error log no. 3- error no.- Year
Error reset latch Report	9		139	Error log no. 3- error no.- Hour
Error reset latch Report	9		140	Error log no. 3- error no.- Minute
Error reset latch Report	10		141	Error log no. 4- error no.
Error reset latch Report	11		142	Error log no. 4- error no.- Month
Error reset latch Report	11		143	Error log no. 4- error no.- Day
Error reset latch Report	11		144	Error log no. 4- error no.- Year
Error reset latch Report	12		145	Error log no. 4- error no.- Hour
Error reset latch Report	12		146	Error log no. 4- error no.- Minute
Energy information	1		147	Last power up date MM
Energy information	1		148	Last power up date DD
Energy information	1		149	Last power up date YY
Energy information	2		150	Last power up time HH
Energy information	2		151	Last power up time MM
Energy information	3		152	Number of power ups
Energy information	4		153	Number of fan starts
Energy information	5		154	Cumulative fan hours on- thousands
Energy information	6		155	Cumulative fan hours on- 0-999
Energy information	7		156	CCF - thousands (The CCF values have no meaning unless you write meaningful values using the Write version of the Energy Information command. The reason for

				this is: To read Power Up and Start info the driver has to write the CCF limits. This is done using dummy values and therefore the CCF values in the responses cannot be used.)
Energy information	8		157	CCF - 0-999
Energy information	9		158	CCFH - low rate
Energy information	10		159	CCFH - min rate
Energy information	11		160	CCFH - max rate
Energy information	12		161	High - max rate
Energy information	13		162	High - current rate
Configuration	1	1	238	Ahu Type: AM- MUA- AR- VAV
Configuration	2	1	239	Cooling Type: Vent- Evap- DX- CW
Configuration	3	1	240	Burner Type: Gas- None- Heat Coil
Configuration	4	1	241	Software Version
Configuration	5	1	242	Exhaust(CO) Type: None- Flush Only- Exhaust Only- Both
Configuration	6	1	243	Style (ICSII as a 310- or ICSII)
Configuration	7	1	244	Rack Size(24/32)
Configuration	8	1	245	I/O configuration(12/12-24/8- etc.)
Configuration	9	1	246	Jumper Settings (16 total) 1
Configuration	9	1	247	Jumper Settings (16 total) 2
Configuration	9	1	248	Jumper Settings (16 total) 3
Configuration	9	1	249	Jumper Settings (16 total) 4
Configuration	9	1	250	Jumper Settings (16 total) 5
Configuration	9	1	251	Jumper Settings (16 total) 6
Configuration	9	1	252	Jumper Settings (16 total) 7
Configuration	9	1	253	Jumper Settings (16 total) 8
Configuration	9	1	254	Jumper Settings (16 total) 9
Configuration	9	1	255	Jumper Settings (16 total) 10
Configuration	9	1	256	Jumper Settings (16 total) 11
Configuration	9	1	257	Jumper Settings (16 total) 12
Configuration	9	1	258	Jumper Settings (16 total) 13
Configuration	9	1	259	Jumper Settings (16 total) 14
Configuration	9	1	260	Jumper Settings (16 total) 15
Configuration	9	1	261	Jumper Settings (16 total) 16
Configuration	10	1	262	Future
Configuration	11	1	263	Future
Configuration	12	1	264	Future
		2	270	Scroll up for "Occupied Sched Report"
		3	271	Scroll up for "Aux Output Sched Report"
		2	272-277	Scroll up for "Occupied Sched Report"
		3	278-283	Scroll up for "Aux Output Sched Report"

Notes

1. This data is not available for ICS1 or 310 systems.

**Write Functions**

Some commands send more than one parameter / value. If you are using the ‘wr bx’ function to write on change it is recommended that you write the parameters and then set the trigger so that when the command is sent, it is sent with a complete set of data.

Function	Param	Notes	DA Offset	Description
Change Mode	N/A		300	Change Mode Trigger
Change Mode	1		301	Mode Number
Change Setpoint	N/A		302	Change Setpoint Trigger
Change Setpoint	1		303	Setpoint Number
Change Setpoint	2		304	Setpoint Value  For Pressure, send a value that is 100x the required value.
Change Schedule Air Handler	N/A		305	Change Schedule Trigger
Change Schedule Air Handler	1		306	Period Number
Change Schedule Air Handler	2		307	Start DD
Change Schedule Air Handler	2		308	Start HH
Change Schedule Air Handler	2		309	Start MM
Change Schedule Air Handler	3		310	Stop DD
Change Schedule Air Handler	3		311	Stop HH
Change Schedule Air Handler	3		312	Stop MM
Set Aux Output Schedule	N/A	1	313	Change Schedule Trigger
Set Aux Output Schedule	1	1	314	Period Number
Set Aux Output Schedule	2	1	315	Start DD
Set Aux Output Schedule	2	1	316	Start HH
Set Aux Output Schedule	2	1	317	Start MM
Set Aux Output Schedule	3	1	318	Stop DD
Set Aux Output Schedule	3	1	319	Stop HH
Set Aux Output Schedule	3	1	320	Stop MM
Zero energy counters	N/A		321	Trigger
Zero energy counters	1		322	Fan Reset
Zero energy counters	2		323	Gas Reset

Set Aux Output Setpoint	N/A	1	324	Trigger
Set Aux Output Setpoint	1	1	325	Type
Set Aux Output Setpoint	2	1	326	Sub-Type
Set Aux Output Setpoint	3	1	327	Level
Energy information	N/A		328	Trigger
Energy information	1		329	CCFH - low rate * 100
Energy information	2		330	CCFH - min rate * 100
Energy information	3		331	CCFH - max rate * 10
Energy information	4		332	CCFH - high rate * 10
Energy information	5		333	MINVOLT - voltage value at min lin rate (8 bit 0-255)
Energy information	6		334	MAXVOLT - voltage value at max lin rate (8-bit 0-255)
Set Date and Time	N/A		335	
Set Date and Time	1		336	Month (1-12)
Set Date and Time	2		337	Day of Month (1-31)
Set Date and Time	3		338	Year (0-99)
Set Date and Time	4		339	Day of Week (1-7; 1=Sunday)
Set Date and Time	5		340	Hours (0-23)
Set Date and Time	6		341	Minutes (0-59)
Setpoint #1		4	342	1(Occupied temperature)
Setpoint #2		4	343	2(Unoccupied temperature )
Setpoint #3		4	344	3(Maximum discharge temperature)
Setpoint #4		4	345	4(Minimum discharge temperature)
Setpoint #5		4	346	5(Building pressure)
Setpoint #6		4	347	6(Occupied burner turnoff)
Setpoint #7		4	348	7(Unoccupied heater turnoff)
Setpoint #8		4	349	8(Occupied open relief times)
Setpoint #9		4	350	9(Unoccupied open relief times)
Setpoint #10		4	351	10(Low temperature shutdown)
Setpoint #11		4	352	11(Percent outside air)
Setpoint #12		4	353	12(Burner turnoff setpoint enable//disable(1=Enable))
Setpoint #13		4	354	13(Outside air temp. control enable//disable(1=Enable))
Setpoint #14		4	355	14(Room relative humidity setpoint)
Setpoint #15		4	356	15(Dry-bulb economizer setpoint)
Setpoint #16		4	357	16(Econ type (0-1-2) none- dry-bulb-enthalpy)
Setpoint #17		4	358	17(Future)
Setpoint #18		4	359	18(Future)

--	--	--	--	--

## Notes

1. This data is not available for ICS1 or 310 systems.
2. This data is multiplexed. Each time the driver reads schedule data it requests the next schedule. Check the value found at offset 270 to determine which period's data has been filled in here. You cannot directly control which period's data is read
3. This data is multiplexed. Each time the driver reads schedule data it requests the next schedule. Check the value found at offset 271 to determine which period's data has been filled in here. You cannot directly control which period's data is read
4. Upstream devices can write to these offsets to have the driver send the setpoint to the ICSii device. Map descriptors are required. See example #5 in section 4.4

### ***Appendix 2.3. FieldServer Node Number***

Every node on an ICS1/2 network must have a node number including the FieldServer. The FieldServer's node number is allocated in the configuration file. The following example shows how it is done.

It is permitted to have the same node number for the master (FieldServer) as one of the ICS1/2 controller's.

Bridge, Title, ICSII_Master,	System_Node_Id, 11
------------------------------------	-----------------------

**Appendix 3. Troubleshooting tips**

**Appendix 3.1. Connection Tips & Hints**

You could try using the ‘ICS\_Consume\_Nulls’ parameter to reduce the effects of noisy RS485 switching or a noisy line. Read 4.2 for more information.

**Appendix 3.2. Driver Error Messages**

The following message may be printed by the driver.

Many problems require that you modify the configuration file. These are marked with a ‘~’. When you have completed editing the configuration file, download the modified file to the FieldServer and reset the FieldServer for the changes to take effect.

No.	Message	Description and Corrective Action
1	ICSII:#1 Err. Bad MD length - defaulting to 1	The length of the MD must be specified. A table of length's is provided in Appendix 2.1
2	ICSII:#2 FYI. Reading Everything. MD=%s	See note ~ for corrective action. This message is informational only. You can safely ignore the message, This message is printed if the ICSII_Function in the configuration file is not recognized. Appendix 2.1 provides a list of legal function names.
3	ICSII:#3 Err. ICSII_Function invalid.	See note ~ for corrective action. If this error occurs rarely then ignore it. It results when a response cannot be interpreted correctly. It is possible that messages get corrupted occasionally.
4	ICSII:#4 Err. Take Log. Call Support. value=%d	If the error occurs repeatedly then take log and call tech Support. There is no corrective action you can take. This message is informational only. You can safely ignore the message.
5	ICSII:#5 FYI. FieldServer is Node=%d on Port=%d	The message reports the node number of the FieldServer. All nodes on a ICSII network need a node number including the FieldServer.
6	ICSII:#6a Err. Diagnostic. Call support.	The FieldServer's node number is defined in the configuration file's 'Bridge' section. Additional notes are provided in Appendix 2.3 Call tech Support. There is no

7	ICSII:#7 Err. Response Appears to come from a MASTER	corrective action you can take. If this message is printed rarely then you could assume that the message was corrupted. If it occurs often then take a log and call Tech Support. There is no corrective action you can take.
8	ICSII:#8 Err. Response Func=%d Expected=%d	If this message is printed rarely then you could assume that the message was corrupted. If it occurs often then take a log and call Tech Support. There is no corrective action you can take.
9	ICSII:#9 Err. Response From Unit#=%d Expected=%d	If this message is printed rarely then you could assume that the message was corrupted. If it occurs often then take a log and call Tech Support. There is no corrective action you can take.
10	ICSII:#10 Err. Response Func=%d. Unknown.	If this message is printed rarely then you could assume that the message was corrupted. If it occurs often then take a log and call Tech Support. There is no corrective action you can take.
11	ICSII:#11 Err. Response param count=%d Expected min=%d	If this message is printed rarely then you could assume that the message was corrupted. If it occurs often then take a log and call Tech Support. There is no corrective action you can take.
12	ICSII:#12 Err. Response param count=%d Max allowed=%d	If this message is printed rarely then you could assume that the message was corrupted. If it occurs often then take a log and call Tech Support. There is no corrective action you can take.
13	ICSII:#13 FYI. Reading Everything. This Msg=Function#%d	You can safely ignore this message. It tells you what the 'Read All Reports' function is doing at the current time. You cannot 'write through a read'. A number of other drivers support the 'write through' technology but this driver does not.
14	ICSII:#14 Err. Driver doest support write thru's. DAoffset=%d	This message will be printed when an upstream device writes to a point in a Data Array that is being read from an ICSII controller. Take steps to ensure that the upstream drivers do not do this.  To write to the ICS1/2 device, you need to explicitly create 'write' Map Descriptors as shown in examples 3 & 4.  A 'wrbx' write (wite on update) was initiated but the trigger value was not set to 1.
15	ICSII:#15a FYI. Write abandoned. Trigger not set.	This happens, if for example you set

		the length in example 4 to 2 and then had the upstream device set the value of offset 301. In this case, a write would be initiated but the trigger at offset 300 would not have been set yet.
		Configure the upstream device to write to the trigger offset too and best of all change the length's on wrbx's to 1. The specified array is too short. The required length is printed in the error.
16	ICSII:#16 Err. DA=%s too short. Rqd=%d Act=%d	Modify the configuration, adjusting the size of the Data Array. See note ~ for corrective action.
17	ICSII:#17a Err. Parse Err. Failed extracting %d params From <%s>	If this message is printed rarely then you could assume that the message was corrupted. If it occurs often then take a log and call Tech Support. There is no corrective action you can take. If this message is printed rarely then you could assume that the message was corrupted. If it occurs often then take a log and call Tech Support. There is no corrective action you can take.
18	ICSII:#18 Err. Response param length=%d Max allowed=%d	If this message is printed rarely then you could assume that the message was corrupted. If it occurs often then take a log and call Tech Support. There is no corrective action you can take. The specified array is too short. The required length is printed in the error.
19	ICSII:#19 Err. DA=%s Too small. Rqd Len=%d	Modify the configuration, adjusting the size of the Data Array. See note ~ for corrective action.
20	ICSII:#20a Err. Parameters could not be extracted. ret=%d	If this message is printed rarely then you could assume that the message was corrupted. If it occurs often then take a log and call Tech Support. There is no corrective action you can take.
21 22	ICSII:#21 Err. ret=%d Func=%d buf=%s buf+8=%s	If this message is printed rarely then you could assume that the message was corrupted. If it occurs often then take a log and call Tech Support. There is no corrective action you can take.
		The specified array is too short. The required length is printed in the error.
23 24 25	ICSII:#23 Err. DA=%s too short. Min Length=%d.	Modify the configuration, adjusting the size of the Data Array. See note ~ for corrective action.
		The specified array is too short. The required length is printed in the error.
26	ICSII:#26 Err. DA=%s too short. Rqd=%d Act=%d	Modify the configuration, adjusting the

		size of the Data Array. See note ~ for corrective action. This message is printed when the configuration specifies Application Specific Operation with "Client" as the parameter. Appendix 1.1 provides additional information.
27	ICSII:#27 FYI. ASO Operation. Client Only.	No corrective action is required. This message should never be printed as this mode is not supported. Read Appendix 1.1 and modify your configuration file if necessary. If you cannot eliminate this message then call tech Support.
28	ICSII:#28 FYI. ASO Operation. Client & Server.	This message is printed when the driver create Map Descriptors and Data Arrays as part of the Application Specific Operation (ASO). If the message is printed then not all the MD's will be created and the ASO will not operate correctly.  If this message is printed please review the notes in Appendix 1.1 and if necessary call Tech Support.
29	ICSII:#29 Err. Heading not equal to keywords	Is you are using Application Specific Operation (ASO) then it is essential that this message gets printed in the error log. It provides confirmation that the Data Arrays and Map Descriptors required for ASO have been created.
30	ICSII:#30 FYI. ASO Operation. DA's and MD's created.	No corrective action is required when this message is printed. The ICS server requires a Data Array to store the time sent by a broadcast from the master.
31	ICSII:#31 Err. No Date/Time DA.	Modify the config to create a Data Array called 'ICS_DATE_TIME' with a length of at least 6. Once modified, download the config to the FieldServer and reset the FieldServer for the changes to take effect.
32	ICSII:#32 Err. Cant unpack date time info.	The message is corrupt and the broadcast date and time message cant be used to update a Data Array. There is no corrective action you can take.

6. Revision History

Date	Resp	Format	Driver Ver.	Doc. Rev.	Comment
6/18/04	PMC	PMC	1.00a	0	Document Created
9/23/04	PMC	PMC	1.00c	0	<p>Section 4.2 _ Notes on new connection parameters 'ICS_Consume_Nulls' and 'ICS_Firmware_version'</p> <p>Appendix 1.1 Notes on how Map Descriptor auto creation is affected by the parameter 'ICS_Firmware_version'</p> <p>Appendix 2.1 Notes on which functions are supported for ICS1 and 310 systems</p> <p>Appendix 2.2 Notes on which Data Array locations are supported for ICSII, ICS1 and 310 systems</p>
12/17/04	PMC	PMC	1.00d	0	<p>Appendix 2.2 Schedule Data: Notes explain how this data is multiplexed. The period numbers for the most recent read are stored at offsets 270, 271. The driver automatically reads successive period data.</p> <p>Appendix 2.2 Added info on broadcasting the date and time to all the ICS units.</p> <p>Appendix 2.2 Added notes on how energy information is written.</p> <p>Appendix 2.2 Added notes on how energy information is read.</p> <p>Appendix 2.2 Added notes on how to interpret the current state reported at offset 7</p> <p>Appendix 3.2 Added Msgs.</p>
1/21/05	PMC	PMC	1.00f	0	Appendix 2.2 Schedule Data: Notes explain

					how this data is multiplexed. The period numbers for the most recent read are stored at offsets 270, 271. but in addition the driver sets one of the following offstes non-zero and the others zero to indicate the period – 272,273,274,275,276,277 (for Schedule data) and 278,279,280,281,282,283 ( for aux sched data) .
3/21/05	PMC	PMC	1.00h	0	New method of writing setpoints.
1/5/07	PMC	PMC	1.00i	0	New connection info.
9/30/08	PMC	PMC	All		Corrected notes on mode and state. Previously reported that state2 burner was on and 3 was off.
2009Mar31	PMC	PMC	All	0	Offsets 336 and 337 were transposed.
2009Aug26	PMC	PMC	All	0	When setting date and time. Day of Week: 1=Sunday.